

1800 CC 4 CYLINDER

GENERAL SPECIFICATIONS										
Year	Displ.		Carburetor	HP at RPM ^①	Torque (Ft. Lbs. at RPM) ^①	Compr. Ratio	Bore		Stroke	
	cu. ins.	cc					in.	mm	in.	mm
1976	107.13	1756	2-Bbl	86@6200	90@2800	8.0-1	3.31	84	3.12	79.2

① — Models with catalytic converters — 83 HP at 5800 RPM; 89 Ft. Lbs. at 3200 PM.

ENGINE IDENTIFICATION

Engine number is stamped on cylinder block. Further identification data is found below windshield inside engine compartment, on upper left hand side of instrument panel by windshield, and inside door closing areas.

Engine Identification Numbers^①

Body Style	Chassis No.	Engine No.
Beta Sedan	828 CB.6	828 A1.040.6
Beta HPE	828 AF.1	828 A1.040.6
Beta Coupe	828 AC.1	828 A1.040.6

① — Engines equipped with catalytic converters are numbered 828 A1.031.6.

ENGINE REMOVAL

1) Remove the alternator and slacken front wheel retaining bolts. Raise vehicle and drain coolant from engine and radiator. Take off front wheels and splash guards. Remove all flexible hoses from carburetor and electrical lead from slow-running cut-out switch.

2) Remove low pressure hose for servo-brake, fast idling and diverter valve from induction manifold. Disconnect leads from the distributor and diverter valve thermo-switches.

3) On vehicles with air conditioning, slacken mounting bolts and drop compressor downward. Remove drive belt. Disconnect electric cables from the isobaric valve and compressor ground cable. Remove compressor and position it on its side so oil does not enter conditioner circuit. Remove leads from thermistor and engine oil pressure switch and take off oil filter base.

4) Lift out battery. Remove line from recovery tank, and remove tank. Slide line from diverter valve and disconnect drive belt from air pump. Remove air pump complete with support and line. Detach pipe from air pipe leading to exhaust ducts on the cylinder head. Remove distributor assembly.

5) Unscrew the constant velocity joints from their flanges by the wheel well. Take off support brackets and disconnect the exhaust pipe from the manifold. Remove flywheel guard and bolts holding transmission and engine mounts. Remove the gear front control shaft from the idler lever and selector rod.

6) Detach heater hoses from cylinder head and water pump inlet hose. Remove hoses from radiator. Remove speedometer drive shaft from transmission and cables from 1st and 2nd gear switch, 3rd and 4th gear switch and 5th gear commutator switch. Mark electrical connections for later installation.

7) Disconnect ground wire from transmission and leads from starter motor. Remove clutch release lever return spring. Release the control cable from the clutch release lever and slip the cable sheath from stop bracket.

8) Remove circlip and detach the release lever from the shaft. Remove clutch stop bracket. Remove engine-to-body anchoring rod. Disconnect fan leads and remove the fan from the radiator. Mount brackets (88017363) on cylinder block stud bolts for use in hoisting engine and transmission from vehicle.

9) Mount a hoist above vehicle and attach hook (88017362). Raise engine and transmission and remove from vehicle. Set on support stand (88017364) and attach support (88027068A) to transmission. Remove starter motor and transmission from engine. Lock the crankshaft with locking tool (88013347), and remove the clutch assembly.

10) To install engine, reverse removal procedure. Be sure to tighten constant velocity flange bolts to proper torque. Start engine and check for leaks.

CYLINDER HEAD REMOVAL

1) Disconnect positive battery cable. Drain coolant from radiator and engine. Remove exhaust pipe from manifold. Remove right-hand brace from engine compartment opening and take off air cleaner. Disconnect choke control cable and fuel supply and leak-off hoses from carburetor.

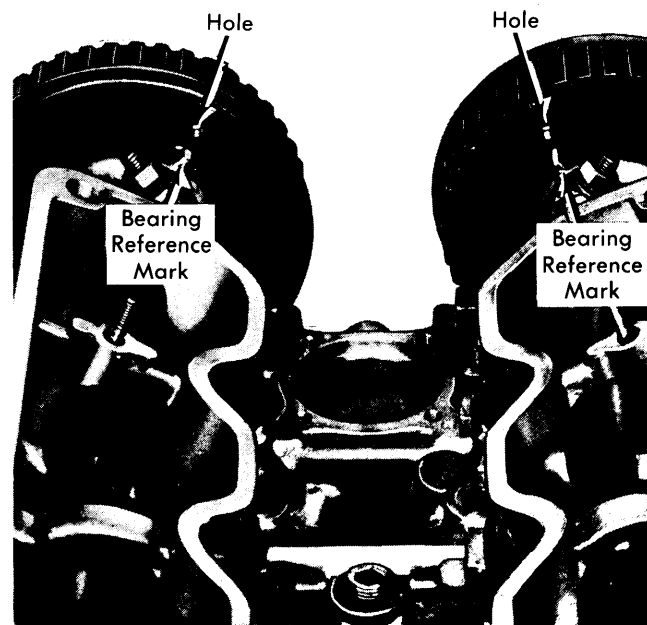

Fig. 1 Camshaft Bearing and Gear Timing Marks

Lancia Engines

1800 CC 4 CYLINDER (Cont.)

2) Disconnect brake servo unit vacuum hose from intake manifold. Disconnect cables from spark plugs, coolant temperature gauge transmitter and engine overheating warning light switch. Disconnect throttle control rod from carburetor and set it aside. Remove splash guard from right hand wheel well. Remove timing gear cover.

3) Using a spanner wrench (88011321) on crankshaft nut, turn crankshaft in direction of rotation until the camshaft bearing timing marks (See Fig. 1) line up with holes in camshaft drive gears. Remove the timing reference pointers fitted bracket. Disconnect coolant outlet pipe from both the cylinder head and rubber hoses.

4) Remove engine-to-body anchoring rod. Lift off engine coolant outlet and inlet pipes. Disconnect heater hose with mounting bracket from cylinder head. Remove alternator upper mounting link.

5) Loosen timing belt stretcher and remove timing belt from gears and stretcher. Remove bolts and lift off cylinder head complete with manifolds.

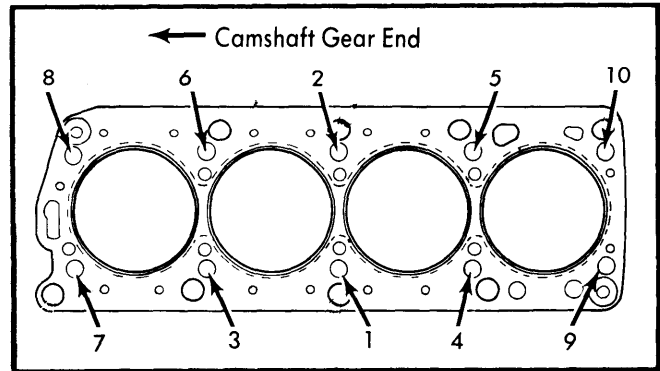

Fig. 2 Cylinder Head Bolt Tightening Sequence

6) To install cylinder heads, reverse removal procedure, noting the following: Clean block and head mating surfaces. Install new head gasket to block. Tighten cylinder head bolts to a final torque of 61.5 ft. lbs. (8.5 mkg) in proper sequence and in two stages. See Fig. 2. Refit timing belt and set valve timing. Check valve clearance and install remaining parts in reverse order.

VALVES							
Engine & Valve	Head Diam. In. (mm)	Face Angle	Seat Angle	Seat Width In. (mm)	Stem Diameter In. (mm)	Stem Clearance In. (mm)	Valve Lift In. (mm)
1800 cc Intake	1.622-1.638 (41.2-41.6)	45°	45°	.083 (2.1)	.314-.315 (7.974-7.992)	.001-.003 (.030-.066)
Exhaust	1.411-.435 (35.85-36.45)	45°	45°	.067 (1.7)	.314-.315 (7.974-7.992)	.001-.003 (.030-.066)

VALVE ARRANGEMENT

Intake — Left side (Viewed from flywheel end).
Exhaust — Right side (Viewed from flywheel end).

2) Test springs for proper strength, using a suitable tester (88095021).

VALVE GUIDE SERVICING

1) Visually check inner diameter of valve guides for scoring or signs of seizure. Use gauges (88015018 and 88015019) to measure valve guide bores.

2) If guides need servicing, remove guide seals. Using a remover-installer tool (88012042), remove guides from cylinder head. Check guides to determine class, by measuring external diameter. New valve guides should belong to same class as those removed.

VALVE SPRINGS			
Engine	Free Length In. (mm)	PRESSURE Lbs. @ In. (kg @ mm)	
		Valve Closed	Valve Open
1800 cc Inner	1.666 (42.32)	31.7-34.0@1.22 (14.4-15.4@31)	59.3-64.6@.85 (269-29.3@21.5)
Outer	2.122 (53.9)	82.5-89.1@1.42 (37.4-40.4@36)	125.7-136.7@1.02 (57-62@26)

VALVE SPRINGS

1) Remove cylinder head. Remove both intake and exhaust manifolds and carburetor. Use spring compressor (88012041) to load valve springs. Remove split collets and remove upper collars, inner and outer springs, lower cups and washers.

Available Valve Guide Diameters

Measurement	Inches (mm)
Standard Guide O.D.	.590-.591 (14.998-15.016)
1st Oversize Guide O.D.	.591-.592 (15.018-15.036)
2nd Oversize Guide O.D.	.598-.599 (15.198-15.216)

1800 CC 4 CYLINDER (Cont.)

3) Heat cylinder head (manufacturer recommends in an electric furnace) to 212° F (100° C). Install the new guides using the installer tool (88012042) and spacer (88012042B).

NOTE — Replacement valve guides feature an inner diameter bored to specifications. Reaming may be necessary, however, in isolated cases.

4) After the cylinder head has cooled, check inner diameter and if necessary ream to proper size. With guides fitted in cylinder head, inner diameter should measure .3158-.3165" (8.022-8.040 mm). Use gauge 88015018 to check for inner diameter of .3153-.3157" (8.01-8.02 mm) and 88015019 to check for inner diameter of .3161-.3165" (8.03-8.04 mm).

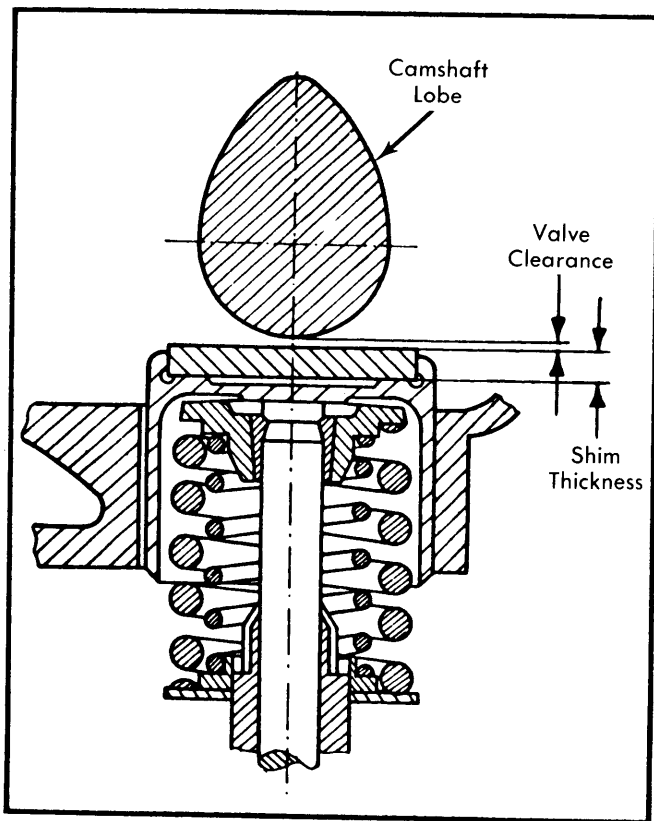

Fig. 3 Measuring Valve Clearance

VALVE CLEARANCE ADJUSTMENT

1) The Lancia 1800 cc engine has two camshafts, one operating directly upon the exhaust valves, the other on the intake valves. No rocker arms or shafts are necessary.

2) Check valve clearance in order of firing sequence (1-3-4-2). Using a spanner wrench (88011321), turn crankshaft so that cylinder to be checked is in the expansion stroke (cam lobe pointing vertically for that cylinder). See Fig. 3.

3) Measure clearance of each valve, using a feeler gauge between the base of the cam lobe and the tappet shim. Make a note of each valve's clearance.

Valve Clearance Specifications

Valve	Inches (mm)
Intake0161-.0193 (.41-.49)
Exhaust0181-.0213 (.46-.54)

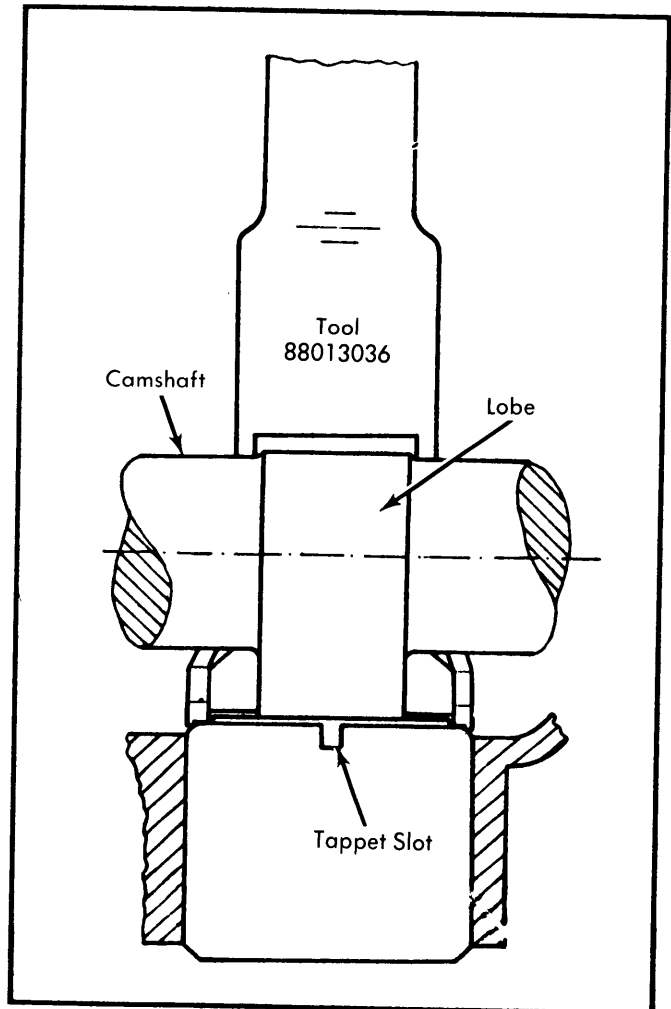

Fig. 4 Adjusting Valve Clearance

4) To adjust valves, turn crankshaft until piston of cylinder to be adjusted is in expansion stroke (cam lobe vertical). Turn tappets so slot (See Fig. 4) is toward side of engine. Turn crankshaft further so that valve to be adjusted is fully open. Attach suitable tool (88013036) between camshaft and tappet and secure against housing.

5) Turn the crankshaft (turning camshafts) until camshaft lobe does not depress the tappet any longer, while the tool keeps the tappet locked in the open valve position. Apply air pressure to tappet slot, and remove the adjusting shim (See Fig. 5) using pliers (88013038).

6) Measure the thickness of the adjusting shim removed. Add the previously measured valve clearance for valve being adjusted. Subtract from this total the recommended valve

Lancia Engines

1800 CC 4 CYLINDER (Cont.)

clearance. Replace the previously removed adjusting shim with one having the thickness of the difference obtained by your subtraction.

Example:

Measured intake valve clearance = .015" (0.38 mm)
 Add measured shim thickness = .142" (3.60 mm)

Total of shim thickness and clearance = .157" (3.98 mm)
 Subtract recommended clearance = .017" (0.43 mm)

Difference is required shim thickness ① = .140" (3.55 mm)

① — Shims for adjusting valve clearance are available in thicknesses ranging from .1280-.1850" (3.25-4.70 mm) in .0020" (.05 mm) increments. Thickness of shim is stamped on its face, and stamped side must be installed facing downward. To be on safe side, always check shim thickness with a micrometer before installing it.

7) Fit the shim in place, using pliers (88013038). Turn crankshaft until camshaft fully depresses the tappet. Remove

tool (88013036). When all valves have been set, recheck for proper clearance and reinstall parts previously removed.

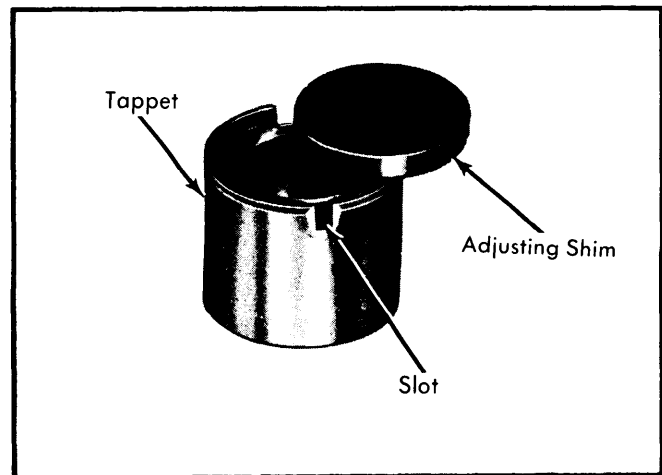

Fig. 5 Removing Adjusting Shims From Tappets

PISTONS, PINS, RINGS						
Engine	PISTONS	PINS		RINGS		
	Clearance In. (mm)	Piston Fit In. (mm)	Rod Fit In. (mm)	Rings	End Gap In. (mm)	Side Clearance In. (mm)
1800 cc	.0157-.0236 (.40-.60)	.0001-.0003 (.002-.008)	.0004-.0006 (.010-.016)	No. 1	.012-.018 (.30-.45)	0018-.0030 (.045-.077)
				No. 2	.008-.014 (.20-.35)	.0012-.0028 (.030-.070)
				No. 3 (Oil)	.008-.014 (.20-.35)	.0012-.0024 (.030-.062)

OIL PAN

1) Remove bracket securing exhaust pipe to engine block. Remove right-hand constant velocity joint from drive flange and set drive shaft aside. Remove exhaust pipe from manifold. Take off flywheel guard and remove bolts from right-hand engine mount. Loosen left-hand engine mount.

2) Remove the gear control selector rod from the front control shaft. Drain coolant and oil from engine. Disconnect speedometer drive cable, and remove gear front control shaft from idler lever. Disconnect speedometer drive cable from EGR valve. Remove battery cables and lift out battery.

3) Remove ignition coil and hose clip. Remove clutch control cable support bracket. Disconnect inlet hose from the radiator. Detach anchoring rod from cylinder head and frame. Remove heater hose support bracket from exhaust camshaft housing and remove air cleaner assembly.

4) Remove engine compartment opening right-hand brace. Turn front wheels to full right and remove splash guard from right-hand wheel well. Disconnect outlet hoses from radiator.

5) Attach lifting cable (88017362) to engine and using a hoist, lift engine slowly upward only enough to permit oil pan bolt removal. Then, lift engine further until oil pan can be removed. To install, reverse removal procedures.

PISTON & ROD ASSEMBLY

1) Place engine on stand, remove timing belt, cylinder head and oil pan. Remove oil pump from crankcase. Turn ancillary units drive shaft until the fuel pump control cam points towards the fuel pump itself. Remove connecting rod caps and slide pistons and rods out top of block as an assembly. Inspect connecting rods, bearing shells and crankshaft surfaces for scoring and wear. Check that crankpin surfaces do not show signs of scoring or seizure.

2) Always keep connecting rods and caps together so that they are not interchanged before or during assembly. To install piston and rod assemblies, turn flywheel so crankpins of No. 1 and No. 4 cylinders are at bottom dead center. Stagger piston rings at 120° intervals (gaps not aligned). Lubricate pistons for No. 1 and No. 4 cylinders and slide them part way into bores.

3) Use a ring compressor (88013200) to complete installation of pistons, pushing lubricated connecting rod bearings down onto crankpins.

NOTE — The numbers stamped on the connecting rod side must face the side of the engine block opposite from the fuel pump.

1800 CC 4 CYLINDER (Cont.)

4) Using Plastigage method, check clearance between crankpins and bearing shells. To do so, remove oil marks from connecting rod bearing shell. Place a piece of Plastigage lengthwise on crankpin at center of connecting rod cap bearing shell. Lightly grease ends of string to stick it to crankpin.

5) Attach connecting rod cap with bearing shell and torque to 38 ft. lbs. (5.2 mkg). **NOTE** — Be sure you do not turn crankshaft in process, or Plastigage may be damaged and give incorrect reading. Remove connecting rod cap and measure width of the flattened Plastigage at its widest point. Use scale stamped on envelope for reading clearance between connecting rod bearing shells and crankpin. Clearance should match specifications.

6) Remove Plastigage from crankpins and lubricate and fit caps of No. 1 and No. 4 connecting rods. Tighten to proper torque. Install piston and rod assemblies in cylinders No. 2 and No. 3 and check for clearance in same manner. When proper, torque connecting rod cap nuts. Reinstall oil pump, oil pan, oil filter base and other parts previously removed.

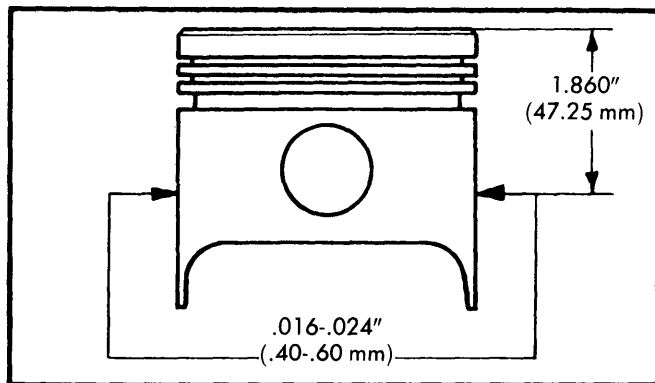

Fig. 6 Measuring Piston Diameter

FITTING PISTONS

1) Visually inspect pistons for signs of seizure or scoring. Remove rings and set aside in proper location for later installation (if not to be replaced). Measure outside diameter of pistons at a point 1.86" (47.25 mm) below piston crown and at right angles with piston pin bore. See Fig. 6.

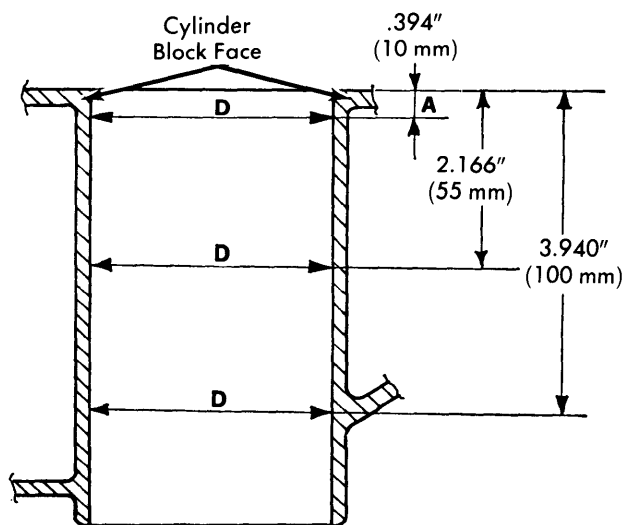

Fig. 7 Measuring Cylinder Bore Diameters

2) Measure cylinder diameters at points .394" (10 mm), 2.166" (55 mm), and 3.94" (100 mm) below surface of block and parallel and at right angles to crankshaft. See Fig. 7.

3) Subtract the diameter of each piston from the diameter of its cylinder. Clearance should be .0157-.0236" (.40-.60 mm). Pistons, piston pins and bores vary by class as to size. Class identification numbers and letters for pistons and pins are found inside the piston on piston pin bore casting (underneath side of piston). See Fig. 8. Cylinder blocks are also stamped as to cylinder bore class.

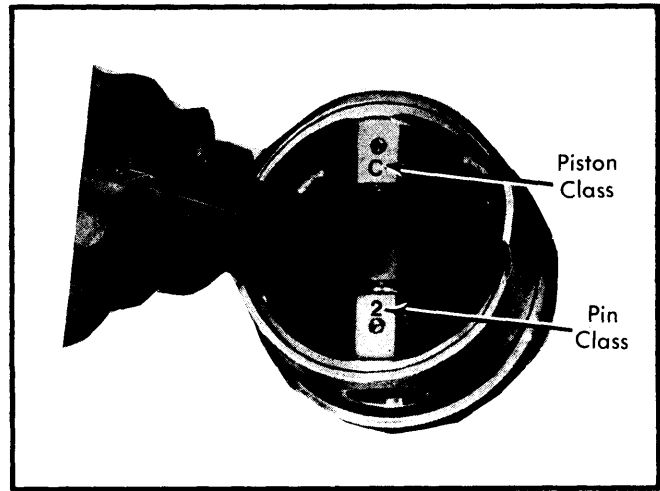

Fig. 8 Identifying Marks for Piston & Pin Classes

Piston Sizes Available[Ⓛ]

Class	Inches (mm)
Class A	3.3051-3.3055 (83.95-83.96)
Class B	3.3055-3.3059 (83.96-83.97)
Class C	3.3059-3.3063 (83.97-83.98)
Class D	3.3063-3.3067 (83.98-83.99)
Class E	3.3067-3.3070 (83.99-84.00)

[Ⓛ] — Standard pistons for Classes A, C, and E and pistons and rings .0078" (.2 mm), .0157" (.4 mm), and .0235" (.6 mm) oversize are furnished for repairs.

Cylinder Bore Classes

Class	Inches (mm)
Class A	3.3070-3.3074 (84.00-84.01)
Class B	3.3074-3.3079 (84.01-84.02)
Class C	3.3079-3.3083 (84.02-84.03)
Class D	3.3083-3.3087 (84.03-84.04)
Class E	3.3087-3.3091 (84.04-84.05)

Piston Pin Sizes[Ⓛ]

Class	Inches (mm)
Class 1	.8658-.8659 (21.991-21.994)
Class 2	.8659-.8660 (21.994-21.997)

[Ⓛ] — Piston pin bore sizes for each class pin should be .0002" (.005 mm) larger than above pin sizes.

Lancia Engines

1800 CC 4 CYLINDER (Cont.)

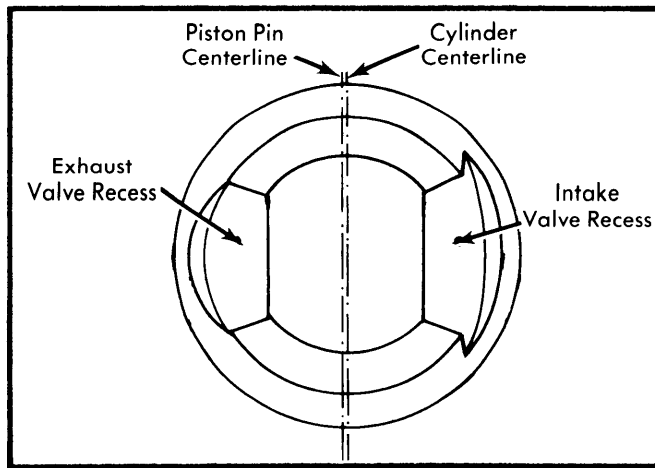

Fig. 9 Piston Crown Viewed From Top

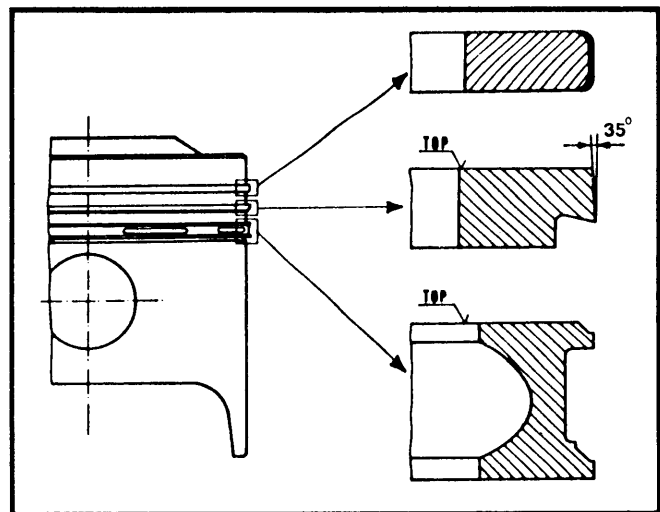

Fig. 10 Installing Rings on Pistons

4) When installing pistons on connecting rods, be sure the intake valve recess (See Fig. 9) in the piston crown is on the side of the connecting rod with the lubrication hole. Use suitable tool (88012211) to install circlips securing piston pins.

5) Fit the rings to the piston using pliers (88012202), making sure all "Top" markings are facing upwards and gaps are staggered 120° from each other. See Fig. 10.

CRANKSHAFT MAIN & CONNECTING ROD BEARINGS							
Engine	MAIN BEARINGS				CONNECTING ROD BEARINGS		
	Journal Diam. In. (mm)	Clearance In. (mm)	Thrust Bearing	Crankshaft End Play In. (mm)	Journal Diam. In. (mm)	Clearance In. (mm) ①	Side Play In. (mm)
1800 cc	2.086-2.087 (52.985-53.005)	.002-.003 (.050-.094)	Center	.002-.012 (.055-.305)	2.000-2.001 (50.792-50.802)	.0016-.0030 (.041-.075)	.005-.018 (.127-.457)

① — Dimensions given are for Class A Bearing Shells. With Class B Bearing Shells, clearance would be .0017-.0030" (.043-.077 mm) for crankpin journals of 1.999-2.000" (50.782-50.792 mm).

MAIN & CONNECTING ROD BEARINGS

1) With crankshaft removed, check main journal and connecting rod journal diameters. Oversize bearing shells are available if journals require grinding. Check clearance of both crankpin and main bearing journals, using Plastigage method outlined under PISTON & ROD ASSEMBLY.

Main Bearing Shell Thickness

Journal Status	Journal Diameter Inches (mm)	Bearing Shell Thickness Inches (mm)
Standard	2.0860-2.0868 (52.985-53.005)	.0718-.0721 (1.825-1.831)
1st Undersize	2.0810-2.0818 (52.858-52.878)	.0743-.0746 (1.888-1.894)
2nd Undersize	2.0760-2.0768 (52.731-52.751)	.0769-.0771 (1.952-1.958)
3rd Undersize	2.0660-2.0668 (52.477-52.497)	.0819-.0821 (2.079-2.085)
4th Undersize	2.0560-2.0568 (52.223-52.243)	.0869-.0871 (2.206-2.212)
5th Undersize	2.0460-2.0468 (51.969-51.989)	.0919-.0921 (2.333-2.339)

Crankpin Bearing Shell Thickness

Journal Status	Journal Diameter Inches (mm)	Bearing Shell Thickness Inches (mm)
Standard	2.0000-2.0001 (50.792-50.802)	.0600-.0601 (1.523-1.527)
Standard	1.9993-1.9996 (50.782-50.792)	.0601-.0602 (1.527-1.531)
1st Undersize	1.9943-1.9951 (50.655-50.675)	.0624-.0626 (1.586-1.590)
1st Undersize	1.9942-1.9951 (50.655-50.675)	.0650-.0653 (1.590-1.594)
2nd Undersize	1.9893-1.9900 (50.528-50.548)	.0650-.0653 (1.650-1.658)
3rd Undersize	1.9793-1.9801 (50.274-50.294)	.0700-.0703 (1.777-1.785)
4th Undersize	1.9693-1.9701 (50.020-50.040)	.0750-.0753 (1.904-1.912)
5th Undersize	1.9597-1.9605 (49.776-49.796)	.0800-.0803 (2.031-2.039)

1800 CC 4 CYLINDER (Cont.)

2) When reassembling, be sure to align connecting rod caps and rods so that matching numbers align. When installing main bearing caps, front cap is of different shape and caps are numbered for proper installation.

3) Check crankshaft end play. End play is controlled by two half thrust washers in the cap of the rear main journal. Standard width of thrust washers is .0909-.0929" (2.310-2.360 mm). Oversize thrust washers are .0960-.0979" (2.437-2.487 mm) thick.

4) When installing piston on connecting rod, use suitable tool (88012210). The following size connecting rods (bushing inner diameters) are available.

Connecting Rod Bushing Diameters^①

Pin Class	Bushing I.D. Inches (mm)
Class 18663-.8664 (22.004-22.007)
Class 28664-.8665 (22.007-22.009)

① — Inner diameters for clearance purposes should be measured with bushing installed in rod.

FRONT OIL SEAL

Fit the crankshaft front oil seal cover on new gasket. Do not tighten bolts. Place new oil seal in cover and using suitable installing tool (88012313), drive oil seal in by screwing the sheave mounting nut to the crankshaft. Remove the tool, fit the timing belt drive gear to the crankshaft and tighten bolts to secure the oil seal cover.

REAR OIL SEAL & FLYWHEEL

Fit the crankshaft rear oil seal cover on new gasket. Position crankshaft with crankpins for No. 1 and No. 4 cylinders at TDC. Fit flywheel so timing mark registers with TDC for crankpins No. 1 and No. 4. Install flywheel mounting bolts. Install flywheel locking tool (88013347) and torque bolts to 61 ft. lbs. (8.5 mkg).

ANCILLARY DRIVE SHAFT

1) Using installing-removing tool (88012455), drive off crankcase-mounted bearings of ancillary drive shaft. See Fig. 11. Tool features a front end divided in two sections of different diameters to match each bearing's inner diameter.

2) Clean bearing seats and be sure crankcase oilways are not clogged. Using same tool, install smaller diameter inner bearing into its housing. Then install front bearing. Make sure oilways coincide with those present on crankcase.

3) Ream the bearing inner diameter using suitable reamer (88014325). Clean bearings with compressed air through the oilways.

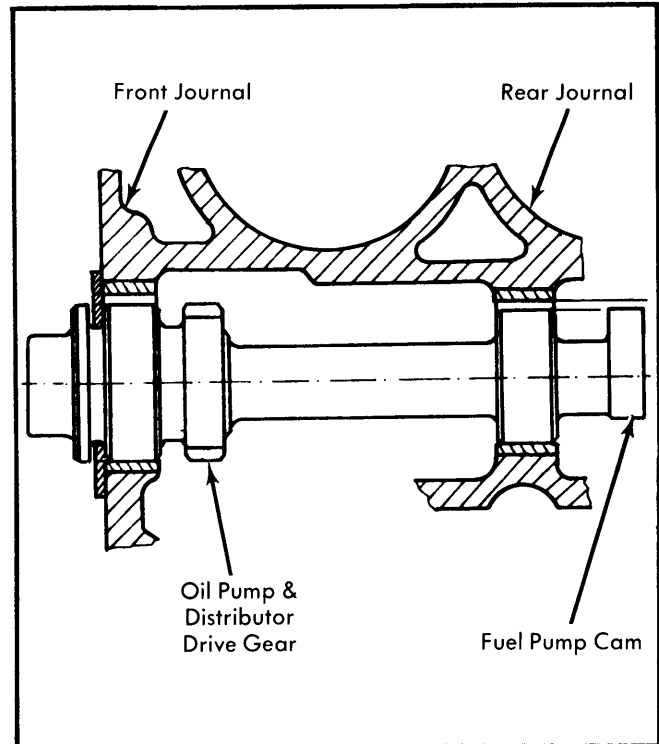

Fig. 11 Ancillary Drive Shaft Components

4) Using similar procedure and removing-installer tool (88012456) drive out oil pump and ignition distributor drive gear bushing. Clean and inspect oilways and bushing seat. If reaming is necessary, use an adjustable reamer (88094053).

NOTE — Front and rear journal clearance should be .0018-.0036" (.046-.091 mm) with an end play of .0028-.0087" (.070-.220 mm).

TIMING BELT

Removal — 1) Remove timing gear cover, spark plugs, and valve covers. Install handles (88013344) on flywheel. Turn crankshaft in direction of rotation until holes in camshaft drive gears (See Fig. 1) align with timing reference pointers. Remove reference pointers bracket. Attach locking fixture (88013039), by engaging dowel pins in camshaft gear timing holes. Attach fixture to cylinder head.

2) Remove belt stretcher nut and bolt and release tension from belt. Slip belt off gears and install new belt every 25,000 miles. Check belt stretcher spring strength using a suitable tool (80015052). Torque spanner (88091134) set at 10 ft. lbs. (1.4 mkg) must yield when reference marks on tool and spring are aligned.

Lancia Engines

1800 CC 4 CYLINDER (Cont.)

Installation – 1) Align reference mark on crankshaft pulley with timing mark on fixture (88013039). When both marks correspond exactly, pistons No. 1 and No. 4 will be at TDC. Fixture reference hole should also line up with ancillary drive shaft reference hole. Check alignment by inserting dowel pin.

2) Install timing belt. Unlock the belt stretcher bolt applying pressure to the belt. Tighten bolt and nut to 32.5 ft. lbs. (4.5 mkg). Once tensioning bolt is torqued, remove fixture (88013039). Turn the crankshaft a few times, partially release the belt stretcher and finally relock it properly. Install timing reference pointers bracket.

2) Remove rear cover plate from camshaft housing and remove camshaft. Using tool (88012315) remove oil seal. Examine camshaft journals and lobes for signs of seizure or scoring. Check camshaft housing bearings for scoring and excessive wear. Check clearances between journals and bearings. See charts for proper clearance. End play should be .0039-.0077" (.100-.195 mm).

3) When installing camshaft gears, reverse procedure and torque camshaft gear bolts to 87 ft. lbs. (12 mkg).

CAMSHAFT			
Engine	Journal Diam. In. (mm)	Clearance In. (mm)	Lobe Lift In. (mm)
1800 cc Front	1.1789-1.1795	.0019-.0035
	(29.944-29.960)	(.049-.090)
Center	1.801-1.802	.0011-.0028
	(45.755-45.771)	(.029-.070)
Rear	1.8171-1.8178	.0011-.0028
	(46.155-46.171)	(.029-.070)

VALVE TIMING				
Engine	INTAKE		EXHAUST	
	Open (BTDC)	Close (ALDC)	Open (BLDC)	Close (ATDC)
1800 cc	5°	53°	53°	5°

CAMSHAFTS

1) With timing belt removed, remove camshaft gears. Attach retainer (88013151) to camshaft drive gears and tighten bolt which clamps the two halves of retainer together. Knock down tab of lock plates and partly unscrew gear securing bolts. Lift off retainer and gears with respective bolts and lock plates.

VALVE TIMING

To check valve timing, turn crankshaft until reference mark on sheave aligns with long mark on timing gear cover. See Fig. 12. Check that the two holes in camshaft gears (one in each) are aligned with reference marks on front camshaft bearings. See Fig. 12. If adjustment is necessary, use tool (88013039) as instructed under *TIMING BELT*.

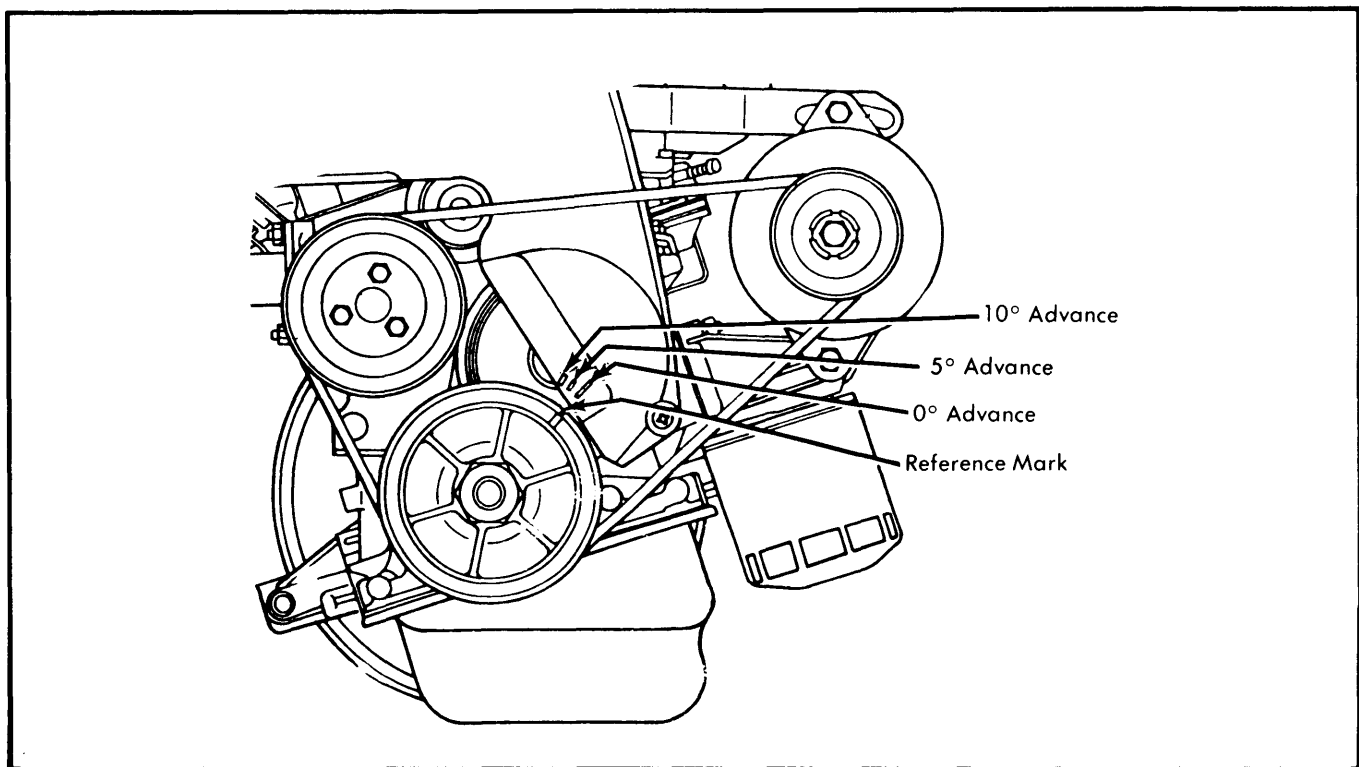

Fig. 12 Valve Timing Reference Marks

1800 CC 4 CYLINDER (Cont.)

ENGINE OILING

Crankcase Capacity — 4.25 quarts (4 ltr) without filter;
5.25 quarts (5 ltr) with filter.

Oil Filter — Full-flow, quick-change. Gauze-type filter in pump strainer.

Normal Oil Pressure — 57-87 psi (4-6 kg/cm²) at 6000 RPM at 185° F (85°).

ENGINE OILING SYSTEM

The gear-type oil pump is driven off the ancillary drive shaft and provides pressure lubrication to all engine parts. A full-flow type oil filter is used along with an oil pressure regulating valve.

OIL PUMP

1) Remove oil pan. Loosen mounting bolts and remove oil pump. Place pump in soft-jawed vise and remove strainer assembly. Remove spring, pressure regulating valve and pump body plate.

2) Remove pump from vise and remove gears from pump body. See Fig. 13. Inspect gears for scoring or "steps" and replace if necessary. Check side clearance between gears and pump body. See Fig. 14. Excessive clearance indicates wear to

drive gear shaft in the pump body or between the driven gear and its shaft.

3) Using "V" blocks and surface plate, check end play with a dial indicator, measuring play between gears and face of pump body. Excessive end play could be due to excessive wear to pump body inner surface, requiring a new pump body, or wear to gear faces, requiring only new gears.

4) Check that face of the pump body plate contacting gears is not scored and that pressure regulator valve seating area is not scored, worn out or otherwise impairing proper valve operation.

5) Check sealing face of the pressure regulating valve. Test spring for strength. It should have a free length of 1.00" (25.2 mm). Under static load of 5.40-6.06 lbs. (2.45-2.75 kg) spring should compress to .59" (15 mm) length. Under dynamic load of 7.65-8.31 lbs. (3.47-3.77 kg), spring should compress to .43" (11 mm).

6) Reassemble pump and insure free movement of gears. Reinstall oil pump, tightening bolts by stages using a criss-cross pattern.

7) Install a new gasket and complete installation of oil pan and parts previously removed. Use tool (88013039) for retiming camshafts and ancillary drive shaft. Lower engine into place on mounting buffers and complete installation.

Oil Pump Specifications

Measurement	Inches (mm)
Drive Shaft Bushing, I.D.	.6305-.6314 (16.016-16.037)
Diameter, Gear Shank	.6287-.6293 (15.970-15.985)
Clearance, Bushing-to-Shaft	.0012-.0026 (.031-.067)
Pump Gear Housing Depth	1.819-1.839 (30.020-30.072)
Pump Gear Thickness	1.1794-1.1807 (29.956-29.989)
Gear End Play	.0012-.0046 (.031-.116)
Clearance, Gear-to-Housing	.0010-.0032 (.026-.080)
Clearance, Gear-to-Gear	.0059 (.15)

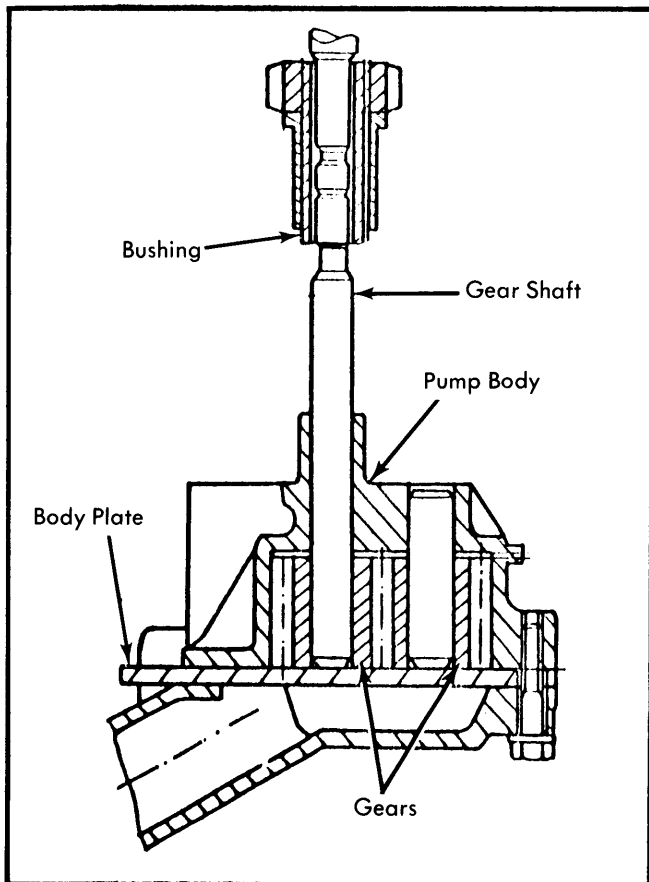

Fig. 13 Oil Pump Components

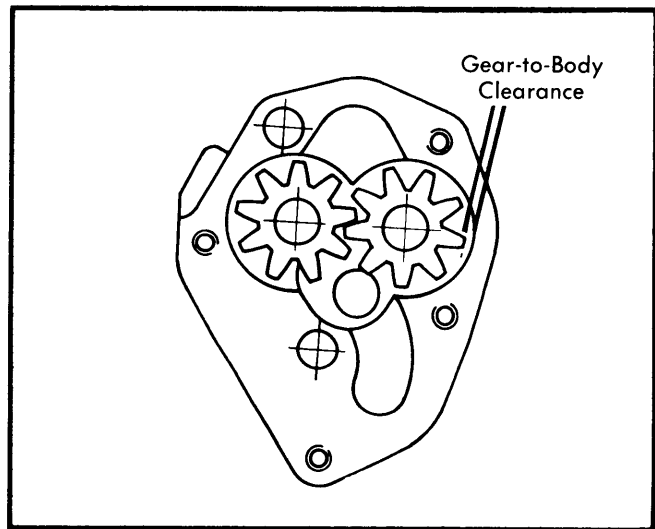

Fig. 14 Checking Oil Pump Gear Side Clearance

Lancia Engines

1800 CC 4 CYLINDER (Cont.)

ENGINE COOLING

Cooling System Capacity - 9 quarts (8.5 ltr).

Thermostat - Coolant blending thermostatic device in water pump inlet pipe. Also equipped with fan control thermostatic switch, which turns on cooling fan at 194-201° F (90-94° C); turns fan off at 185-192° F (85-89° C). Engine overheating warning light switch comes on at 233-244° F (112-118° C).

COOLING SYSTEM

Cooling system features forced coolant circulation with a water pump, radiator, filling and overflow tank, and thermoelectrically controlled cooling fan.

WATER PUMP

1) To remove water pump, remove hub cap and loosen bolts on front right-hand wheel. Lift front end of car and rest it on stands. Drain coolant from radiator and engine block and remove nuts which secure inlet pipe assembly to water pump (from beneath vehicle).

2) Remove right-hand wheel and engine guard. Loosen retaining bolts on water pump sheave and slacken drive belt. Remove drive sheave. Remove timing gear cover, bolts securing pump inlet pipe to mounting bracket of engine anchoring rod, and inlet pipe from water pump.

3) Remove bolts securing pump to the crankcase and lift off pump. Pump assembly is supplied only as a complete unit and cannot be repaired. When installing new pump, use new seal between pipe and water pump. Fill with coolant and check for leaks.

TIGHTENING SPECIFICATIONS

Application	Ft. Lbs. (mkg)
Front Main Bearing Cap Nuts	59.3 (8.2)
Other Main Bearing Cap Nuts	83.2 (11.5)
Flywheel Bolts	61.5 (8.5)
Connecting Rod Cap Nuts	37.6 (5.2)
Cylinder Head Bolts	⓪61.5 (8.5)
Camshaft Housing Nuts	16 (2.2)
Exhaust Pipe Nuts	17.4 (2.4)
Manifold Nuts	18 (2.5)
Crankshaft Nut	181 (25)
Camshaft Gear Bolts	87 (12)
Spark Plugs	27.5 (3.8)
Temperature Gauge Transmitter	36 (5)
Timing Belt Tensioner Nut	32.5 (4.5)

⓪ - Tighten in two stages to final torque setting.