

Jaguar Engines

XJ6 4.2 LITER 6 CYLINDER

GENERAL SPECIFICATIONS										
Year	Displ.		Carburetor	HP at RPM	Torque (Ft. Lbs. at RPM)	Compr. Ratio	Bore		Stroke	
	cu. ins.	cc					in.	mm	in.	mm
1976	258.4	4235	2x1-Bbl.	195 @ 4750	7.5:1	3.625	92.07	4.173	106

ENGINE IDENTIFICATION

Engine can be identified by the number stamped on top of cylinder block at rear of engine and on identification plate in engine compartment. The "L" following the engine number denotes low compression engine.

Beginning serial number for two door models is 2J 50001 and starting serial number for four door models is 2T 50001.

ENGINE REMOVAL

1) Remove hood. Disconnect battery. If equipped with air conditioning, discharge system and disconnect suction and pressure hoses (immediately cap all openings). Remove inlet and outlet fuel pipes at heat exchanger. Plug inlet pipe. Free inlet pipe of all connections and secure out of way (to valance). Remove screws securing heat exchanger. Secure A/C hoses away from engine. Beneath right fender well, remove receiver-drier retaining screws, then secure receiver-drier and hose away from engine.

2) Remove wing valance stays. Remove air cleaner. Detach and remove radiator. Disconnect coolant hoses to expansion tank. Remove both engine mount-to-bracket nuts. Drain power steering fluid. Disconnect power steering lines. Slacken pump mounting bolts and push pump as close as possible to engine.

3) Pull connectors from alternator. Separate connector plug from engine harness. Disconnect brake vacuum pipe at manifold, and secure pipe out of way. Release pipe clip and pull heater-A/C operating vacuum pipe from non-return valves; secure away from engine. Remove exhaust manifolds.

4) Remove starter cable and solenoid cable. Disconnect heater hoses at firewall connectors. Detach inner and outer throttle cables and secure away from engine. Remove choke cables from carburetors and position out of way. Disconnect hoses from charcoal canister.

5) Remove banjo bolt at clutch master cylinder reservoir, release hose from clip and secure across engine. Position suitable lifting device and attach to rear lifting eye. **NOTE** — If vehicle is equipped with manual transmission, position vehicle on hoist or blocks to increase ground clearance by approximately one foot. Remove overdrive switch from gear lever knob, then remove knob from gear lever (if equipped).

6) Remove nut at center of rear gearbox mounting. Unscrew two nuts securing bracket on gearbox. Remove heat shield. Position jack to support mounting plate of transmission, then unscrew four retaining set screws. Lower jack and remove mounting plate (with spring washers and rubber rings).

7) Remove special nuts securing propeller shaft to output flange. Separate gearbox harness at snap connectors (Man. Trans. vehicles). From transmission unit selector lever, remove nut to release ball peg on inner selector cable, and remove setscrew and spring washer securing outer selector cable clamp (Auto. Trans. vehicles). Disconnect speedometer cable from transmission.

8) From front of vehicle, position jack to support assembly beneath transmission oil sump. Support engine on lifting assembly. Carefully lower rear of engine and raise front. **CAUTION** — When maneuvering engine, take care not to damage the air conditioning expansion valve (if equipped). Withdraw engine forward and upward.

CYLINDER HEAD

Removal — 1) Disconnect battery. Drain cooling system. Remove both wing valance stays (firewall-to-fender support rods), removing pressure line from support rod if equipped with air conditioning. Remove air cleaner. Detach inner and outer throttle cables from abutment and linkage brackets. Separate kickdown cable from linkage and retainers (if equipped with Model 65 Auto. Trans.).

2) If equipped with air conditioning, release inlet and outlet fuel line union nuts at heat exchanger. Plug line. Remove clips securing A/C suction line to engine. Remove screws and lay heat exchanger at left side of engine compartment.

3) Release union nut at EGR "Y" connector. Remove four screws and carefully separate cover from secondary throttle housing. Pull vacuum line from EGR valve. **NOTE** — Completion of this step will depend upon whether vehicle is equipped with a fixed orifice EGR valve or a variable orifice EGR valve.

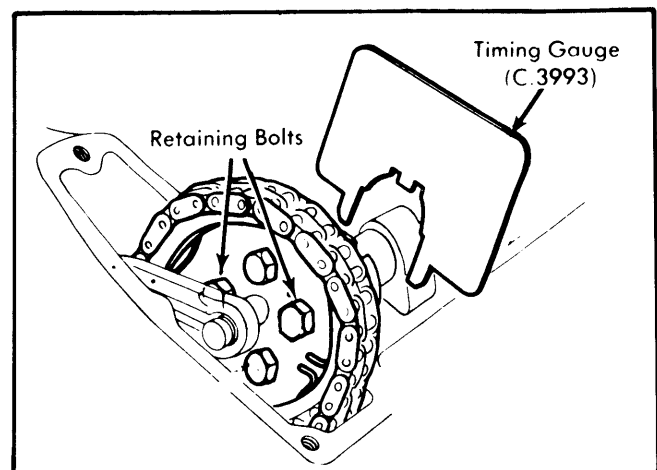

Fig. 1 Retaining Bolts Installed to Hold Camshaft During Cylinder Head Installation

XJ6 4.2 LITER 6 CYLINDER (Cont.)

4) Pull anti-deisel system vacuum line "H" fitting from "T" connector at gulp valve. Detach air line from fresh air injection manifold. Remove float chamber and carburetor breather crossover pipes from rubber connectors and plastic clips; lay these to left side of engine compartment.

5) Slacken pipe clip at air injection manifold check valve, then remove air injection pipe. Remove air pump and bracket. Detach setscrew at rear of cylinder block securing EGR system supply line. Unscrew EGR pipe from exhaust manifold adaptor. Remove adaptor.

6) Remove heat shield from exhaust manifold. Remove steering pump drive belt and swing pump away from engine. Detach top hose from radiator. Pull remote header and radiator bleed lines from header tank. Release coolant hose from water pump. Remove secondary throttle heater hose. Note connections and remove all vacuum lines and wires from beneath intake manifold.

7) Remove exhaust manifolds from cylinder head. Disconnect two camshaft oil lines from rear of head. Remove distributor cap, spark plugs, and plug wires. Unbolt and remove camshaft covers. Detach breather housing from front of head.

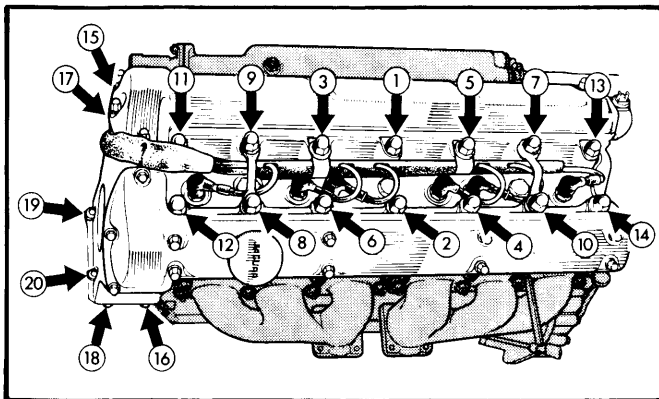

Fig. 2 Jaguar Cylinder Head Tightening Sequence

8) Remove camshaft sprocket retaining bolt (from both camshafts), then rotate engine until remaining two bolts are accessible and remove both bolts. **CAUTION** — The engine must not be rotated after camshaft sprockets are disconnected and cylinder head is still in place. Withdraw camshaft sprockets. Mark aligning holes in adjuster plates.

9) Working from center outward, remove cylinder head retaining bolts and nuts, and lift head from engine. **CAUTION** — Do not rest cylinder head on flat surface. Support head with wooden blocks at each end of mounting face to protect open valves which protrude.

Installation — 1) Install new head gasket (ensuring "TOP" mark is upward). Rotate crankshaft until No. 6 cylinder (front) is at TDC, with rotor pointing approximately forward along engine.

2) Rotate camshafts until suitable timing gauge (C.3993) can be located in front flange slots (Fig. 1). Lower cylinder head into position, attach spark plug wire brackets and lifting brackets to appropriate head studs, then place washers and 14 large domed nuts on stud. Affix nuts and washers at forward end of head, then tighten all nuts (Fig. 2).

3) Locate sprockets on camshaft flanges and ensure both holes in each flange are positioned with aligning holes marked during removal. If necessary, remove circlip and reposition adjuster plate. Make sure engine is not rotated until camshaft sprockets are fully seated and chain installed.

4) Secure each adjuster plate to camshaft, then rotate engine until remaining attachment holes are accessible. Install bolts and bend up lock plate tabs. Set timing chain tension using a suitable adjusting tool (JD2B). Tighten lock nut.

5) Ensure No. 6 (front) cylinder is at TDC and recheck position of camshafts using timing gauge (C.3993). Complete installation by reversing remainder of removal procedures. Recheck ignition timing and perform exhaust emission check.

VALVES

Engine & Valve	Head Diam. In. (mm)	Face Angle	Seat Angle	Seat Width In. (mm)	Stem Diameter In. (mm)	Stem Clearance In. (mm)	Valve Lift In. (mm)
4235 cc Intake	1.75 (44.45)	45°	45°310-.3125 (7.87-7.94)	.001-.004 (.025-.10)	.375 (9.525)
Exhaust	1.625 (41.28)	45°	45°310-.3125 (7.87-7.94)	.001-.004 (.025-.10)	.375 (9.525)

VALVE ARRANGEMENT

Left Side — All exhaust.
Right Side — All intake.

VALVE GUIDE SERVICING

Check valve guide for wear and proper guide-to-valve stem clearance. If guide is worn beyond specifications, replace

guide by heating head in boiling water for approximately 30 minutes (or by other suitable method), then drive guide(s) out of head from combustion chamber end. Coat new guide with graphite grease and refit circlip. Reheat head and drive new guide in from top until circlip is seated in groove. **NOTE** — When installing oversize replacement guides, check O.D. of guide to be used, and if necessary, ream cylinder head bore to obtain proper interference fit.

XJ6 4.2 LITER 6 CYLINDER (Cont.)

Replacement Valve Guides

Application	Size Mark	Dimension In. (mm)
Standard	No Mark	.501-.502 (12.73-12.75)
1st Oversize	1 Groove	.503-.504 (12.78-12.80)
2nd Oversize	2 Grooves	.506-.507 (12.85-12.88)
3rd Oversize	3 Grooves	.511-.512 (12.98-13.00)

VALVE SPRINGS			
Engine	Free Length In. (mm)	PRESSURE Lbs. @ In. (kg @ mm)	
		Valve Closed	Valve Open
4235 cc Inner	1.734 (44.04)
	Outer	2.103 (53.42)

VALVE SPRING SERVICING

CAUTION — Support ends of cylinder head with wooden blocks to prevent damage to valves. Opened valves protrude below face of cylinder head.

- 1) Remove camshaft bearing caps, note markings for reassembly. Remove camshaft, tappets and adjusting pads. Retain tappets and pads in proper order for reassembly.

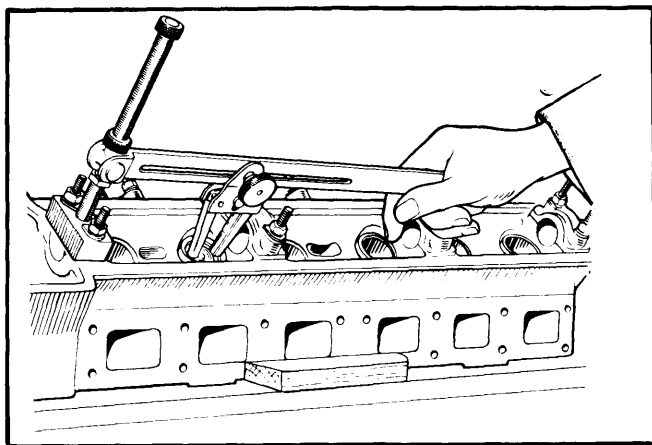

Fig. 3 Using Special Valve Spring Compressor Tool No. JD.6118C to Remove Spring

- 2) Install suitable spring compressor (Churchill No. JD.6118C) and a block of wood between valve and work table. Compress springs and remove valve keepers. Compare old spring with new spring or with specification table. Replace springs as necessary. To install, reverse procedure.

VALVE TAPPET SERVICE

Remove tappets and adjusting pads, keeping components in order. **NOTE** — Valves are numbered and must be kept in

order (if removed). No. 1 is at flywheel end of engine. Inspect all tappets, guides, and adjusting pads for wear. If tappet guide is to be replaced, bore out old guide until it collapses (taking care not to damage head bore). Ensure head is at room temperature and measure tappet guide bore, then grind replacement guide to obtain a .003" (.076 mm) interference fit. Also grind the same amount from the "lead in" at the bottom end of guide. Heat head and drive in tappet guide, then ream guide to 1.75" (44.5 mm). Replace other necessary parts.

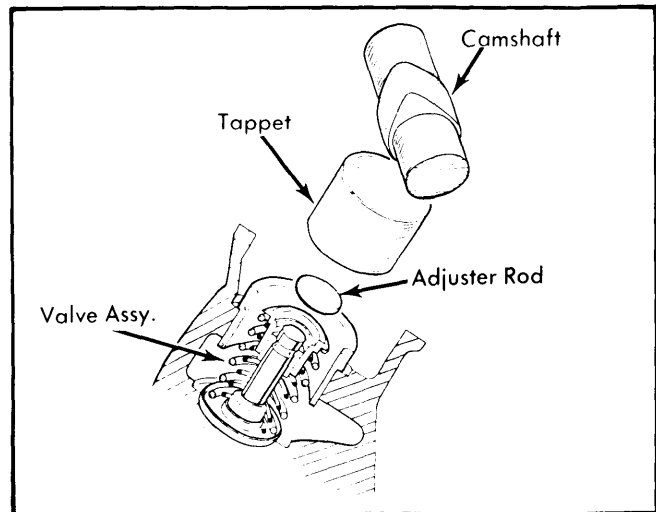

Fig. 4 Expanded View of Valve and Tappet Assemblies

NOTE — It is essential that tappet guide bore is concentric with valve guide bore.

VALVE TAPPET CLEARANCE

NOTE — If checking valve clearances with cylinder head removed, the camshafts must be installed and checked one at a time. It is imperative that this be followed, as position fouling is likely if camshafts are rotated independently while both are installed.

- 1) If not already done, remove camshaft covers. Rotate camshaft and record clearance between heel of each cam and its respective tappet. If head is installed, and adjustment is to be made, rotate camshaft and install valve timing gauge (C.3993) before removing final camshaft retaining bolt. If required, disconnect sprockets from camshafts. See Valve Timing.
- 2) Remove camshaft bearing caps and lift off camshaft. Remove each tappet taking note of its location. Remove adjusting pad. Subtract appropriate valve clearance of .012-.014" (.305-.356 mm) from initial clearance measured. Select appropriate adjusting shim which will equal this measurement. Adjusting pads are available in increments of .001" (.03 mm) from .085" (2.16 mm) to .110" (2.79 mm) and are marked with letters from "A" to "Z" respectively.
- 3) Insert adjusting pads and install tappets. Attach camshafts (using timing gauge if head is installed). Torque camshaft bearing cap nuts, connect camshaft sprockets, and install camshaft covers.

XJ6 4.2 LITER 6 CYLINDER (Cont.)

PISTONS, PINS, RINGS						
Engine	PISTONS	PINS		RINGS		
	Clearance In. (mm)	Piston Fit In. (mm)	Rod Fit In. (mm)	Rings	End Gap In. (mm)	Side Clearance In. (mm)
4235 cc	.0007-.0013 (.018-.033)	① Press Fit	② Push Fit	No. 1	.015-.020 (.38-.51)	.0015-.0035 (.038-.089)
				No. 2	.009-.014 (.23-.35)	.0015-.0035 (.038-.089)
				Oil	.015-.045 (.38-1.14)	③

① — When heated to 230°F (110°C). ② — At room temperature, without piston. ③ — Self-expanding.

OIL PAN REMOVAL (ENGINE INSTALLED)

1) Remove front suspension components to gain access and suitable clearance. Drain engine oil. Remove nuts securing oil return pipe. Unscrew nuts, bolts, and washers securing transmission oil cooler pipe clips (Auto. Trans.).

2) Remove setscrews and nuts retaining oil pan to block (note location of short screw at right front). Unbolt and remove intake strainer box.

3) When installing, ensure "O" ring is properly positioned on oil return pipe. Lightly coat new oil seal with grease and locate in oil pan groove (DO NOT trim seal ends, press into groove until flush). Lightly coat new pan gasket and install pan. Reverse remaining procedures.

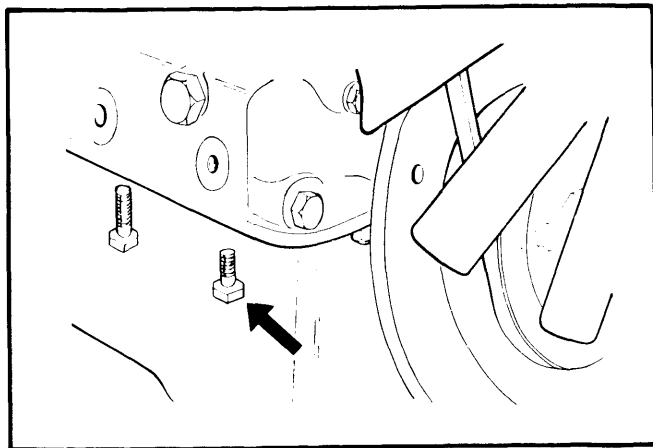

Fig. 5 Position of Short Screw in Oil Pan

PISTON & ROD ASSEMBLY

1) With cylinder head and oil pan removed, unscrew nuts from connecting rod caps, and remove caps, keeping in order for reassembly. **NOTE** — Rod caps and rods are numbered to correspond to their positions (No. 1 is at flywheel end). Remove connecting rod bolt and withdraw piston and rod assembly out top of cylinder.

2) If installing original assemblies, ensure they are replaced in original cylinders. If installing new assemblies, stamp-mark assemblies with numbers "1" through "6". Position pistons in cylinders with "FRONT" mark forward.

PISTON RINGS

After checking ring end gap and side play, install compression rings in top two grooves and oil ring in bottom groove. Both compression rings have tapered peripheries and are marked with "TOP" to ensure correct installation. The top ring is also chrome-plated and cargraph (red) coated; the red coating must NOT be removed. When fitting oil ring, ensure expander ends do not overlap.

PISTON PINS

When removing and replacing piston pins, immerse assembly in hot oil bath (or use other suitable method) to bring piston end of assembly to approximately 230°F (110°C). When installing pins, always use new pin circlips. Note that pins are color coded for grading purposes. Always select proper color pin for replacement.

FITTING PISTONS

Check piston and cylinder bore to determine if proper clearance exists. If necessary to rebore cylinder for installation of oversize piston, note that reboring is not to exceed .030" (.76 mm). Oversize pistons are available in .010", .020", and .030" (.25 mm, .51 mm, and .76 mm) oversizes. If replacing pistons with standard sizes (no reboring), note the following list of piston grades and select replacement piston of same grade. Piston grade is stamped in piston crown and on top face of block adjacent to cylinder.

Standard Piston Grading

Stamp Mark	Cylinder Diameter In. (mm)
F	3.6250-3.6253 (92.075-92.083)
G	3.6254-3.6257 (92.085-92.093)
H	3.6258-3.6261 (92.095-92.103)
J	3.6262-3.6265 (92.106-92.113)
K	3.6266-3.6269 (92.116-92.123)

Jaguar Engines

XJ6 4.2 LITER 6 CYLINDER (Cont.)

CYLINDER LINERS

1) Should piston-to-cylinder clearance be excessive and reboring requires more than .030" (.76 mm) to clean up cylinders, new cylinder liners must be installed.

2) Press out the worn liners from below, using a suitable block. Lightly coat outer top half of new liner with a jointing compound, then press in new liner until flush with top of block. Smear more jointing compound around area of liner-to-block mating surface.

3) Bore out liner to correspond with grade of piston to be installed. Following reboring process, the blanking plugs in the main oil gallery should be removed and cylinder block oilways thoroughly cleaned. When dry, coat interior of crankcase with an oil and heat resistant paint.

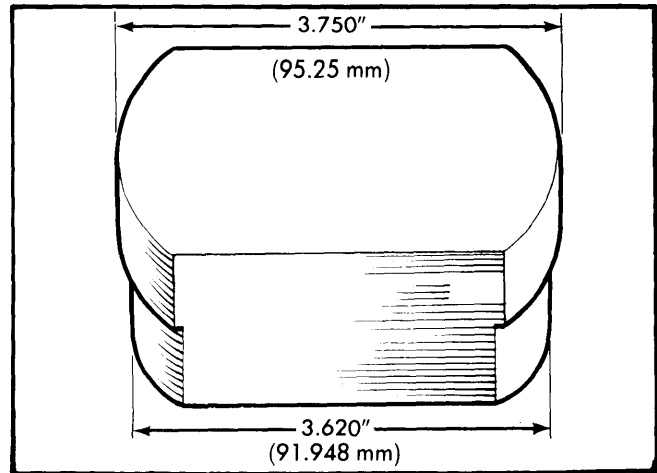

Fig. 6 Special Tool for Removing and Installing Cylinder Liners

CRANKSHAFT MAIN & CONNECTING ROD BEARINGS							
Engine	MAIN BEARINGS				CONNECTING ROD BEARINGS		
	Journal Diam. In. (mm)	Clearance In. (mm)	Thrust Bearing	Crankshaft End Play In. (mm)	Journal Diam. In. (mm)	Clearance In. (mm)	Side Play In. (mm)
4235 cc	2.749-2.750 (69.85-69.86)	.0008-.0025 (.020-.063)	Center	.004-.006 (.10-.15)	2.086-2.0866 (52.98-53.00)	.001-.0027 (.025-.069)	.0058-.0087 (.147-.221)

THRUST BEARING ALIGNMENT

Thrust bearing washers are used on center main bearing caps. Install thrust washers with white metal side outwards (see illustration). Check crankshaft endplay, install thrust washers giving proper clearance. Thrust washers come in standard and .004" (.10 mm) oversize.

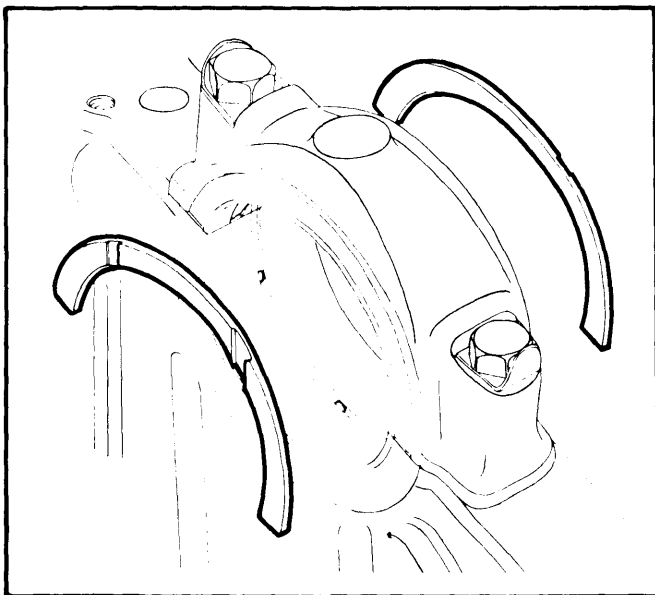

Fig. 7 Position of Thrust Washers on Crankshaft

MAIN BEARING SERVICE

Remove connecting rod and main bearing caps, retaining all parts in exact order for reassembly. Note that all caps are numbered for reassembly reference. When wear or out-of-roundness exceeds .003" (.08 mm), regrind crankshaft and install undersize bearings. Bearings are available in .010", .020", .030", and .040" (.25 mm, .51 mm, .76 mm, and 1.02 mm) undersizes. If regrinding must exceed .040" (1.02 mm), replace crankshaft.

REAR MAIN BEARING OIL SEAL

NOTE — The following procedure must be performed before crankshaft is reinstalled.

1) Carefully tap new rear oil seal halves into position, then roll seal into housing (with a hammer handle) until ends do not protrude. **NOTE** — DO NOT cut seal ends. When both halves are properly in place, secure them with Allen screws.

2) Attach rear main bearing cap without bearings and torque to 72 ft. lbs. (10 mkg). Assemble rear oil seal housing to cylinder block, using three Allen screws. Lightly coat inside surface of oil seal with graphite grease and insert a suitable sizing tool (JD.17B) as shown in illustration. Press tool inward and turn until it is fully seated; this should properly size the oil

XJ6 4.2 LITER 6 CYLINDER (Cont.)

seal. Remove sizing tool by pulling and twisting in opposite direction. Remove oil seal housing and install crankshaft.

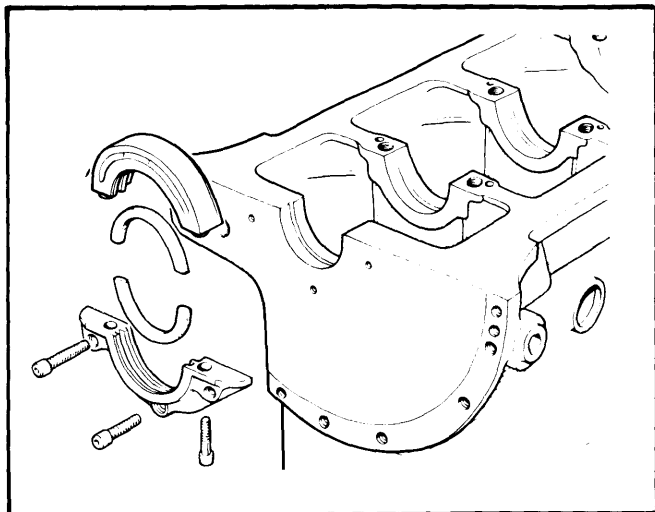

Fig. 8 Expanded View of Crankshaft Rear Oil Seal

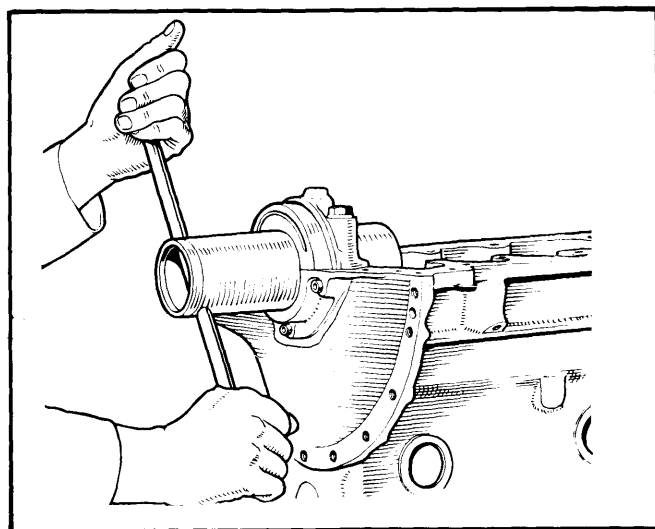

Fig. 9 Using Special Tool to Size Rear Oil Seal

ENGINE FRONT COVER & OIL SEAL

Removal – 1) Remove radiator and fan belt. Mark position of vibration damper for reassembly. Remove pulley. Using a pair of levers, pry damper off of split cone. Remove split cone.

2) Remove oil pan and water pump. Unscrew screws attaching timing cover and slide timing cover and oil seal off of crankshaft.

Installation – 1) Place new seal in groove in timing cover. Using a new gasket and sealing compound, install timing cover and seal. Reinstall oil pan with a new gasket. Install short screw in front right hand corner of oil pan.

2) Reinstall split cone on crankshaft. Position crankshaft damper to mark, install pulley and torque attaching bolts to specifications. Reinstall remaining components in reverse of removal procedures.

CAMSHAFT			
Engine	Journal Diam. In. (mm)	Clearance In. (mm)	Lobe Lift In. (mm)
4235 cc	.9990-.9995 (25.375-25.387)	.0005-.002 (.013-.05)

CAMSHAFT

1) After removing necessary components to gain access to camshaft covers, unscrew ten dome head nuts and two cross head screws which retain each camshaft cover. Detach crankcase breather from front of head. Use a suitable tool (JD.2B) to slacken timing chain (rotate tool in clockwise direction).

2) Bend back tabs from camshaft sprockets and remove two top bolts from each camshaft sprocket, then rotate engine to gain access to other two screws. Rotate engine further until valve timing gauge (C.3993) can be installed. **CAUTION** – Engine is not to be rotated once sprockets are removed from camshafts. Draw sprockets from camshafts and slide sprockets up support brackets. Mark attachment holes in adjuster plate for reassembly reference. Remove camshaft bearing cap retaining nuts and withdraw camshaft. Keep all components in proper order for reassembly.

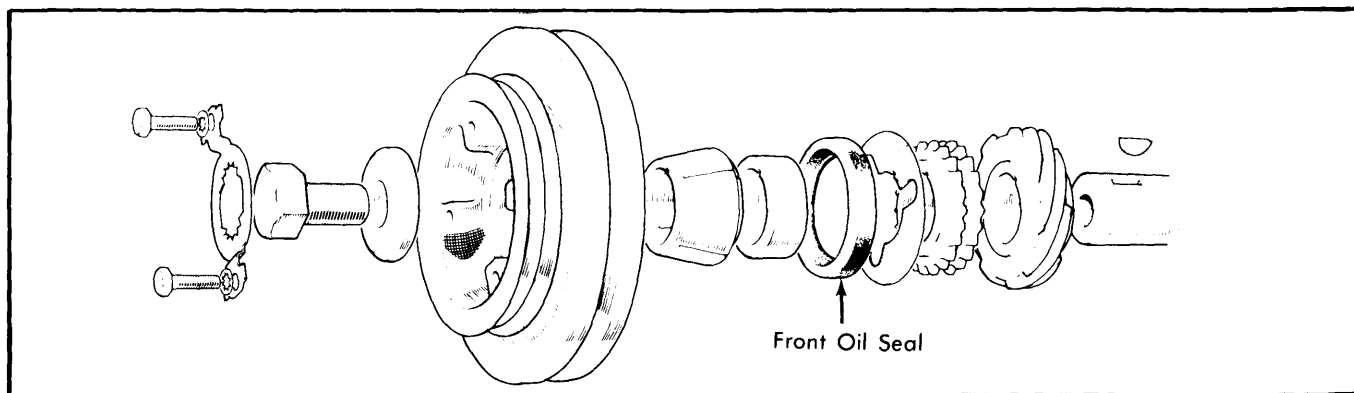

Fig. 10 Exploded View of Crankshaft Damper with Detail of Oil Seal

Jaguar Engines

XJ6 4.2 LITER 6 CYLINDER (Cont.)

VALVE TIMING				
Engine	INTAKE		EXHAUST	
	Open (BTDC)	Close (ABDC)	Open (BBDC)	Close (ATDC)
4235cc	15°	57°	57°	15°

TIMING CHAIN REPLACEMENT

Removal – 1) Remove cylinder head, oil pan, water pump, crankcase breather, vibration damper (including cone and Woodruff key), and timing gear cover. Withdraw timing pointer, distance piece, and front oil seal.

2) Remove oil slinger from crankshaft. Unscrew two bottom timing chain tensioner and chain guides retaining screws. Withdraw conical filter behind tensioner. Slacken four setscrews securing top timing chain assembly (do not remove setscrews at this point).

3) Withdraw crankshaft timing sprocket and chain assembly. Be sure to remove spacers, top timing chain damper, and top timing chain retainer. Disengage camshaft sprockets from top chain. Remove nut and serrated washer from idler shaft and withdraw serrated plate, plunger, and spring.

4) Remove nuts retaining front mounting bracket to rear mounting bracket. Remove timing chains from intermediate and idler sprockets. Draw idler shaft, idler sprocket, and bushing from rear mounting bracket. Remove circlip and press intermediate shaft from rear mounting bracket. Note location of bushing and shim under intermediate sprocket.

Installation – 1) Position eccentric idler shaft to hole in front mounting bracket. Position spring and plunger in bracket and locate serrated plate on shaft. Loosely secure plate using washer and nut.

2) Attach idler sprocket (21 teeth) to idler shaft. Replace intermediate sprocket (large gear forward) onto intermediate shaft, placing shim in position. Install shaft assembly in rear mounting bracket, ensuring roll pin engages in slot; retain with circlip.

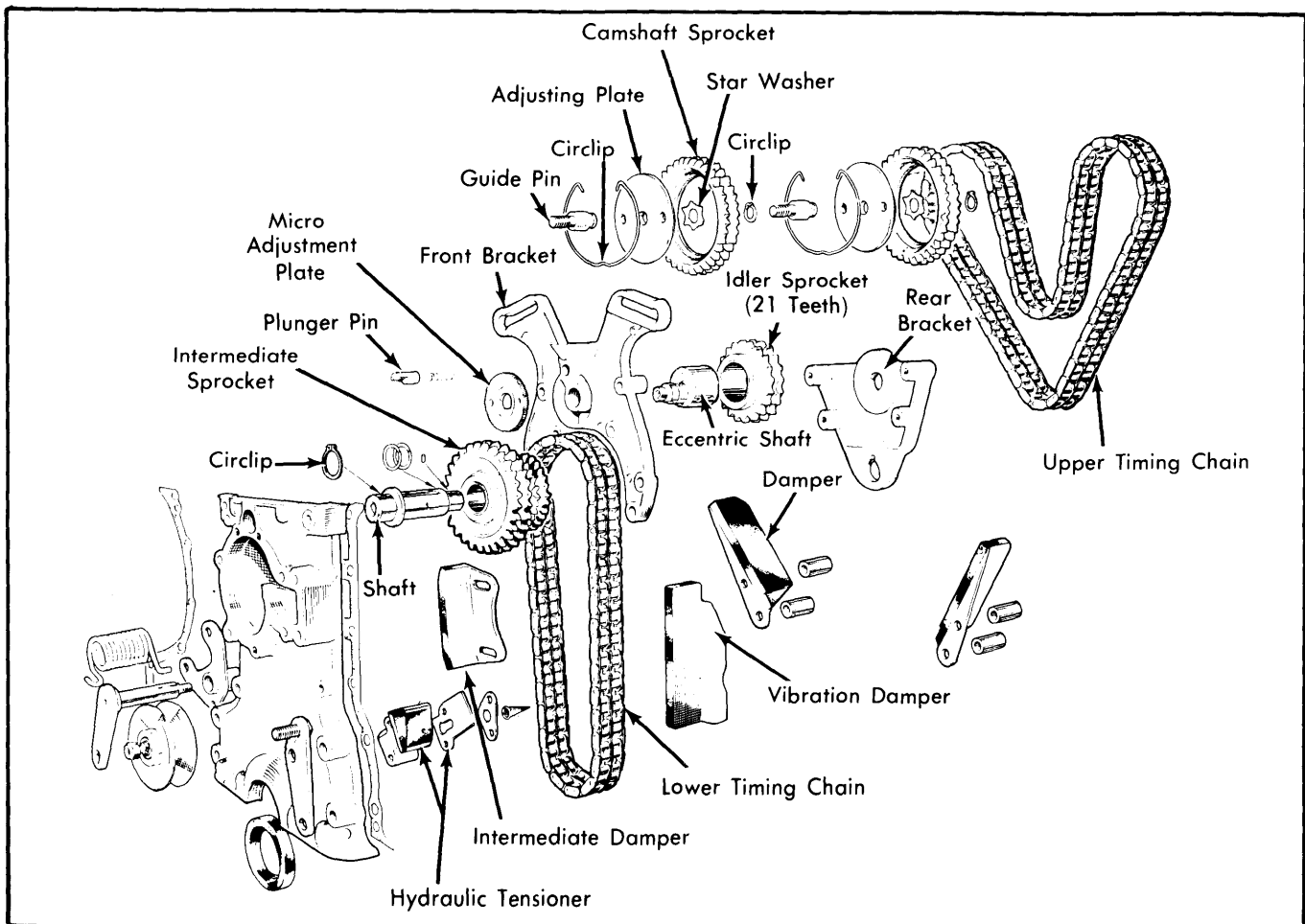

Fig. 11 Exploded View of Timing Gear Assembly

XJ6 4.2 LITER 6 CYLINDER (Cont.)

3) Locate top timing chain (longer) on small intermediate sprocket, and lower timing chain on large sprocket. Loop top chain beneath idler sprocket and secure top mounting bracket to rear bracket.

4) Install four long setscrews and spring washers to front mounting bracket and attach dampers, chain support plate, and spacers to setscrews. Equalize loops of top timing chain and locate camshaft sprockets in loops. Rotate eccentric idler shaft to lift idler sprocket to its highest position between camshaft sprockets.

5) Ensure Woodruff key is positioned in crankshaft. Locate crankshaft sprocket, but do not fully seat at this time. Loop bottom timing chain beneath crankshaft sprocket, then tap sprocket until it is fully seated. Position and secure crankshaft sprocket assembly.

6) Install, but do not tighten, bottom timing chain guides. Insert conical filter into its hole in cylinder block. Screw slipper into tensioner until .125" (3.17 mm) exists between slipper and body. Locate tensioner on shims as necessary to ensure slipper runs central on chain, and secure using two setscrews and lock plate.

7) Place slip gauge or spacer card supplied with new tensioner between slipper and body of tensioner to maintain dimension set earlier, then adjust intermediate damper to touch chain. Tighten setscrews and bend up tabs of lock plate. Remove slip gauge and top chain or tensioner slipper to release ratchet. Position oil slinger on crankshaft. Replace timing cover.

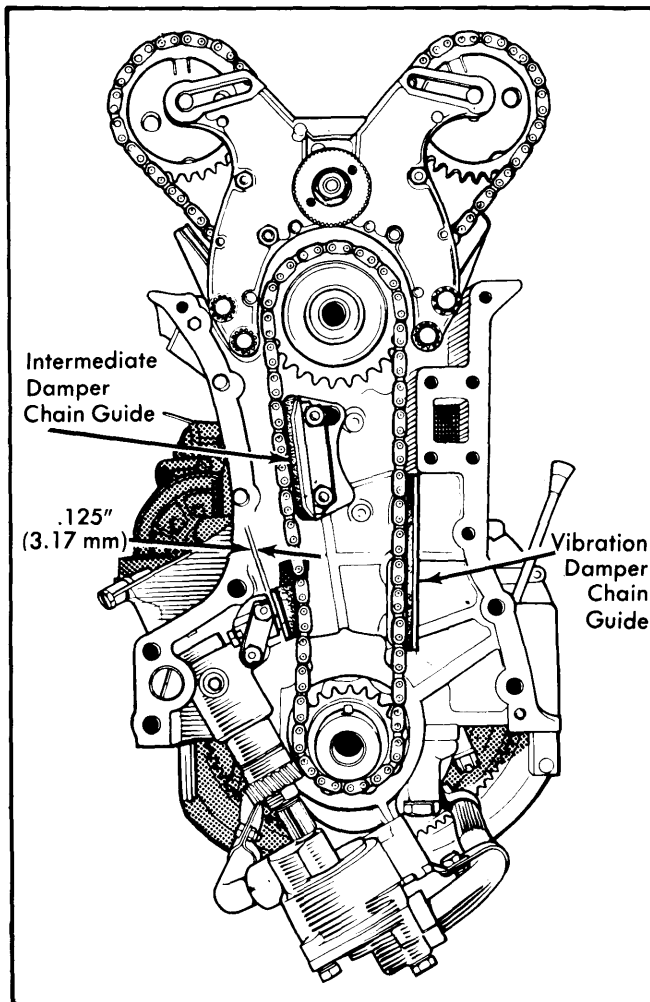

Fig. 12 Lower Timing Chain Adjustment Measurement Point

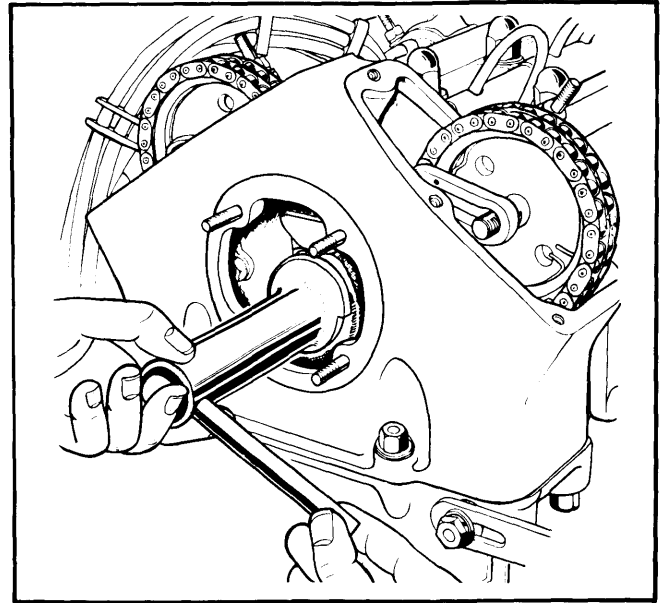

Fig. 13 Making Upper Timing Chain Adjustment

VALVE TIMING

1) Rotate engine so that No. 6 (front) piston is at TDC on compression stroke, and distributor rotor arm points at No. 6 segment. Check that timing chains are properly adjusted. See *Timing Chain Replacement*.

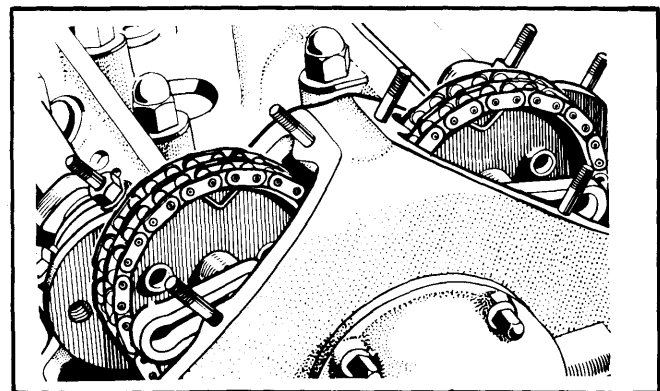

Fig. 14 View Shows Camshaft Sprockets in Disconnected Position

2) Remove lock wire from camshaft sprocket screws. Rotate engine until inaccessible screws can be removed. Return engine to TDC of No. 6 piston and remove remaining screws. Tap camshaft sprockets off camshaft flanges.

3) Accurately position camshafts with valve timing gauge (Fig. 14), and check that TDC marks are in exact alignment. Withdraw circlips from camshaft sprocket assembly and press adjusting plates forward until serrations disengage (Fig. 14).

Jaguar Engines

XJ6 4.2 LITER 6 CYLINDER (Cont.)

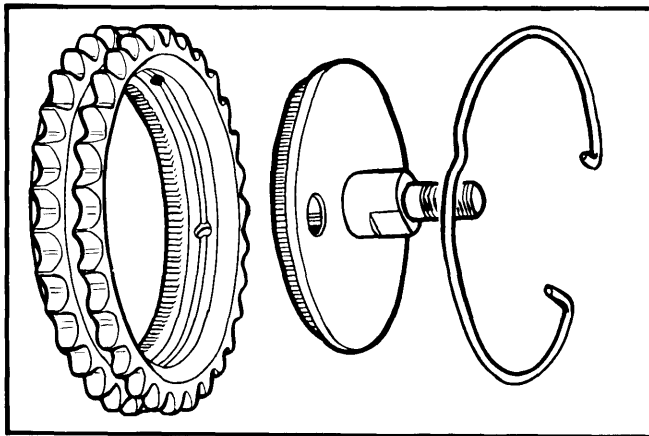

Fig. 15 Expanded View of Camshaft Sprocket Assembly

4) Replace sprockets on flanges of camshaft and align two holes in adjuster plate with holes in flanges. Engage serrations of adjuster plates with serrations in sprocket.

NOTE — Screw holes must be in exact alignment. If difficulty is experienced in aligning holes turn adjuster plates 180° and realign holes.

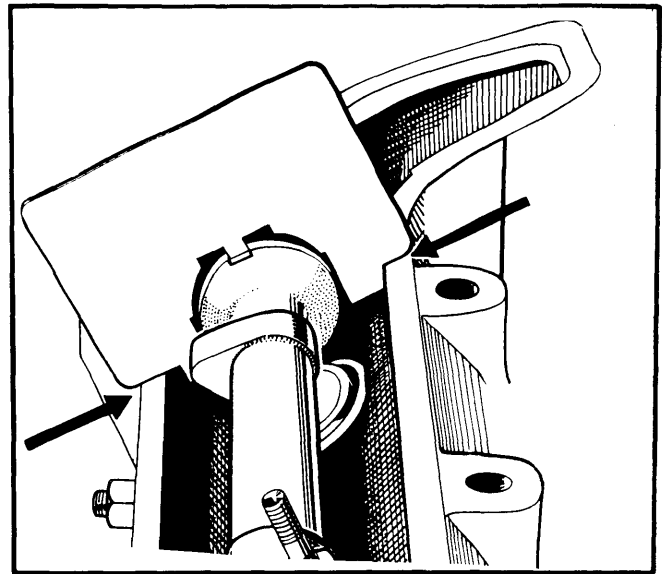

Fig. 16 Valve Timing Guide Inserted in Position

5) Replace circlips in camshaft sprockets. Replace camshaft sprocket screws and lock wire. Recheck valve timing.

ENGINE OILING

ENGINE OILING SYSTEM

Lubrication is provided by a gear driven eccentric rotor type pump. Oil from pump goes through a full-flow oil filter to all moving engine components.

Crankcase Capacity — 7.2 qts.

Oil Filter — Replace every 3,000 miles.

Normal Oil Pressure (Hot) — 40 psi @ 3,000 RPM.

OIL PUMP

Removal — Remove oil pan, suction and delivery pipes. Remove bolts attaching oil pump to front main bearing cap. Withdraw pump and coupling sleeve at top of drive shaft.

Disassembly — 1) Remove bolts and take off bottom cover. Remove inner and outer rotors. Inner rotor is pinned to drive shaft and cannot be disassembled.

2) Check clearances of inner and outer rotor lobes, outer rotor-to-body and rotor-to-cover plate. Place drive shaft in a soft jawed vise and check that rotor is tight on pin.

NOTE — Drive shaft, inner and outer rotors are supplied as an assembly only.

Assembly — Reassemble in reverse order of disassembly. Install outer rotor to pump body with chamfered end forward. Use new "O" rings on suction and delivery pipes. To install, reverse removal procedures.

Oil Pump Specifications

Application	Clearance In. (mm)
Inner-to-Outer Rotor006 (.15)
Outer Rotor-to-Body010 (.25)
Rotor-to-Cover (End Play)0025 (.06)

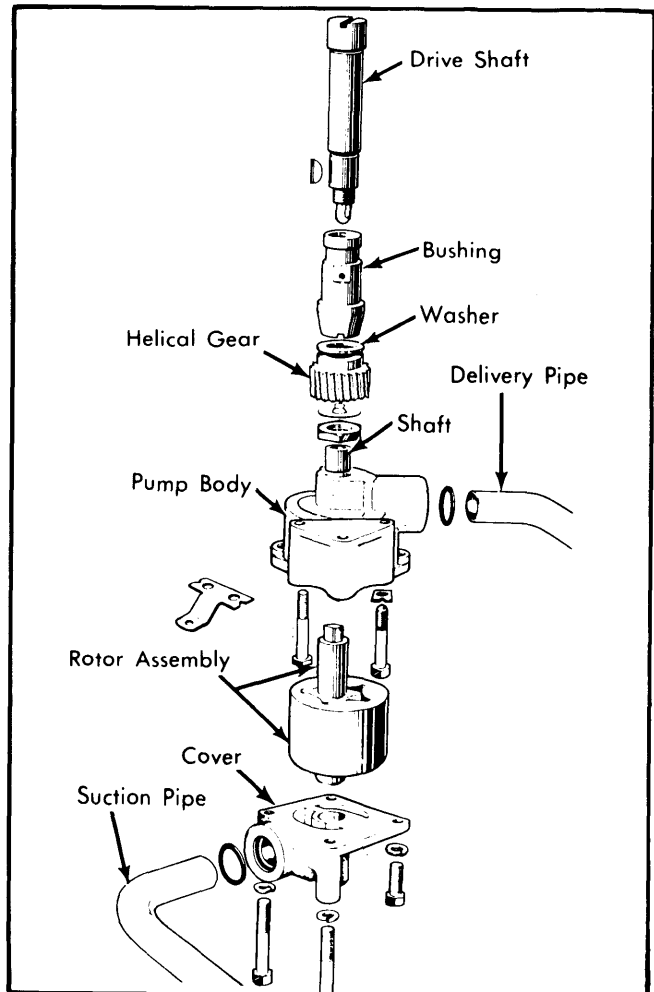

Fig. 17 Exploded View of Jaguar Oil Pump Assembly

XJ6 4.2 LITER 6 CYLINDER (Cont.)

ENGINE COOLING

WATER PUMP

Disassembly – 1) Remove water pump and gasket from timing cover. Pull fan hub from shaft with a puller. Loosen lock nut and remove Allen locating screw.

2) Using an arbor press and a tube measuring 1 3/32" O.D. and 31/32" I.D., press shaft and impeller assembly out of pump body. Do not press on shaft or bearing will be damaged.

3) Press shaft from impeller and remove seal and rubber thrower. Spindle and bearing assembly cannot be further disassembled.

4) Clean and inspect all parts for wear or damage. Bearing is sealed and lubricated, therefore do not wash in solvents.

Assembly – 1) Install shaft and bearing assembly into pump body from rear. Align and install locating screw and lock nut. Place rubber thrower in its groove on shaft in front of seal.

2) Coat outside of brass seal housing with suitable water resistant sealer and install into recess in pump housing. Push seal into its housing with carbon face towards rear of pump.

3) Press impeller onto shaft until rear face of impeller is flush with end of shaft. Press fan hub onto shaft until it is flush with end of shaft.

Cooling System Capacity – 19.25 qts.

TIGHTENING SPECIFICATIONS	
Application	Ft. Lbs. (mkg)
Cylinder Head Nuts	54 (7.5)
Main Bearing Caps	72 (10)
Connecting Rod Caps	37.5 (5.1)
Flywheel	67 (9.2)
Camshaft Cap	9 (1.2)
Torque Converter	35 (4.8)
Camshaft Cover	5-6 (.7-8)
Rear Engine Mount-to-Body	
5/16" Bolt	14-18 (1.9-2.5)
3/8" Bolt	27-32 (3.7-4.4)
Front Engine Bracket-to-Beam	14-18 (1.9-2.5)