

124 & 131 4 CYLINDER

GENERAL SPECIFICATIONS										
Year	Displ.		Carburetor	HP at RPM	Torque (Ft. Lbs. at RPM)	Compr. Ratio	Bore		Stroke	
	cu. ins.	cc					in.	mm	in.	mm
1976	107.13	1756	1x2-Bbl.	①86@6200	②90@2800	8.0-1	3.31	84	3.12	79.2

- ① — 83@5800 when equipped with catalytic converter.
 ② — 86@2800 on 131 models or 89@2800 on 124 models when equipped with catalytic converter.

ENGINE IDENTIFICATION

Engine identification number is stamped in pad above oil filter mount on left side of engine.

Application	Engine Code
124 models	
With Catalytic Converter	132 A1.031.6
Without Catalytic Converter	132 A1.040.6
131 models	
All	132 A1.040.5

ENGINE REMOVAL

- 1) Disconnect battery and all electrical connections to engine. Drain cooling system, remove shroud, all hoses and radiator. Remove air cleaner.
- 2) Disconnect accelerator cable at lever on dash and starting device cable at lever on carburetor. Disconnect fuel inlet line to fuel pump and fuel overflow line from carburetor to tank.
- 3) Disconnect power brake unit vacuum line from manifold (if equipped). From inside driver's compartment, press down on gear shift lever and pry out retaining ring with a screwdriver.
- 4) Remove transmission cover. From under vehicle, disconnect drive shaft from transmission and remove drive shaft safety cross strap. Remove drive shaft center pillow block.
- 5) Disconnect speedometer drive from transmission. Disconnect back-up light switch cables at transmission (if equipped). Disconnect clutch fork return spring and remove adjusting rod.
- 6) Remove inspection cover from bottom of clutch housing. Disconnect exhaust pipe support bracket from rear of transmission and remove starter from clutch housing.
- 7) Position a suitable transmission holding fixture (A. 70509) to a floor jack and position under transmission. Remove bolts securing transmission to engine and remove rear crossmember.
- 8) With transmission supported by jack, pull to rear until input shaft clears release bearing. Lower jack when transmission is clear and remove from under vehicle.
- 9) Remove clutch assembly from flywheel. Attach a suitable lifting fixture to engine, raise slightly and remove nuts securing engine to front motor mounts. Lift engine up and remove.
- 10) To install engine and transmission, reverse removal procedure. Make sure engine and transmission connect properly.

CYLINDER HEAD

Removal — 1) Disconnect battery, drain cooling system and remove air cleaner. Disconnect water temperature sending unit connection and spark plug wires. Disconnect water hoses.

2) Disconnect accelerator cable from lever on firewall and disconnect accelerator rod from lever on carburetor. Disconnect fuel line and fuel overflow from carburetor. Disconnect power brake vacuum line and starter relay cable. Disconnect all other pipes, hoses and wires to intake manifold and cylinder head.

3) Disconnect exhaust pipe from manifold and remove starter heat shield. Remove timing belt. See *Timing Belt Replacement*. Remove cylinder head retaining bolts and remove cylinder head.

Installation — 1) Before installation of cylinder head, position camshafts so that reference marks on sprockets are aligned with fixed pointers on front of cylinder head.

2) When installing cylinder head, camshafts must not be moved in either direction. Rotate crankshaft and bring pistons number 1 and 4 to TDC.

3) Install two dummy studs in one cylinder head bolt hole at front and rear of engine. Install new cylinder head gasket on block and carefully install cylinder head, making sure any valves in open position do not contact block.

4) Install a few head bolts and tighten manually and remove dummy studs. Install remaining head bolts and tighten to specification in sequence shown in illustration.

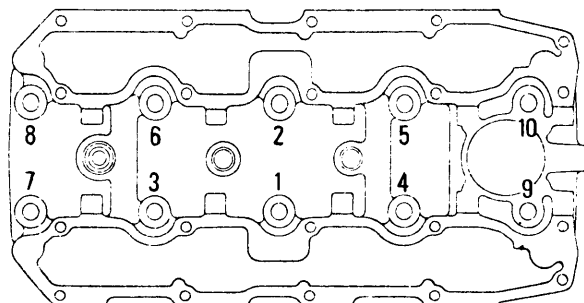

Fig. 1 Cylinder Head Tightening Sequence

Fiat Engines

124 & 131 4 CYLINDER (Cont.)

VALVES							
Engine & Valve	Head Diam. In. (mm)	Face Angle	Seat Angle	Seat Width In. (mm)	Stem Diameter In. (mm)	Stem Clearance In. (mm)	Valve Lift In. (mm)
1756 cc Int.	1.622-1.638 (41.2-41.6)	45°	45°	.079 (2.0)	.3139-.3146 (7.974-7.992)	.0012-.0026 (.030-.066)	.3765 (9.564)
Exh.	1.412-1.435 (35.85-36.45)	45°	45°	.079 (2.0)	.3139-.3146 (7.974-7.992)	.0012-.0026 (.030-.066)	.3765 (9.564)

VALVE ARRANGEMENT

Left Side — All Intake
Right Side — All Exhaust

VALVE GUIDE SERVICING

1) Measure clearance of valve stem in guide with a dial indicator. If clearance exceeds specifications, valve guide must be replaced.

2) Drive guide out of head from combustion chamber side through top of head. Drive new guide in from top of head. Install new guide with snap ring flush against head.

VALVE SPRINGS			
Engine	Free Length In. (mm)	PRESSURE Lbs. @ In. (kg @ mm)	
		Valve Closed	Valve Open
1756 cc Inner Spring	1.646 (41.8)	33@1.220 (14.9@31)	62@.846 (28.1@21.5)
Outer Spring	2.122 (53.9)	86@1.417 (38.9@36)	131@1.043 (59.5@26.5)

VALVE SPRING REMOVAL

1) With cylinder head removed, remove camshaft carriers with camshafts. Compress valve spring with a spring compressor and remove both valve keepers.

2) Release spring compressor, remove upper spring retainer, inner and outer springs and lower spring retainer. To assemble cylinder head, reverse disassembly procedure.

VALVE CLEARANCE ADJUSTMENT

1) Valve clearance is checked and/or adjusted with engine cold. Intake valve clearance is .018" (.457 mm). Exhaust valve clearance is .020" (.508 mm).

2) To adjust valves, remove camshaft covers from cylinder head. Rotate crankshaft until camshaft lobe of valve being adjusted is pointing away from valve (valve will be closed).

3) Using a feeler gauge, measure valve clearance. If clearance is not as specified, a thicker or thinner tappet plate must be installed to obtain specified clearance.

4) Tappet plates are available in service thicknesses of .128" (3.25 mm) and from .130" to .185" (3.30 mm to 4.70 mm) in increments of .004" (.10 mm).

5) To replace tappet plate, rotate camshaft until valve is fully open. Insert a suitable tappet hold down tool (A.60318) over lobe of valve being adjusted. Rotate camshaft and remove tappet plate by means of scribe through notch in tappet. Alternately, tappet may be pried down using suitable pry tool (A.60443) and tappet plate may then be removed using scribe.

6) Insert correct thickness tappet plate, rotate camshaft until lobe is resting on tappet plate and remove tool. Use this same procedure for adjusting both intake and exhaust valve clearances.

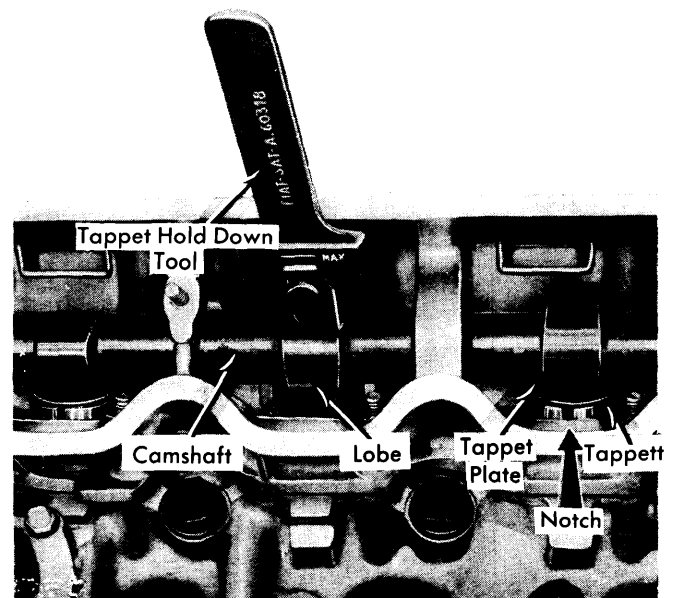

Fig. 2 Correct Procedure to Adjust Valve Clearance

124 & 131 4 CYLINDER (Cont.)

PISTONS, PINS, RINGS						
Engine	PISTONS Clearance In. (mm)	PINS		RINGS		
		Piston Fit In. (mm)	Rod Fit In. (mm)	Rings	End Gap In. (mm)	Side Clearance In. (mm)
1756 cc	.0016-.0024 (.040-.060)	.0001-.0003 (.002-.008)	.0004-.0006 (.010-.016)	No. 1	.0118-.0177 (.30-.45)	.0018-.0030 (.045-.077)
				No. 2	.0078-.0139 (.20-.35)	.0011-.0027 (.030-.070)
				Oil	.0078-.0139 (.20-.35)	.0011-.0024 (.030-.062)

OIL PAN REMOVAL

- 1) Raise vehicle and drain crankcase. Disconnect front motor mounts and raise engine enough to remove oil pan.
- 2) To install, clean all mating surfaces thoroughly and install a new gasket with sealer. Reverse removal procedure and tighten bolts to specification.

PISTON & ROD ASSEMBLY

- 1) When installing piston and rod assembly, thoroughly oil piston pin in piston boss. Make sure ring gaps are spaced approximately 120° apart.
- 2) Lubricate rings and cylinder bore. Compress rings with a ring compressor and install assembly in cylinder block so that numbers on connecting rod and cap are facing away from auxiliary shaft. Tighten connecting rod nuts to specification.

FITTING PISTONS

- 1) Standard pistons are manufactured in three size classes and cylinder bores are machined according to piston class. Class of piston and bore is designated by a letter code.
- 2) Class code of piston is stamped on bottom of piston pin boss. Class of cylinder bore is stamped next to appropriate cylinder on oil pan flange on bottom of cylinder block.
- 3) Measure piston size at right angle to piston pin and 1.876 (47.65 mm) below piston head. If piston is replaced for any reason, one of the same class must be installed. **NOTE** — Refer to class designation on cylinder block (see Fig. 4).

Std. Piston Class Designation & Size

Class	In. (mm)
A.....	3.3051-3.3055 (83.95-83.96)
C.....	3.3059-3.3063 (83.97-83.98)
E.....	3.3066-3.3070 (83.99-84.00)

- 4) With piston size determined, measure cylinder bore. If clearance exceeds specification, cylinders must be rebored and oversize pistons installed.

Oversize Pistons

Application	Amt. of Oversize In. (mm)
1st Oversize0079 (0.2)
2nd Oversize0157 (0.4)
3rd Oversize0236 (0.6)

NOTE — If replacement pistons are used, ensure that the four pistons are the same weight within $\pm .18$ oz. (± 5 g).

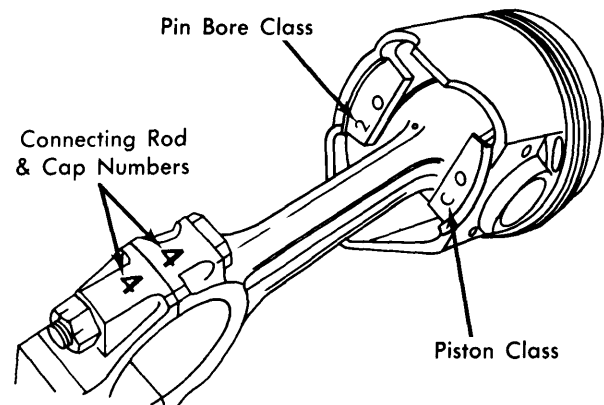

Fig. 3 Piston & Rod Assembly Markings

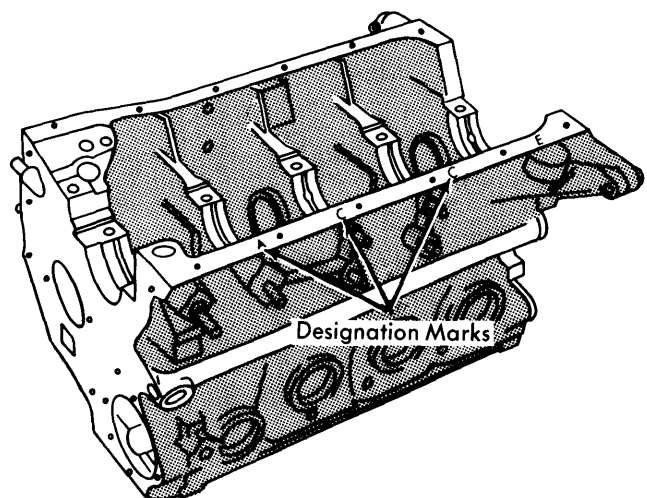

Fig. 4 Piston Bore Class Designation Marks

124 & 131 4 CYLINDER (Cont.)

PISTON PIN REPLACEMENT

1) Remove circlips from piston and push piston pin out of piston and connecting rod. Separate piston from connecting rod.

2) Check clearance of piston pin in piston and connecting rod. If clearance is excessive, piston and connecting rod must be rebored for a .0079" (.2 mm) oversize pin.

3) Bushing in small end of connecting rod is replaceable and requires a .0017-.0040" (.043-.102 mm) interference fit.

4) To assemble piston and rod assembly, position piston on connecting rod with side of piston having offset portion of piston pin bore on same side as connecting rod numbers.

5) Oil piston pin and insert in piston and connecting rod. Install circlips and check piston for freedom of movement on pin. Check alignment.

CRANKSHAFT MAIN & CONNECTING ROD BEARINGS

Engine	MAIN BEARINGS				CONNECTING ROD BEARINGS		
	Journal Diam. In. (mm)	Clearance In. (mm)	Thrust Bearing	Crankshaft End Play In. (mm)	Journal Diam. ① In. (mm)	Clearance ② In. (mm)	Side Play In. (mm)
1756 cc	2.0860-2.0868 (52.99-53.00)	.0020-.0037 (.050-.095)	No. 5	.002-.012 (.05-.30)	1.9997-2.0001 (50.79-50.80)	.0018-.0031 (.045-.079)

① — Journal diameter is machined in two sizes designated by class codes. Specification given is class "A". Class "B" is smaller by .0004" (.010 mm).

② — Clearance varies according to class of connecting rod journal. Specification given is class "A". Class "B" clearance is larger by .0001" (.002 mm).

MAIN & CONNECTING ROD BEARINGS

NOTE — On late production models, modified main and connecting rod bearings have been installed. New clearances are; Main bearings .0015-.0025" (.032-.067 mm), Connecting rod bearings .0014-.0024" (.031-.065 mm). Modified bearings can be installed in earlier engines, however bearing clearances must meet new specifications.

1) With crankshaft removed, thoroughly clean and inspect for cracks or scoring on journals. Check all journals for out-of-round condition, using a micrometer. If journal is out-of-round or tapers more than .0002" (.005 mm), crankshaft must be reground for undersize bearings.

2) Bearing-to-journal clearance is checked by the Plastigage method. If clearance exceeds specifications, crankshaft must be ground for undersize bearings.

3) Main and connecting rod bearings are available in .010" (.25 mm), .020" (.51 mm), .030" (.76 mm), and .040" (1.02 mm) undersizes.

CRANKSHAFT END PLAY

1) Mount a dial indicator on front of engine and pry crankshaft back and forth to measure crankshaft end play.

2) If end play exceeds specifications, adjustment may be made by installing new thrust washers to bring end play within specification.

ENGINE FRONT COVER & OIL SEAL

Engine front cover oil seal should be replaced whenever front cover is removed. Make sure new seal is squarely seated in cover. Lubricate seal contact lip before installing cover.

TIMING BELT REPLACEMENT

1) Drain cooling system and remove upper radiator hose. Remove upper section of air duct. Rotate crankshaft until marks on both camshaft sprockets are aligned with fixed pointer on front of engine. Number 4 piston should now be at TDC firing position.

2) Place transmission in fourth gear and apply parking brake to prevent crankshaft from turning. **CAUTION** — Do not turn crankshaft or camshafts independent of each other as valves may hit pistons.

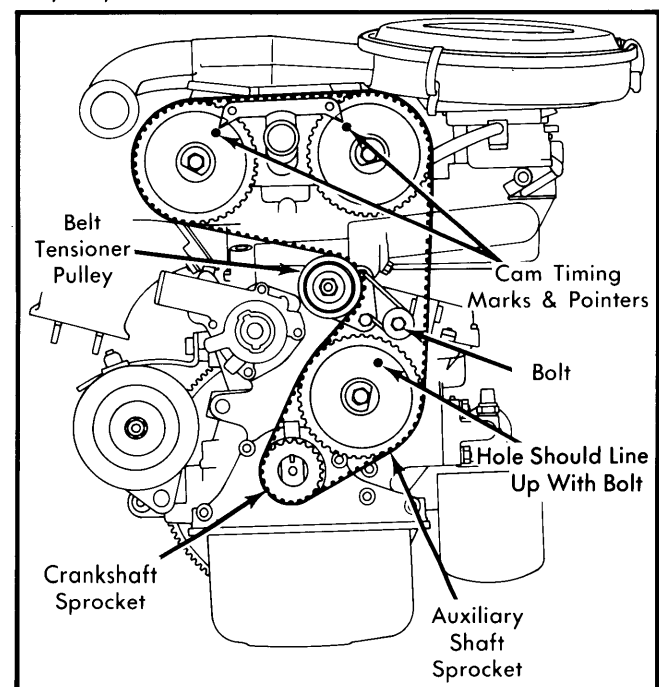

Fig. 5 Camshaft Sprocket Timing Marks

124 & 131 4 CYLINDER (Cont.)

3) Remove lower engine protection plate and all drive belts. Loosen belt idler pulley nut and mounting bracket bolt, release tension on timing belt, tighten pulley nut and bracket bolt and remove belt. **NOTE** — Anytime tension is relieved from timing belt, it must be replaced. Install belt making sure not to move sprockets. Make sure that hole in auxiliary shaft pulley is lined up with tensioner pulley bolt.

4) To adjust timing belt tension loosen belt idler pulley nut and bracket mounting bolt. Spring will adjust tension. Tighten idler pulley nut and bracket bolt. Check belt tension two or three times, rotating crankshaft $\frac{1}{2}$ to $\frac{3}{4}$ turns between checks.

VALVE TIMING				
Engine	INTAKE		EXHAUST	
	Open (BTDC)	Close (ALDC)	Open (BLDC)	Close (ATDC)
1756 cc	5°	53°	53°	5°

CAMSHAFT

1) Remove front cover, drive belts, and timing belt. Remove carburetor, intake manifold, distributor, exhaust manifold and cam covers. Remove air pump support bracket and air pump. Remove front cam housing bolts and install special tool (A.60446) to remove camshaft pulleys.

2) Remove camshaft housings and gaskets from crankcase. Remove end plates from housings. Slide camshafts out of housings. To install, reverse removal procedure.

CAMSHAFT			
Engine	Journal Diam. In. (mm)	Clearance In. (mm)	Lobe Lift In. (mm)
1756 cc Front	1.1788-1.1795 (29.94-29.96)	.0019-.0035 (.049-.090)	.3824 (9.71)
	Middle	1.8013-1.8020 (45.75-45.77)	.0011-.0027 (.029-.070)
Rear	1.8171-1.8178 (46.15-46.17)	.0011-.0027 (.029-.070)	.3824 (9.71)

AUXILIARY SHAFT

Auxiliary shaft drives: distributor, oil pump and fuel pump. Shaft is driven by timing belt. Remove oil pump. See *Oil Pump Removal*. Remove fuel pump and distributor. Remove front cover and timing belt. Remove auxiliary shaft sprocket. Remove retainer plate and shaft from crankcase. To install, reverse removal procedure.

ENGINE OILING

Crankcase Capacity — Total capacity including filter, oil lines, etc. is 4.5 qts. Normal drain and refill capacity (including filter change) is 4 qts.

Oil Filter — Full-flow, cartridge type.

Normal Oil Pressure — 64-85 psi (4.5-6 kg/cm²) at idle.

Pressure Regulator Valve — Installed in pump cover.

ENGINE OILING SYSTEM

Engine oiling system is full pressure lubrication utilizing a gear type oil pump driven by auxiliary shaft. A full-flow oil filter and a pressure regulator valve is also employed.

OIL PUMP

1) To remove oil pump, drain oil and remove oil pan. Remove two bolts and washers holding oil pump to engine and remove pump and gasket. Visually inspect all parts for wear or damage.

2) Check gears for tooth-to-housing clearance. Clearance should be .004-.007" (.11-.18 mm). Place straightedge across

pump body and measure gear end play. End play should be .0012-.0045" (.031-.116 mm). Replace parts as necessary, reassemble and reinstall oil pump using new gaskets.

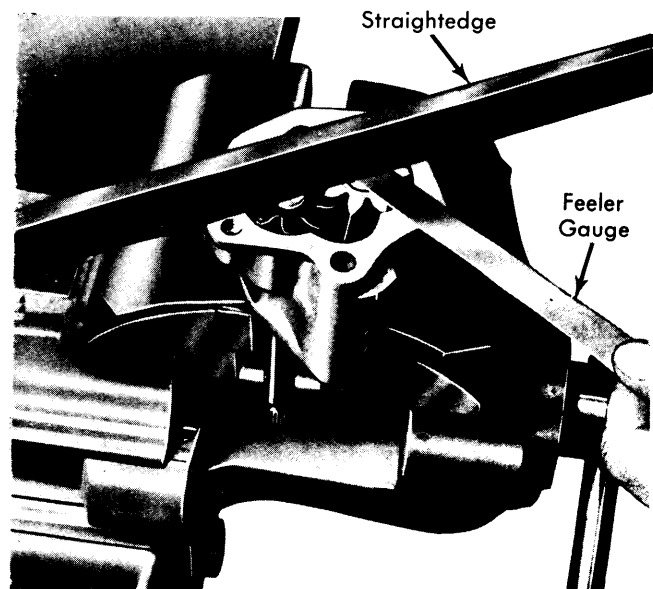

Fig. 6 Checking Oil Pump Gear End Play

Fiat Engines

124 & 131 4 CYLINDER (Cont.)

ENGINE COOLING

Thermostat Opening Temperature - 178-185°F (81-85°C).

Cooling System Capacity - 8.5 qts.

WATER PUMP

To remove water pump, remove alternator and drive belt. Disconnect water hoses from pump and remove three bolts securing pulley on pump. Remove four bolts securing pump to engine and remove pump and gasket. To install, reverse removal procedure and use new gasket.

TIGHTENING SPECIFICATIONS

Application	Ft. Lbs. (mkg)
Cylinder Head Bolts	54 (7.5)
Front Main Bearing Cap Bolts	58 (8.0)
Main Bearing Cap Self-Locking Bolts	83 (11.5)
Intake & Exhaust Manifold Nuts	18 (2.5)
Connecting Rod Nuts	47 (6.5)
Flywheel-to-Crankshaft Bolt	62 (8.5)
Camshaft Sprocket Bolt	87 (12)
Tensioner Nut	33 (4.6)