

280Z 6 CYLINDER

GENERAL SPECIFICATIONS										
Year	Displ.		Carburetor	HP at RPM	Torque (Ft. Lbs. at RPM)	Compr. Ratio	Bore		Stroke	
	cu. ins.	cc					in.	mm	in.	mm
1976	168.0	2753	Fuel Inj.	8.3-1	3.390	86	3.110	79

ENGINE IDENTIFICATION

Engine serial number is stamped on right rear side of cylinder block where cylinder head contacts block. Number is preceded by engine model designation, L28.

ENGINE REMOVAL

NOTE — It is recommended that engine and transmission be removed as a unit. Engine can then be separated from transmission assembly.

- 1) Fuel hose pressure must be decreased to zero as follows before attempting engine removal. Disconnect battery ground cable, ground lead wire (black) from fuel pump, and lead wire from "S" terminal of starter. Remove cold start valve attaching bolts and valve. Connect a ground cable to battery. Place cold start valve in a container, turn ignition switch to "START" position, and release fuel hose pressure.
- 2) Scribe alignment marks around hood hinges and remove hood. Drain cooling system and engine crankcase. Disconnect battery cables. Remove radiator hoses. Remove air flow meter and air duct clamps with rubber hoses. Remove air cleaner and disconnect hoses from canister, then remove canister. Disconnect transmission cooler lines (automatic transmission models), and remove radiator and shroud.
- 3) Disconnect accelerator linkage. Disconnect the wiring to starter, alternator, oil pressure switch, neutral switch, back-up lamp switch, EGR solenoid valve, electric fuel injector, throttle valve switch, cold start valve, air regulator, vacuum cutting solenoid (manual transmission models), and all wiring to thermostat housing.
- 4) Disconnect wiring to boost controlled deceleration solenoid valve. Disconnect engine ground cable to engine, and high tension cable between coil and distributor. Disconnect wire for block terminal. Disconnect fuel return hose and fuel charge hose, heater hoses, and all vacuum hoses. On models with automatic transmission, disconnect wire to inhibitor switch and downshift solenoid.
- 5) Remove clutch operating cylinder on models with manual transmission. Disconnect speedometer cable from rear extension housing. Remove center console, "C" ring, and control lever pin from transmission striking rod guide, then remove control lever on models with manual transmission. On models with automatic transmission, disconnect shift control lever.
- 6) Disconnect exhaust pipe from exhaust manifold. Disconnect exhaust pipe bracket from rear extension housing and tie exhaust pipe out of the way. Mark propeller shaft and pinion flange to aid in reassembly, then remove propeller shaft from vehicle. Plug rear of extension housing to prevent oil leakage.

Support transmission with a jack and remove rear engine mount. Use a hoist to raise engine and remove front engine mount attaching bolts. Raise engine and transmission and remove from vehicle as a unit.

CYLINDER HEAD

Removal — 1) Drain cooling system and disconnect upper radiator hose and heater hoses. Dissipate fuel hose pressure to zero. See step 1) under Engine Removal. Remove air regulator and all connecting hoses as an assembly. Remove spark plug wires at plug end. Remove EGR control valve, vacuum switching valve and hoses as an assembly. Remove throttle chamber with dash pot and boost controlled deceleration device.

2) Remove fuel lines, vacuum hoses, and canister purge hose pressure regulator. **NOTE** — Remove clip attaching fuel inlet hose to injector and take care not to twist or bend fuel inlet hose during removal. Remove thermostat housing and all attached switches as an assembly. Remove PCV valve hose, sub-heat shield plate, and EGR tube.

3) Remove intake manifold and heat shield plate. Remove exhaust manifold. Remove all drive belts. Remove camshaft sprocket attaching bolt and remove sprocket from timing chain. **NOTE** — Use special tool ST17420001 to support timing chain so timing marks on crankshaft sprocket and timing chain will remain unchanged to simplify timing mark alignment upon reassembly. Remove oil pipe. Remove cylinder head attaching bolts working from the ends towards center of cylinder head. Remove cylinder head from engine block.

Installation — With cylinder head and block surface clean, install cylinder head gasket. **NOTE** — Do not use sealer on gasket or head surfaces. Install cylinder head and attaching bolts. Tighten cylinder head bolts in three steps using sequence indicated in illustration. Install camshaft sprocket and attaching bolt while making sure timing chain has not moved from its original position. Install remaining components in reverse of removal procedure, and tighten all nuts and bolts.

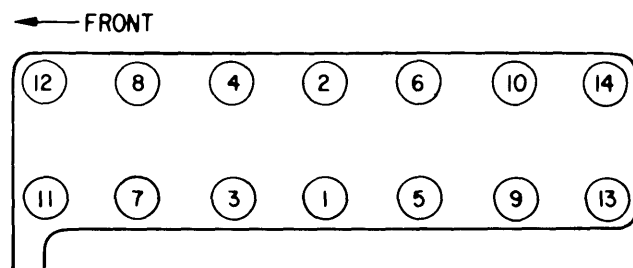

Fig. 1 Cylinder Head Tightening Sequence

Datsun Engines

280Z 6 CYLINDER (Cont.)

VALVES							
Engine & Valve	Head Diam. In. (mm)	Face Angle	Seat Angle	Seat Width In. (mm)	Stem Diameter In. (mm)	Stem Clearance In. (mm)	Valve Lift In. (mm)
L28 Int.	1.73 (44.0)	45.5°	45°	.055-.063 (1.4-1.6)	.3136-.3142 (7.965-7.980)	.0008-.0021 (.020-.053)	.433 (11)
Exh.	1.38 (35.0)	45.5°	45°	.071-.087 (1.8-2.2)	.3128-.3134 (7.945-7.960)	.0016-.0029 (.040-.073)	.433 (11)

VALVE ARRANGEMENT

E-I-I-E-I-E-E-I-E-I-E (front to rear).

VALVE GUIDES CHECKING

1) Measure clearance between valve stem and valve guide with aid of micrometer and hole gauge. Check diameter of valve stem in three places: top, center and bottom.

2) Insert hole gauge in valve guide bore and measure at center. Subtract highest reading of valve stem diameter from valve guide bore to obtain clearance.

NOTE — As a quick check, a valve may be inserted into valve guide and moved either left or right (parallel with rocker arm). If its tip moves about .0079" or more, the clearance is beyond maximum limit of .0039".

VALVE GUIDE REPLACEMENT

1) Using a press and drift pin, force worn guide from cylinder head working from combustion cylinder side. Although this procedure may be carried out at room temperature, higher temperatures will aid removal.

2) Ream cylinder head side guide hole to provide interference fit of .0011-.0019" (.027-.049 mm). Press new valve guide into cylinder head so that it will fit smoothly when cylinder head is heated to 302-392°F (150-200°C).

3) Ream bore of valve guides to .3150-.3157" (8.000-8.018 mm). Correct valve seat surface using new valve guide as axis.

VALVE SEAT INSERTS

Check valve seats for pitting at valve contact surface. Valve seat inserts of .020" (.5 mm) oversize are available if necessary.

VALVE STEM OIL SEALS

An oil seal is installed on all intake and exhaust valve stems inside of valve spring.

VALVE SPRINGS			
Engine	Free Length In. (mm)	PRESSURE Lbs. @ In. (kg @ mm)	
		Valve Closed	Valve Open
L28 Inner	1.76 (44.85)	27.12@1.38 (12.3@35.0)	56.22@.965 (25.5@24.5)
Outer	1.97 (49.98)	46.96@1.57 (21.3@40.0)	108.03@1.16 (49.0@29.5)

VALVE SPRINGS

Removal — With cylinder head removed, loosen pivot lock nut and remove rocker arm by pressing valve spring down, taking care not to lose valve rocker guide. Remove camshaft taking care not to damage camshaft bearings and cam lobes. Compress valves and remove valve keepers. Remove compressing tool, then remove spring retainer, inner and outer springs, oil seal and valve spring seat.

Installation — Install spring seat and fit oil seal onto valve guide. Install inner and outer valve springs, spring retainer, valve keepers and rocker guide. **NOTE** — Outer spring must be installed with painted side toward cylinder head. Install camshaft to cylinder head. Press valve springs down using a screwdriver and install rocker arms. Install valve rocker springs.

VALVE SPRING INSTALLED HEIGHT

Valve spring must be square within $\frac{1}{16}$ ". Valve spring installed height is 1.38" (35 mm) for inner spring and 1.57" (40 mm) for outer spring. If spring height and pressure, or squareness does not meet specifications, replace spring.

VALVE ADJUSTMENT

Loosen pivot locking nut and turn pivot screw until specified clearance is obtained with engine cold. Tighten pivot locking nut after adjustment and recheck clearance. Warm up engine. With engine stopped, measure valve clearance and reset to hot clearances if necessary.

Valve Adjustment Clearances

Valve	Hot	Cold
Intake010"(.25 mm)	.008"(.20 mm)
Exhaust012"(.30 mm)	.010"(.25 mm)

280Z 6 CYLINDER (Cont.)

PISTONS, PINS, RINGS						
Engine	PISTONS	PINS		RINGS		
	Clearance In. (mm)	Piston Fit In. (mm)	Rod Fit In. (mm)	Rings	End Gap In. (mm)	Side Clearance In. (mm)
L28	.0010-.0018 (.025-.045)	.0002-.0051 (.006-.013)	① .0006-.0013 (.015-.033)	No. 1	.009-.015 (.23-.38)	.0018-.0031 (.045-.080)
				No. 2	.006-.012 (.15-.30)	.0012-.0028 (.030-.070)
				Oil	.006-.012 (.15-.30)	Snug

① — Interference fit.

PISTON & ROD ASSEMBLY

1) Remove cylinder head and oil pan. Remove nuts from connecting rod and remove connecting rod cap with bearing half. Push piston and connecting rod assembly with bearing half up and out through top of crankcase. **NOTE** — Keep connecting rod caps with their respective piston and rod assembly as caps are not interchangeable.

2) To install piston and connecting rod assembly, thoroughly oil rings, piston and cylinder wall. Make sure ring gaps are situated approximately 180° apart and not on thrust side of piston or in line with piston pin. Make sure bearing halves are properly seated in connecting rod and cap.

3) Install a ring compressor and compress rings. Install piston in cylinder with notch mark on piston head toward front of engine. With piston installed in cylinder, and connecting rod and bearings seated against crankshaft journal, install rod caps to their respective piston and rod assembly. Oil jet of connecting rod should face right side of cylinder block. Install cylinder head and oil pan.

FITTING PISTONS

1) Visually inspect cylinder block for cracks or flaws. Using a suitable bore gauge, measure cylinder for out-of-round or taper. If cylinder bore out-of-round or taper exceeds .0006" (.015 mm), refinish cylinder bore. When any one cylinder is bored, all cylinders must be bored.

2) Determine piston oversize according to amount of wear in cylinder (see specifications). By measuring piston at thrust face and adding mean of piston-to-cylinder clearance, finish hone of cylinder may be determined.

3) After honing cylinder to final fit, measure piston-to-cylinder clearance using pull scale and feeler gauge. Extracting force to pull scale should be .44-3.31 lbs. (.2-1.5 kg) using a .0016" (.04 mm) feeler gauge. If cylinder bores are worn beyond limits, undersize cylinder liners are available. Liners should have an interference fit of .0031-.0035" (.08-.09 mm) in cylinder block.

Piston Specifications

Piston Size In. (mm)	Piston Diameter In. (mm)
Standard	3.3852-3.3872(85.985-86.035)
.020 (.50) O/S	3.4041-3.4061(86.465-86.515)
.040 (1.0) O/S	3.4238-3.4258(86.965-87.015)

PISTON PINS

Using suitable press and related adaptors, remove piston pin from piston and connecting rod. Measure pin bore diameter in piston and connecting rod. If wear exceeds specifications, replace both piston and pin. Pin must fit piston with light thumb pressure at room temperature. Piston pin is a press fit (interference) in connecting rod. If connecting rod is replaced, insure that new rod is within .247 ounce (7 grams) of the defective connecting rod. Install piston pin to piston and connecting rod so oil hole on connecting rod will face right side of engine and notch on piston head will face forward when assembly is installed.

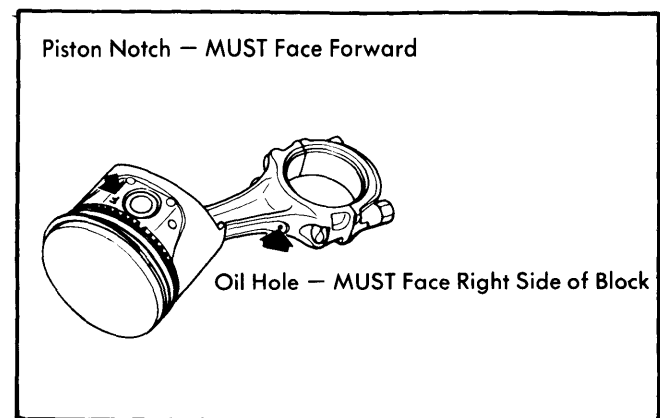

Fig. 2 Piston and Connecting Rod Alignment

CRANKSHAFT MAIN & CONNECTING ROD BEARINGS							
Engine	MAIN BEARINGS				CONNECTING ROD BEARINGS		
	Journal Diam. In. (mm)	Clearance In. (mm)	Thrust Bearing	Crankshaft End Play In. (mm)	Journal Diam. In. (mm)	Clearance In. (mm)	Side Play In. (mm)
L28	2.1631-2.1636 (54.942-54.955)	.0008-.0028 (.202-.071)	Center	.002-.007① (.05-.18)	1.9670-1.9675 (49.961-49.974)	.0010-.0022 (.025-.056)	.0079-.0118 (.20-.30)

① — Wear limit is .0118" (.3 mm).

280Z 6 CYLINDER (Cont.)

CRANKSHAFT

Removal — With engine removed from vehicle, remove cylinder head and oil pan. Remove flywheel and end plate. Remove oil pump, front cover, chain tensioner and chain guides. Remove timing chain, oil thrower, crankshaft worm gear, and chain drive sprocket. Remove piston and rod assemblies. Remove main bearing caps using a special puller (ST1651S000) to remove center and rear main bearing caps.

NOTE — Keep all main bearing caps in order to aid in reassembly. Remove rear oil seal, then remove crankshaft.

Inspection — Check shaft journals and crankpins for scoring, wear, or cracks. Taper and out-of-round of journals and crankpins must not exceed .0012" (.03 mm). Check crankshaft for bend using a dial indicator at center journal of crankshaft. If bend exceeds .004" (.10 mm), which is one-half of indicator reading, replace crankshaft. Check main drive shaft pilot bearing at rear of crankshaft for wear or damage and replace if necessary.

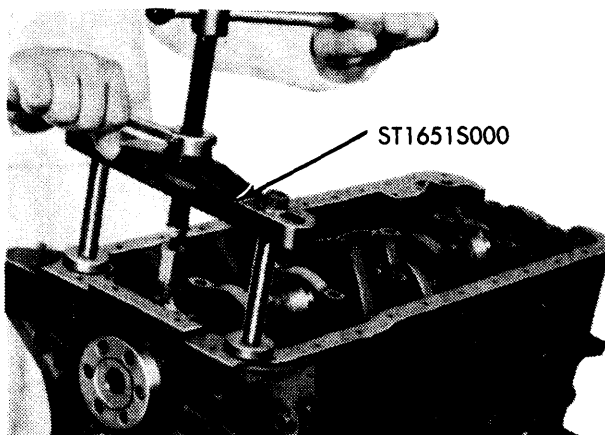

Fig. 3 Rear Main Bearing Cap Removal

Installation — 1) Install main bearing halves to engine block ensuring that all bearings are on correct journal. Journal No. 4 requires a thrust bearing. Bearing for journal No. 1 is the same as for journal No. 7. Upper and lower bearings are not interchangeable.

2) Apply oil to main bearing surface and install crankshaft. Install main bearing caps with arrow pointing toward front of engine. **NOTE** — Apply sealer to main bearing caps at point where cap contacts cylinder block. Shift crankshaft toward front of engine, then tighten main bearing caps, in two or three steps, starting at center bearing and working outwards. Ensure crankshaft rotates smoothly.

3) Check crankshaft end play, and if not within specifications, replace center thrust bearing. Install side seals in rear main bearing cap after applying sealer to seals. Install rear oil seal. Install rear end plate and flywheel. Install piston and rod assemblies. Install cylinder head, crankshaft sprocket, worm gear, chain drive sprocket, oil thrower, and timing chain. Install chain guides and tensioner, front cover, oil pump and oil pan. Install remaining components in reverse of removal procedure.

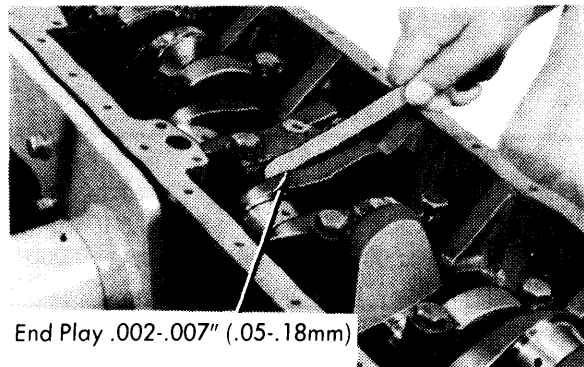

Fig. 4 Measuring End Play at No. 4 Main Bearing

MAIN BEARING CLEARANCE

1) Check all bearings for scoring or wear and replace if damage is found. Clean oil from crankshaft and place a strip of Plastigage on crankshaft journal. **NOTE** — Plastigage should run parallel with crankshaft journal and should not block oil hole. Install main bearing cap, with bearing installed, and tighten to 33-40 ft. lbs. (4.5-5.5 mkg). **NOTE** — Do not turn crankshaft while Plastigage is inserted.

2) Remove cap and measure width of Plastigage at widest point using gauge provided with Plastigage. If clearance is not to specifications, replace bearings. Bearings are available in undersizes of .01" (.25 mm), .02" (.50 mm), .03" (.75 mm), and .04" (1.0 mm).

3) Bearings are manufactured with crush to cause bearing to snug down into bore. To measure, set bearing in cap or cylinder block and lock one side end of bearing. Press other side of bearing until back surface touches bore. Measure bearing crush, as shown in illustration, using a feeler gauge. Measurement must be 0-.0012" (0-.03 mm).

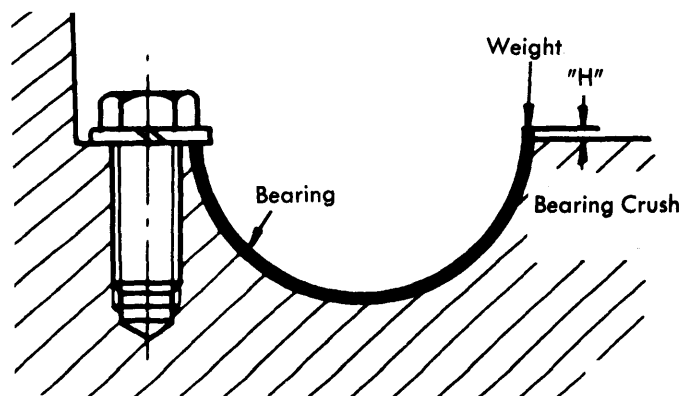

Fig. 5 Measuring Bearing Crush in Cylinder Block

CONNECTING ROD BEARING CLEARANCE

Check connecting rod bearing clearance in same manner as main bearing clearance using Plastigage. Tighten connecting rod caps to 33-40 ft. lbs. (4.5-5.5 mkg). Bearings are available in undersizes of .0024" (.06 mm), .005" (.12 mm),

280Z 6 CYLINDER (Cont.)

.01" (.25 mm), .02" (.50 mm), .03" (.75 mm), and .04" (1.0 mm). Check bearing crush of connecting rod bearings in same manner as for main bearings. Clearance must be .0006-.0018" (.015-.045 mm).

ENGINE FRONT COVER

Removal — Drain cooling system, disconnect hoses and remove radiator. Remove all drive belts, fan blade and pulley. Disconnect all wiring and connections to thermostat housing and remove housing. Remove crankshaft pulley and water pump. Remove spark plug wires from plugs, mark position of distributor base to engine and position of rotor to distributor. Disconnect distributor wires from coil and remove distributor. Remove oil pump with its drive spindle. Remove front cover attaching bolts and front cover.

Installation — Apply sealer to four corners of front cover and gasket, then install cover onto cylinder block. Tighten front cover attaching bolts. Install oil pump with drive spindle. Install distributor while aligning matching marks. Reconnect spark plug wires and all distributor connections. Install water pump and crankshaft pulley. Install thermostat housing and reconnect all wiring. Install fan blade and pulley. Install drive belts, radiator, hoses, and fill cooling system.

CAMSHAFT			
Engine	Journal Diam. In. (mm)	Clearance In. (mm)	Lobe Lift In. (mm)
L28	1.88770-1.8883 (47.947-47.962)	.0015-.0026 (.038-.067)	.275 (7.0)

CAMSHAFT

Removal — Remove cylinder head. Remove valve rocker springs. Loosen valve rocker pivot lock nuts and remove rocker arms by pressing down on spring. Use care not to lose valve rocker guide. Carefully remove camshaft from front of cylinder head.

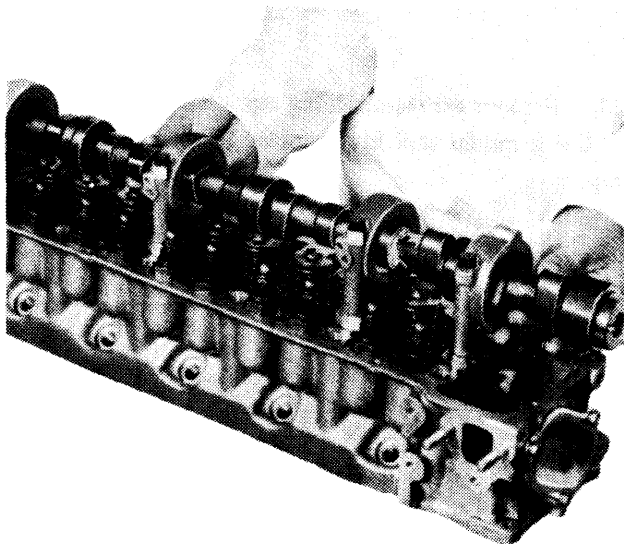

Fig. 6 Withdrawing Camshaft From Cylinder Head

Installation — Carefully install camshaft into cylinder head taking care not to damage bearings. Install camshaft locating plate with oblong groove of plate facing front of cylinder head. Install camshaft sprocket and tighten attaching bolt. Install remaining components in reverse of removal procedure, and tighten all nuts and bolts.

CAMSHAFT BEARINGS

NOTE — Do not remove camshaft bearings. If bearings are removed, bearing centers will be out of alignment and proper reassembly will be difficult without center boring.

Measure inner diameter of camshaft bearing and outer diameter of camshaft journal. If wear or damage is excessive, replace cylinder head assembly.

TIMING CHAIN

Removal — Remove engine front cover. Remove camshaft drive sprocket, timing chain, tensioner and chain guide. Remove oil thrower, crankshaft worm gear, and crankshaft sprocket.

Installation — Install components in reverse of removal procedure while noting the following: When installing timing chain, camshaft sprocket or crankshaft sprocket, make sure camshaft and crankshaft keys point upward. Set timing chain so that its mating marks match marks on crankshaft and camshaft sprockets on right-hand side. There are 42 chain links between the two timing chain marks. Factory setting of camshaft sprocket is number one hole, if chain is excessively stretched use number two or three hole to achieve correct valve timing.

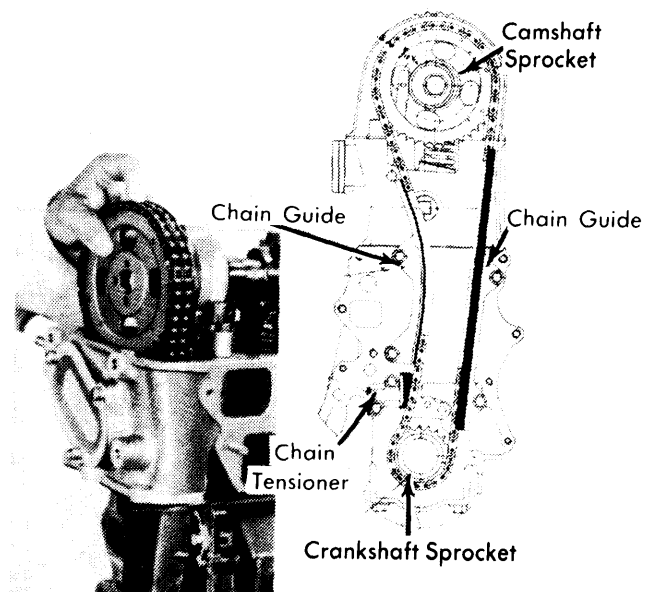

Fig. 7 Timing Chain & Sprocket Installation

Datsun Engines

280Z 6 CYLINDER (Cont.)

ENGINE OILING

ENGINE OILING SYSTEM

Oil drawn from oil pan passes through a screen to oil pump. Oil is delivered to full flow oil filter and to main oil gallery. Main oil gallery supplies oil to crankshaft main bearings and drilled passages in crankshaft. Oil sprayed from jet holes on connecting rods lubricates cylinders and piston pins. Oil from main gallery lubricates chain tensioner and timing chain. A center oil hole in the crankshaft center bearing feeds camshaft bearings on cylinder head. Valve rocker mechanism is lubricated through oil gallery in camshaft and through a small channel at base circle portion of each cam. Rocker arms and valves are lubricated intermittently through small holes or oil pipe.

Crankcase Capacity – 5 qts. including filter change.

Oil Filter – Full-flow, with disposable cartridge.

Oil Pressure – 50-57 psi (3.5-4.0 kg/cm²) @ 2000 RPM.

OIL PUMP

Oil pump assembly is installed to bottom of front cover by four bolts. Pump is driven by oil pump drive spindle assembly which is in turn driven by gear on crankshaft. To remove oil pump, first remove distributor. Drain engine oil and remove oil pump body together with drive spindle. To disassemble, proceed as follows:

1) Remove pump cover and gasket. Slide pump rotors from pump body. Remove regulator cap, valve and spring. Clean all components with cleaning solvent, and inspect for wear or damage. Check the clearances indicated in the following table

and ensure clearances are to specifications. If components are not to specifications, replace entire pump assembly.

2) Assemble pump in reverse of disassembly while making sure mark dotted on rotors faces oil pump body. Fill pump housing with engine oil before installing to front cover.

Oil Pump Specifications	
Application	Clearance In. (mm)
Inner-to-Outer Rotor	
Side Clearance.....	.0016-.0032"(.04-.08 mm)
Rotor Tip Clearance.....	Less Than .0047 (.12)
Outer Rotor-to-Body0059-.0083 (.15-.21)
Rotor-to-Cover.....	.0012-.0051 (.03-.13)

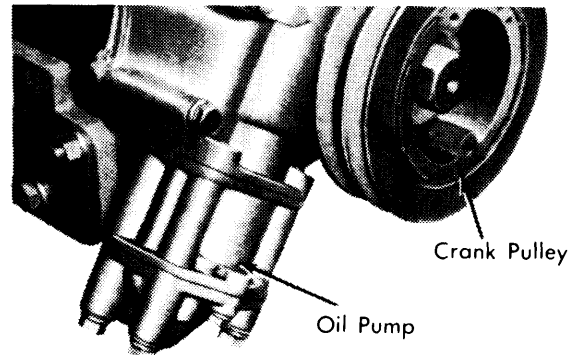

Fig. 9 Location of Oil Pump Assembly

ENGINE COOLING

WATER PUMP

Centrifugal type pump with aluminum body. To remove, drain cooling system and remove fan shroud. Remove fan belts, fan, and pulley. Remove pump attaching bolts and remove water pump from front cover.

Thermostat – Opens at 180°F (82°C).

Cooling System Capacity – 10 qts.

Radiator Cap – 13 psi.

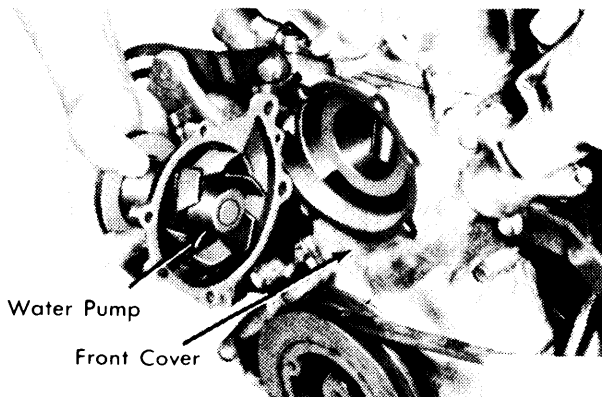

Fig. 10 Installing Water Pump to Front Cover

TIGHTENING SPECIFICATIONS	
Application	Ft. Lbs.(mkg)
Cylinder Head	
Step One	29(4.0)
Step Two	47(6.5)
Step Three	54-61(7.5-8.5)
Connecting Rod	33-40(4.5-5.5)
Flywheel	94-108(13-15)
Camshaft Gear	94-108(13-15)
Oil Pan	4.3-7.2(.6-1.0)
Oil Pump-to-Front Cover	8-11(1.1-2.1)
Oil Pump Cover	5-7(.7-1.0)
Camshaft Lock Plate	3.6-5.8(.5-.8)
Crankshaft Pulley	94-108(13-15)
Main Bearing Cap	33-40(4.5-5.5)
Front Cover	
6M Bolt	2.9-5.8(.4-.8)
8M Bolt	7.2-11.6(1.0-1.6)
Rocker Pivot Lock Nuts	36-43(5-6)
Intake & Exhaust Manifolds	
8M Bolt	1-13(1.4-1.8)
10M Bolt	29-40(4.0-5.5)