

# Datsun Engines

## 610, 620, 710 4 CYLINDER

GENERAL SPECIFICATIONS										
Year	Displ.		Carburetor	HP at RPM	Torque (Ft. Lbs. at RPM)	Compr. Ratio	Bore		Stroke	
	cu. ins.	cc					in.	mm	in.	mm
1976 L20B	119.1	1952	1x2 Bbl.	.....	.....	8.5-1	3.35	85	3.39	86

### ENGINE IDENTIFICATION

Engine number is stamped on rear right side of cylinder block at cylinder head contact surface. The number is preceded by engine model L-20B.

### ENGINE REMOVAL

**NOTE** – It is recommended that engine and transmission be removed as a unit. Engine can then be separated from transmission.

**Model 620 (Pickup)** – 1) Mark alignment marks on hood and hood hinges, then remove hood. Disconnect battery ground cable. Remove the following before removing air cleaner: Blow-by hose, air pump-to-check valve hose, automatic temperature hot air duct, air cleaner duct, and idle compensator hose.

2) Remove canister hoses to intake manifold and vacuum gallery. Remove air pump-to-air pump air cleaner hose. Drain cooling system and crankcase. Remove radiator hoses and transmission oil cooler lines from radiator. Remove radiator and shroud. Disconnect heater hoses and engine ground cable.

3) Disconnect wires to following components: Accelerator wire at carburetor, coil lead, distributor, oil pressure switch, thermal transmitter, auto choke heater, vacuum control solenoid, anti-dieseling solenoid, alternator, starter, and back-up lamp switch.

4) Disconnect power brake unit vacuum hose at intake manifold. Disconnect speedometer cable from rear extension housing. On manual transmission models, remove floor cover, detach rubber boot, remove nut from shift lever, then remove shift lever. On automatic transmission models, remove screws to disconnect control knob from lever, then remove selector rod, range lever and control lever assembly with bracket.

5) Remove attaching screws, then disconnect clutch operating cylinder and flexible tube as an assembly on manual transmission models. Disconnect exhaust pipe from exhaust manifold. Disconnect center bearing bracket from crossmember and propeller shaft from flange at rear axle. Remove propeller shaft and plug rear end of transmission to prevent oil leakage.

6) Attach a lifting hoist to engine and remove front mount bolts at support. Support transmission with a floor jack and loosen two rear mounting bolts. Remove rear mount to side member bolts, and remove rear mount. Pull engine forward and carefully remove engine and transmission as an assembly.

**Model 610 & 710** – 1) Mark alignment marks on hood and hood hinges, then remove hood. Disconnect battery ground cable. Drain cooling system and crankcase. Disconnect transmission oil cooler lines and remove splash board on automatic transmission models.

2) Remove the following before removing air cleaner: Air ducts, air cleaner band bolt, air cleaner-to-air pump hose, air cleaner-to-rocker cover hose, air cleaner-to-air control valve hose, air cleaner-to-anti backfire valve hose, and all vacuum hoses to air cleaner.

3) Disconnect fuel pump hoses and carbon canister hose. Disconnect air pump-to-air pump air cleaner hose. Disconnect coil wire, ground cable from engine, distributor terminal wires at top of radiator, and starting motor "E" terminal wire. Disconnect mold type connectors found above front right engine mounting bracket and under ignition coil.

4) Disconnect power brake unit hose at intake manifold. Disconnect air conditioner vacuum hose from intake manifold. Remove fast idle control device (air conditioned models) from bracket. Disconnect flexible hoses at air conditioning compressor and plug hoses and openings to compressor.

5) Remove torsion shaft of accelerator linkage from carburetor. Disconnect heater hoses, then, remove radiator hoses, radiator shroud, radiator grille and radiator. On manual transmission models, detach rubber boot, remove nut from shift lever, and remove shift lever. On models with automatic transmission, disconnect joint between control lever and selector rod.

6) Disconnect speedometer cable from extension housing. Remove clutch operating cylinder from clutch housing. Remove heat shield insulators of front exhaust pipe and catalytic converter, then separate front exhaust pipe from converter on California models. On all models except California, disconnect front exhaust pipe from rear pipe.

7) Remove front exhaust pipe mounting and separate pipe from exhaust manifold. Disconnect center bearing bracket from crossmember and propeller shaft from flange at rear axle. Remove propeller shaft and plug rear end of transmission to prevent oil leakage. Support transmission with a floor jack.

8) Remove rear engine mounts and connect a lifting hoist to engine. Remove front engine mounts. Pull engine forward and carefully remove engine and transmission as an assembly.

### CYLINDER HEAD

**Removal** – 1) Drain cooling system. Remove air cleaner after disconnecting hoses and ducts. Disconnect spark plug wires from plugs and valve cover. Disconnect fuel hose from carburetor and remove fuel pump. Remove PCV hose and anti-backfire valve-to-EGR passage hose. Disconnect vacuum hoses and linkage to carburetor, then remove carburetor.

2) Disconnect all hoses and vacuum lines from intake manifold to cylinder head or block. Remove intake and exhaust manifold as an assembly. Remove rocker cover and fuel pump drive cam. Turn crankshaft so No. 1 piston is at TDC on its compression stroke. Paint alignment mark on timing chain and

## 610, 620, 710 4 CYLINDER (Cont.)

camshaft sprocket to aid in installation. Remove camshaft sprocket and use a special tool (ST17420001) to support timing chain as shown in illustration. Remove cylinder head attaching bolts and remove cylinder head.

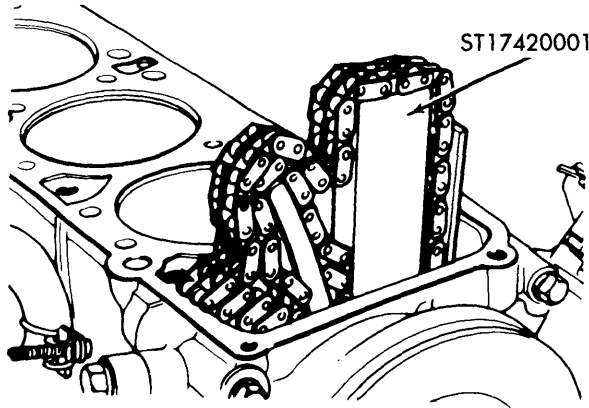

Fig. 1 Holding Timing Chain with Special Support Tool

**Installation** — To install, reverse removal procedure while noting the following: Do not use sealer on cylinder block or cylinder head. Install cylinder head and tighten attaching bolts, in three steps, in sequence shown in illustration. Make sure alignment marks on timing chain and camshaft sprockets are aligned.

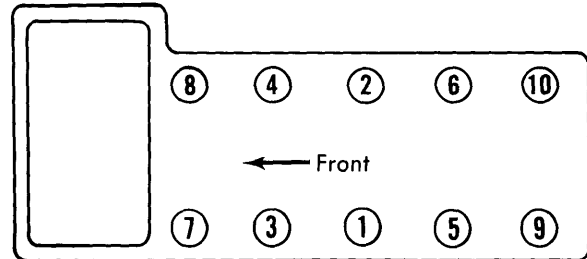

Fig. 2 Cylinder Head Tightening Sequence

VALVES							
Engine & Valve	Head Diam. In. (mm)	Face Angle	Seat Angle	Seat Width In. (mm)	Stem Diameter In. (mm)	Stem Clearance In. (mm)	Valve Lift In. (mm)
L20B Intake	1.654-1.661 (42.0-42.2)	45°	45°	.0551-.0630 (1.4-1.6)	.3136-.3142 (7.965-7.980)	.0008-.0021 (.020-.053)	.413 (10.5)
Exhaust	1.378-1.386 (.35.0-35.2)	45°	45°	.0709-.0866 (1.8-2.2)	.3128-.3134 (7.945-7.960)	.0016-.0029 (.040-.073)	.413 (10.5)

### VALVE ARRANGEMENT

E-I-I-E-E-I-I-E (front to rear).

### VALVE STEM CLEARANCE

1) Measure clearance between valve stem and valve guide with aid of micrometer and hole gauge. Check diameter of valve stem in three places: top, center and bottom.

2) Insert hole gauge in valve guide bore and measure at center. Subtract highest reading of valve stem diameter from valve guide bore to obtain clearance.

**NOTE** — As a quick check, a valve may be inserted into valve guide and moved either left or right (parallel with rocker arm). If tip moves about .0079" or more, clearance is beyond maximum limit of .0039".

### VALVE GUIDE REPLACEMENT

1) Remove old guide with press and drift pin. Although this procedure may be carried out at room temperature, higher temperatures will aid removal.

2) Ream cylinder head guide hole to provide an interference fit of .0011-.0019" (.027-.049 mm). Press new guide into cylinder head so that it will fit smoothly when cylinder head is heated to 302-392°

3) Ream bore of valve guides to .3150-.3157" (8.000-8.018 mm). Correct valve seat surface using new valve guide as axis.

### VALVE SEAT INSERTS

1) Check valve seats for pitting at valve contact surface. Valve seat inserts of .0197" oversize are available if necessary. To remove old inserts, bore out until old insert collapses. The depth stop on machine should be set so that boring cannot continue beyond bottom face of insert recess in cylinder head.

2) Machine cylinder head recess diameter to concentric circles to valve guide center so that insert will have correct fit. Heat cylinder head to 302-392°F and install insert making sure that it beds on bottom face of recess.

3) Valve seats should be cut or ground to correct face angle and seat width and to head diameter of valve to be installed.

# Datsun Engines

## 610, 620, 710 4 CYLINDER (Cont.)

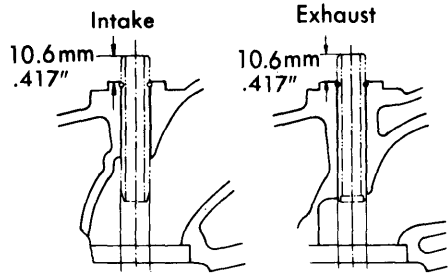

Fig. 3 Intake & Exhaust Valve Guides

VALVE SPRINGS			
Engine	Free Length In. (mm) ①	PRESSURE Lbs. @ In. (kg @ mm)	
		Valve Closed	Valve Open
L20B	Inner	27.1 @ 1.378 (12.3 @ 35.0)	56.2 @ .965 (25.5 @ 24.5)
	Outer	1.968 (49.98)	47 @ 1.575 (21.3 @ 40.0)

① - If valve spring is out-of-square more than .063" (1.6 mm), replace spring.

### VALVE ADJUSTMENT

Loosen pivot locking nut and turn pivot screw until specified clearance is obtained with engine cold. Tighten pivot locking nut after adjustment and recheck clearance. Warm up engine. With engine stopped, measure valve clearance and reset to hot clearances if necessary.

Valve	Hot	Cold
Intake	.010"(.25 mm)	.008"(.20 mm)
Exhaust	.012"(.30 mm)	.010"(.25 mm)

### VALVE SPRING INSTALLED HEIGHT

With valves closed, inner spring should have a height of 1.378" (35.0 mm) and outer spring should have a height of 1.575" (40.0 mm). See specifications for pressure with valves opened or closed.

PISTONS, PINS, RINGS						
Engine	PISTONS	PINS		RINGS		
	Clearance In. (mm)	Piston Fit In. (mm)	Rod Fit In. (mm)	Rings	End Gap In. (mm)	Side Clearance In. (mm)
L20B	.0010-.0018 (.025-.045)	.0001-.0006 (.003-.015)	① .0006-.0013 (.015-.033)	No. 1	.010-.016 (.25-.40)	.0016-.0029 (.040-.073)
				No. 2	.012-.020 (.30-.50)	.0012-.0028 (.030-.070)
				Oil	.012-.035 (.30-.90)	.....

① - Interference fit.

### PISTON & ROD ASSEMBLY

**Removal** - Remove connecting rod nuts and bearing caps. Push piston and rod assembly out top of cylinder, using care not to damage any bearing surface. Retain all components in proper order for reassembly in original location.

**Installation** - Reassemble piston and rod so that oil hole in connecting rod is facing right side of engine and notch on top of piston is facing forward. Install connecting rods on original journal with rod and cap marks on same side. Tighten connecting rod nuts and check rod side play.

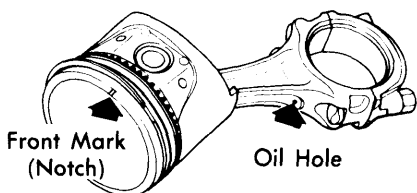

Fig. 4 Piston & Rod Assembly Installation Features

### FITTING PISTONS

1) Measure cylinder bores for wear or taper at top, bottom and middle on thrust face and at 90° to thrust face. If excessive wear is found, rebore cylinder and install oversize pistons. Oversize pistons are available as shown in table.

2) When boring cylinders, use cylinder order of 2-4-1-3 to prevent heat distortion. After honing cylinder to final fit, check piston fit using spring tension pull scale. A force of .44-3.31 lbs. (.2-1.5 kg) should be obtained extracting a .0016" (.04 mm) feeler gauge.

3) Measure piston ring end gap and side clearance and replace as necessary. Install rings on piston with end gaps 180° apart and so no end gap is inline with thrust face. Install rings with top mark facing upward.

**NOTE** - If only piston ring is to be replaced, measure gap at bottom of bore. Oversize rings are available in .020" (.50 mm) and .040" (1.00 mm).

## 610, 620, 710 4 CYLINDER (Cont.)

### Piston Specifications

Application In.(mm)	Piston Size In.(mm)
Standard .....	3.3451-3.3470(84.965-85.015)
.020(.50) OS .....	3.3648-3.3667(85.465-85.515)
.040(1.00) OS .....	3.3844-3.3864(85.965-86.015)

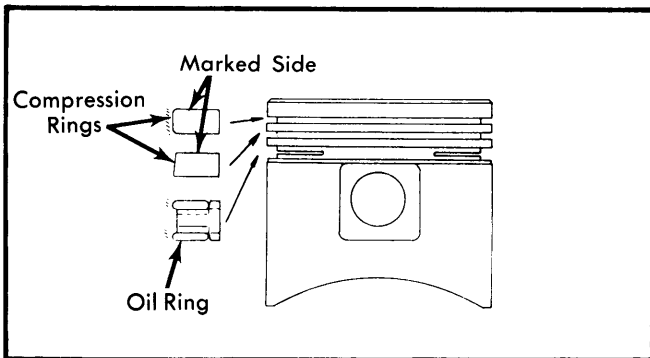

Fig. 5 Installation Order of Piston Rings

### PISTON PINS

Pin must be a tight press fit in connecting rod, pressing force is from one to one and a half tons. When pressing pin into connecting rod, oil pin and press pin so that oil jet of connecting rod large end is directed toward right side of cylinder block.

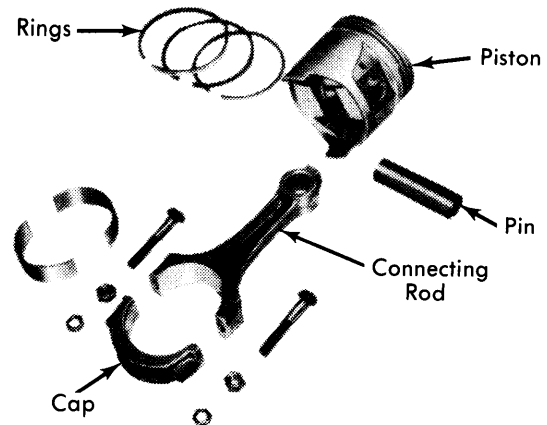

Fig. 6 Exploded View of Piston & Rod Assembly

### CRANKSHAFT MAIN & CONNECTING ROD BEARINGS

Engine	MAIN BEARINGS				CONNECTING ROD BEARINGS		
	Journal Diam. In. (mm)	Clearance In. (mm)	Thrust Bearing	Crankshaft End Play In. (mm)	Journal Diam. In. (mm)	Clearance In. (mm)	Side Play In. (mm)
L20B	2.3599-2.3604 (59.942-59.955)	.0008-.0024 (.020-.062)	No. 3	.002-.007 (.05-.18)	1.9670-1.9675 (49.961-49.974)	.001-.002 (.025-.055)	.0079-.0118 (.20-.30)

### CRANKSHAFT

**Removal** - With engine removed from vehicle, remove cylinder head and oil pan. Remove flywheel and rear plate. Remove oil strainer, oil pump and drive spindle. Remove front cover, chain tensioner, chain slack side guide, and timing chain. Remove oil thrower, crankshaft worm gear, and chain drive sprocket. Remove piston and rod assemblies. Remove main bearing caps using a special puller (ST1651S000) to remove center and rear main bearing caps. **NOTE** - Keep all main bearing caps in order to aid in reassembly. Remove rear oil seal, then remove crankshaft.

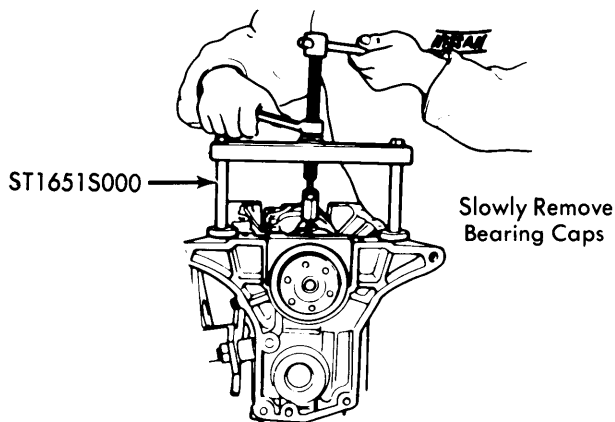

Fig. 7 Rear Main Bearing Cap Removal

**Inspection** - Check all shaft journals for scoring, wear, or cracks. Taper and out-of-round of all journals must not exceed .001" (.025 mm). Check crankshaft for bend using a dial indicator at center journal of crankshaft. If bend exceeds .004" (.10 mm), which is one-half of indicator reading, replace crankshaft. Check main driveshaft pilot bearing at rear of crankshaft for wear or damage and replace if necessary.

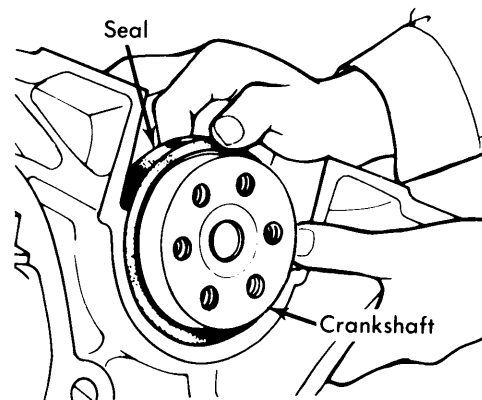

Fig. 8 Rear Oil Seal Removal

**Installation** - 1) Install main bearing halves to engine block ensuring that all bearings are on correct journal. Journal No. 3 requires a thrust bearing. Bearing for journal No. 1 is the

## 610, 620, 710 4 CYLINDER (Cont.)

same as for journal No. 7 except that an oil hole is provided in No. 1. Upper and lower bearings are interchangeable.

2) Apply oil to main bearing surface and install crankshaft. Install main bearing caps with arrow pointing toward front of engine. **NOTE** — Apply sealer to rear main bearing cap at point where cap contacts cylinder block. Shift crankshaft toward front of engine, then tighten main bearing caps, in two or three steps, starting at center bearing and working outwards. Ensure crankshaft rotates smoothly.

3) Check crankshaft end play, and if not within specifications, replace center thrust bearing. Install side seals in rear main bearing cap after applying sealer to seals. Install rear oil seal. Install rear end plate and flywheel. Install piston and rod assemblies. Install remaining components in reverse of removal procedure.

## MAIN BEARING CLEARANCE

1) Check all bearings for scoring or wear and replace if damage is found. Clean oil from crankshaft and place a strip of Plastigage on crankshaft journal. **NOTE** — Plastigage should run parallel with crankshaft journal and should not block oil hole. Install main bearing cap, with bearing installed, and tighten to 33-40 ft. lbs. (4.5-5.5 mkg). **NOTE** — Do not turn crankshaft while Plastigage is inserted.

2) Remove cap and measure width of Plastigage at widest point using gauge provided with Plastigage. If clearance is not to specifications, replace bearings. Bearings are available in undersizes of .01" (.25 mm), .02" (.50 mm), .03" (.75 mm), and .04" (1.0 mm).

3) Bearings are manufactured with crush to cause bearing to snug down into bore. To measure, set bearing in cap or cylinder block and lock one side end of bearing. Press other side of bearing until back surface touches bore. Measure bearing crush, as shown in illustration, using a feeler gauge. Measurement must be 0-.0012" (0-.03 mm).

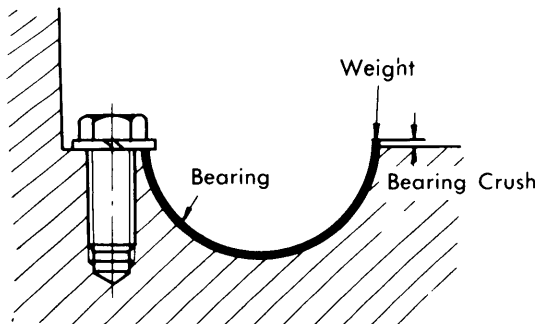

Fig. 9 Measuring Bearing Crush in Cylinder Block

## CONNECTING ROD BEARING CLEARANCE

Check connecting rod bearing clearance in same manner as main bearing clearance using Plastigage. Tighten connecting rod caps to 33-40 ft. lbs. (4.5-5.5 mkg). Bearings are

available in undersizes of .0024" (.06 mm), .005" (.12 mm), .01" (.25 mm), .02" (.50 mm), .03" (.75 mm), and .04" (1.0 mm). Check bearing crush of connecting rod bearings in same manner as for main bearings. Clearance must be .0006-.0018" (.015-.045 mm).

## ENGINE FRONT COVER

**Removal** — Drain cooling system, disconnect hoses and remove radiator. Remove all drive belts, fan blade and pulley. Disconnect all wiring and connections to thermostat housing and remove housing. Remove crankshaft pulley and water pump. Remove spark plug wires from plugs, mark position of distributor base to engine and position of rotor to distributor. Disconnect distributor wires from coil and remove distributor. Remove oil pump with its drive spindle. Remove front cover attaching bolts and front cover.

CAMSHAFT			
Engine	Journal Diam. In. (mm)	Clearance In. (mm)⓪	Lobe Lift In. (mm)
L20B	1.8877-1.8883 (47.948-47.963)	.0015-.0026 (.038-.067)	.276 (7.0)

⓪ — End play is .003-.015" (.08-.38 mm).

## CAMSHAFT

**Removal** — Remove cylinder head. Remove valve rocker spring. Loosen valve rocker pivot lock nuts and remove rocker arms by pressing down on spring. Use care not to lose valve rocker guide. Carefully remove camshaft from front of cylinder head.

**Installation** — Carefully install camshaft into cylinder head taking care not to damage bearings. Install camshaft locating plate with oblong groove of plate facing front of cylinder head. Install camshaft sprocket and tighten attaching bolt. Install remaining components in reverse of removal procedure, and tighten all nuts and bolts.

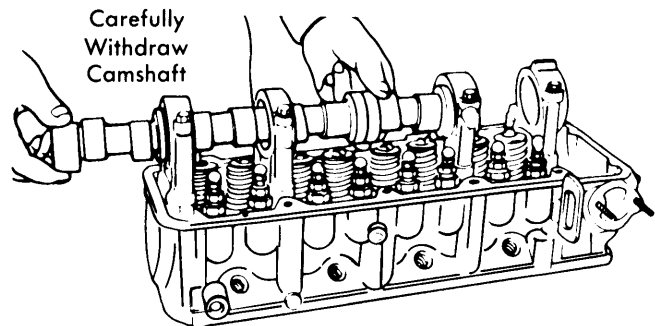

Fig. 10 Withdrawing Camshaft from Cylinder Head

## 610, 620, 710 4 CYLINDER (Cont.)

### CAMSHAFT BEARINGS

**NOTE** — Do not remove camshaft bearings. If bearings are removed, bearing centers will be out of alignment and proper reassembly will be difficult without center boring.

Measure inner diameter of camshaft bearing and outer diameter of camshaft journal. If wear or damage is excessive, replace cylinder head assembly.

### TIMING CHAIN & GEARS

Remove engine front cover and camshaft drive sprocket and fuel pump cam. Remove timing chain, tensioner and chain guide. Remove oil thrower, crankshaft worm gear and crankshaft chain drive gear. To install, reverse removal procedure.

**NOTE** — When installing timing chain, camshaft gear or crankshaft gear, make sure camshaft and crankshaft keys point upward. Set timing chain so that mating marks align with crankshaft and camshaft sprockets. There are 44 chain links between the two timing chain marks.

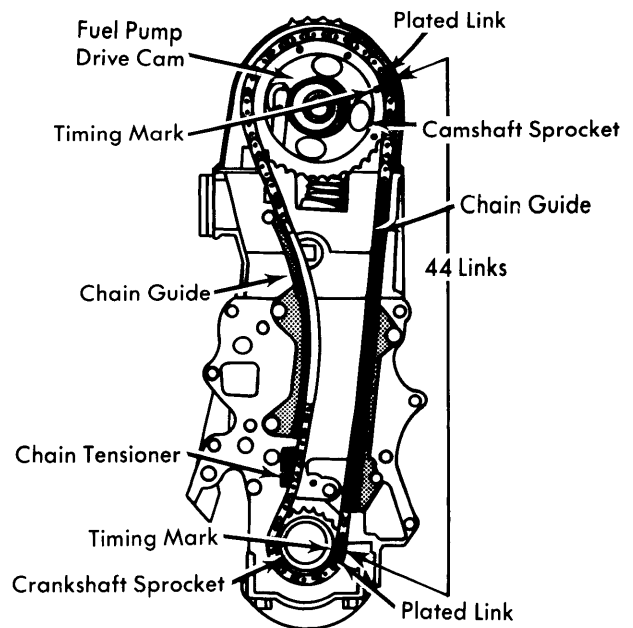

Fig. 11 Timing Chain & Sprocket Alignment

### ENGINE OILING

**Crankcase Capacity** — 4.5 quarts with filter change.

**Oil Filter** — Full-flow, disposable cartridge.

**Oil Pressure** — 11-40 psi (.8-2.8 kg/cm<sup>2</sup>) @ idle, 50-70 psi (3.5-5.0 kg/cm<sup>2</sup>) @ maximum.

**Pressure Relief Valve** — Non-adjustable.

passages in crankshaft. Oil sprayed from jet holes on connecting rods lubricates cylinders and piston pins. Oil from main gallery lubricates chain tensioner and timing chain. A center oil hole in crankshaft center bearing feeds camshaft bearings on cylinder head. Valve rocker mechanism is lubricated through oil gallery in camshaft and through a small channel at base circle portion of each cam. Rocker arms and valves are lubricated intermittently through small holes or oil pipe.

### OIL PUMP

Pump assembly is installed to bottom of front cover by four bolts. Pump driven by distributor drive shaft is rotor type. To remove, first remove distributor. Drain engine oil, remove splash shield and stabilizer. Remove oil pump body together with drive shaft. To disassemble proceed as follows:

- 1) Separate body cover from oil pump body by unscrewing attaching screws. Take out pump drive and driven gears from pump body.

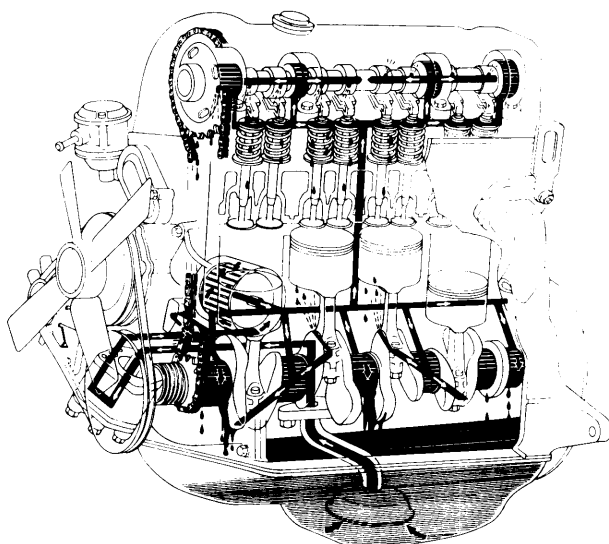

Fig. 12 Cutaway View of Engine Oiling System

### ENGINE OILING SYSTEM

Oil drawn from oil pan passes through screen to oil pump and is delivered to full flow oil filter and to main oil gallery. Main oil gallery supplies oil to crankshaft main bearings and drilled

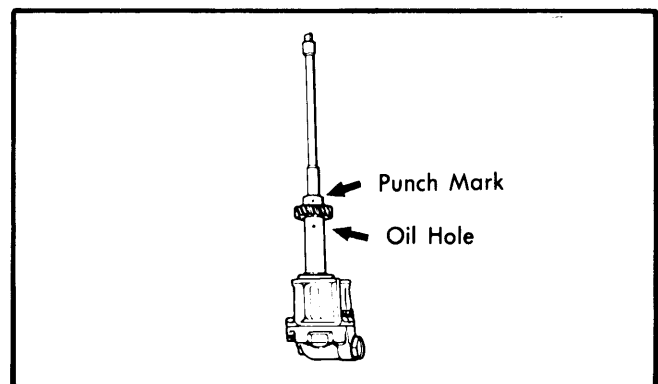

Fig. 13 Aligning Oil Pump Timing Mark

# Datsun Engines

## 610, 620, 710 4 CYLINDER (Cont.)

### ENGINE OILING (Cont.)

2) Clean parts with cleaning solvent, and inspect for wear or damage. Make sure clearances are to specifications. Pump is serviced as an assembly only. Replace pump if any part is worn or damaged.

3) Rotate engine until number one piston is at TDC. Fill pump housing with oil and align punch mark on shaft with hole in pump (see illustration). Using a new gasket, install oil pump and drive shaft assembly so that tongue is positioned at 11:25 o'clock. Small crescent will be facing forward (see illustration). Check drive gear engagement through distributor mounting hole.

Oil Pump Specifications	
Application	Clearance In. (mm)
Inner-to-Outer Rotor .....	.0016-.0031 (.04-.08)
Tip Clearance .....	Less Than .005 (.12)
Outer Rotor-to-Body .....	.006-.008 (.15-.21)
Rotor-to-Bottom Cover.....	.001-.005 (.03-.12)

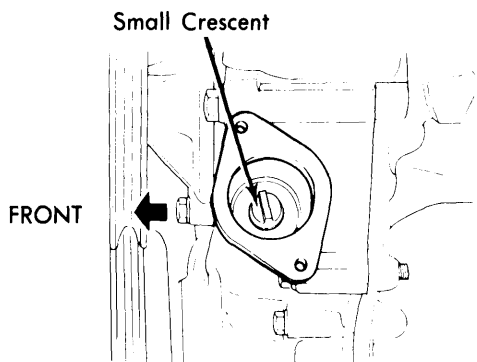

Fig. 14 Positioning Oil Pump Drive in Engine

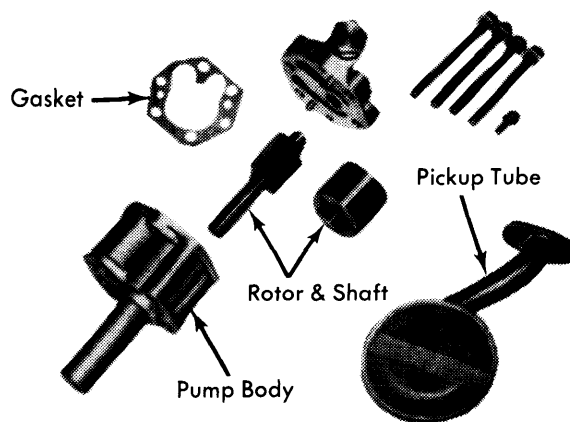

Fig. 15 Exploded View of Oil Pump & Pickup Tube

### ENGINE COOLING

**Thermostat** – Opens at 180°F (82°C). Full open at 203°F (95°C).

**Radiator Cap** – 13 psi.

**Cooling System Capacity** – 7.25 quarts all models.

#### WATER PUMP

Centrifugal type pump with aluminum body. To remove, drain cooling system and remove upper and lower radiator shrouds. Remove fan belt, fan, and pulley. Remove pump attaching bolts and remove water pump.

TIGHTENING SPECIFICATIONS	
Application	Ft. Lbs.(mkg)
Cylinder Head	
Step One .....	29(4.0)
Step Two .....	43(6.0)
Step Three .....	47-61(6.5-8.4)
Connecting Rods .....	33-40(4.6-5.5)
Flywheel .....	101-116(14-16)
Main Bearings .....	33-40(4.6-5.5)
Camshaft Sprocket .....	86-116(12-16)
Oil Pan .....	4.3-6.5(.6-.9)
Crankshaft Pulley .....	87-116(12-16)
Manifolds .....	9-12(1.2-1.7)
Rocker Pivot Lock Nuts .....	36-43(5-6)