

## B210 & F10 4 CYLINDER

GENERAL SPECIFICATIONS										
Year	Displ.		Carburetor	HP at RPM	Torque (Ft. Lbs. at RPM)	Compr. Ratio	Bore		Stroke	
	cu. ins.	cc					in.	mm	in.	mm
1976	85.24	1397	1 x 2-Bbl.	.....	.....	8.5-1	2.99	76	3.03	77

### ENGINE IDENTIFICATION

Engine serial and code number is stamped on right rear side of cylinder block, below mating surface of cylinder head and cylinder block. First three digits are engine code.

Application	Code
1397 cc .....	A14

### ENGINE REMOVAL

**NOTE** — Manufacturer recommends that engine and transmission be removed as an assembly.

- 1) Disconnect battery ground and fusible link. Mark hood hinge location and remove hood. Drain coolant from radiator and engine. Remove radiator shroud, disconnect upper and lower hoses and remove radiator.
- 2) Drain engine oil, then disconnect all electrical wiring and vacuum hoses from engine and transmission. Disconnect fuel line at fuel pump.
- 3) Remove air cleaner and disconnect accelerator control wire. Disconnect hoses from air conditioning compressor, air pump hoses, carbon canister hoses, altitude compensator hoses (Calif. models), emergency air relief valve hoses (Calif. only), vacuum hoses, and heater hoses.
- 4) Disconnect hydraulic lines and remove clutch slave cylinder on vehicles with manual transmission. Disconnect speedometer cable at transmission. Disconnect selector range lever (automatic transmissions) or gear shift control lever (manual transmissions).
- 5) Disconnect exhaust pipe from exhaust manifold. On models with catalytic converter, remove sensor harness protector and two front pipe clamps. Secure exhaust pipe to body frame to prevent from falling. Remove propeller shaft and plug extension housing to prevent oil leakage. **NOTE** — Mark propeller shaft and flange so installation will be in the original position.
- 6) Support transmission using a floor jack. Remove rear engine mount-to-body bolts. Support engine using suitable hoist and sling assembly, then remove engine front mounting

brackets-to-engine mount attaching bolts. Remove engine and transmission as an assembly

### INTAKE & EXHAUST MANIFOLDS

**Removal & Installation** — 1) Remove air cleaner and disconnect accelerator cable and choke cable. Disconnect and plug fuel line at carburetor. Disconnect exhaust pipe at exhaust manifold.

2) Remove nuts retaining intake and exhaust manifold to cylinder head and remove intake and exhaust manifold as an assembly. Remove gasket and thoroughly clean mating surfaces. Remove bolts and separate intake and exhaust manifold. To install, reverse removal procedure and use new gasket. Tighten nuts and bolts to specifications.

### CYLINDER HEAD

**Removal** — Remove manifold assembly as previously outlined. Remove rocker arm cover, rocker arm assembly, and push rods. Remove cylinder head retaining bolts and remove cylinder head.

**Installation** — Thoroughly clean mating surfaces. Use new gasket with no sealer and install cylinder head. Install cylinder head retaining bolts. **NOTE** — One cylinder head bolt is smaller diameter and has a hollow head. Install this bolt on right side center of cylinder head. Tighten cylinder head bolts in two or three steps to specifications in sequence as shown in illustration. Reverse removal procedure to install remaining components. Adjust valve clearance.

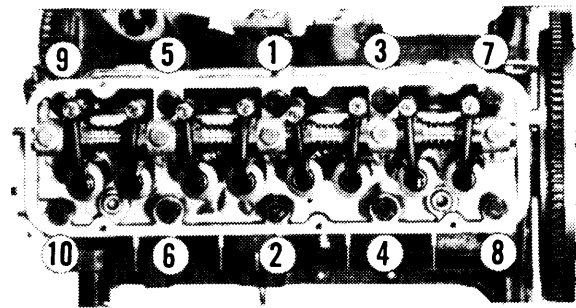

Fig. 1 Tightening Sequence for Cylinder Head

VALVES							
Engine & Valve	Head Diam. In. (mm)	Face Angle	Seat Angle	Seat Width In. (mm)	Stem Diameter In. (mm)	Stem Clearance In. (mm)	Valve Lift In. (mm)
1397cc Int.	1.46 (37)	45.5°	45°	.0512 (1.3)	.3138-.3144 (7.970-7.985)	.0006-.0018 (.015-.045)	.3114 (7.91)
Exh.	1.18 (30)	45.5°	45°	.0709 (1.8)	.3128-.3134 (7.945-7.960)	.0016-.0028 (.040-.070)	.3236 (8.22)

## B210 & F10 4 CYLINDER (Cont.)

### VALVE ARRANGEMENT

E-I-I-E-E-I-I-E (front to rear).

### VALVE GUIDE SERVICING

Check valve stem-to-guide clearance. If clearance is more than .0039" (.1 mm) and valve stem is not worn, valve guide must be replaced. Replace valve guide using the following procedure.

1) Using suitable tool (ST11320000), remove guide from cylinder head. Ream guide hole in cylinder head to .4803-.4807" (12.19-12.21 mm) to install replacement guide.

2) Heat cylinder head to approximately 302-392°F (150-200°C). Install guide using same driver as used for removal. Ream valve stem bore in guide to .3150-.3156" (8.00-8.015 mm) using a suitable reamer (ST110320000). Reface valve seat surface.

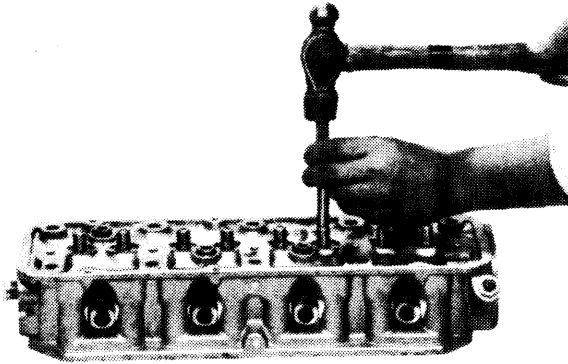

Fig. 2 Installation of Valve Guides

### VALVE STEM OIL SEALS

An oil seal is installed on all valve stems inside valve spring. Install seal with large end over valve guide.

### VALVE SPRINGS

**Removal** — With cylinder head removed, compress valve spring using a suitable valve spring compressor (ST12070000) and remove valve keepers. Release spring compressor and remove spring retainer and spring.

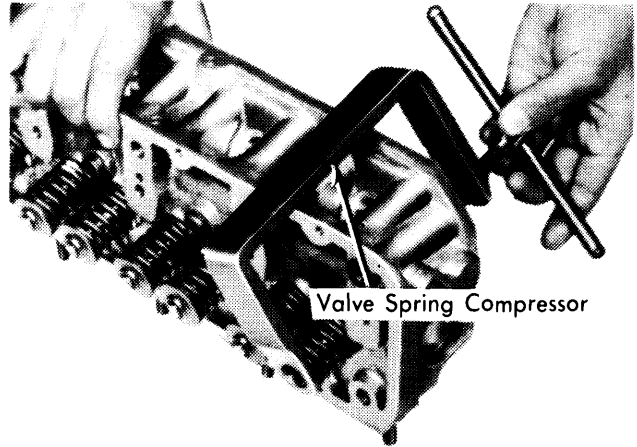

Fig. 4 Removing the Valve Spring

**Installation** — Install valve spring with white painted end toward cylinder head. Install valve spring retainer. Compress valve spring using removal tool and install valve keepers.  
**NOTE** — Make sure valve is properly seated on spring seat.

### VALVE SPRING INSTALLED HEIGHT

Valve spring must be square within  $\frac{1}{16}$ ". Valve spring installed height is 1.52" (38.7 mm). Check valve spring by applying specified load and measuring spring height. If spring height and pressure, or squareness does not meet specifications, replace spring.

### ROCKER ARM ASSEMBLY

1) Remove valve cover and remove bolts securing rocker arm assembly to cylinder head. Remove rocker arm assembly.

2) Slide off support stands, rocker arms and springs. Thoroughly clean and inspect all components for signs of wear or seizure. Measure rocker arm-to-shaft clearance. Standard clearance is .0008-.0021" (.020-.054 mm). Replace as necessary.

VALVE SPRINGS			
Engine	Free Length In. (mm)	PRESSURE Lbs. @ In. (kg @ mm)	
		Valve Closed	Valve Open
All	1.831 (46.5)	52.7 @ 1.52 (23.9 @ 38.7)	129 @ 1.189 (58.5 @ 30.2)

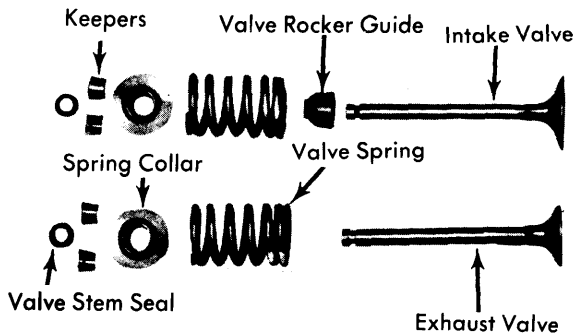

Fig. 3 Disassembled View of Valve Assemblies

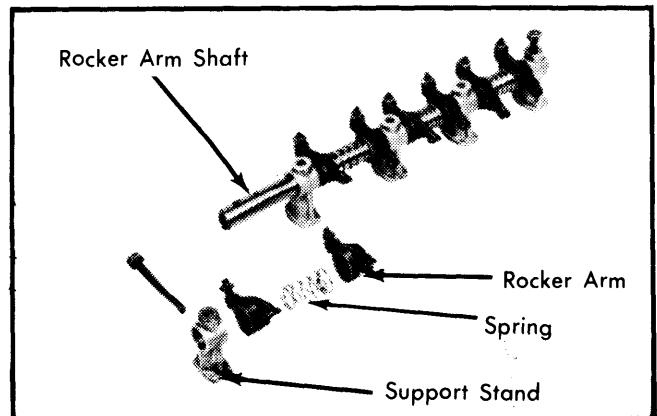

Fig. 5 Rocker Arm Assembly Components

## B210 & F10 4 CYLINDER (Cont.)

3) If valve contact surface of rocker arm is worn, resurface using a suitable grinder.

4) Reverse disassembly and removal procedures to assemble and install rocker arm assembly. Tighten bolts to specifications and adjust valve clearance.

### VALVE TAPPET SERVICE

Check valve tappet for signs of wear or seizure. Check clearance between valve tappet and tappet bore in

crankcase. If clearance is more than .0059" (.15 mm), replace valve tappet. Standard clearance is .0008-.0020" (.02-.05 mm).

### VALVE CLEARANCE ADJUSTMENT

Rotate engine until piston of valves being adjusted is at TDC of compression stroke. Adjust both intake and exhaust valves to .010" (.25 mm) with engine cold. With engine hot, readjust valve clearance on both intake and exhaust valves to .014" (.35 mm).

PISTONS, PINS, RINGS						
Engine	PISTONS		PINS		RINGS	
	Clearance In. (mm)	Piston Fit In. (mm)	Rod Fit In. (mm)	Rings	End Gap In. (mm)	Side Clearance In. (mm)
All	.0009-.0017 (.023-.043)	.0003-.0005 (.008-.012)	.0007-.0014 <sup>Ⓞ</sup> (.017-.035)	1	.0079-.0138 (.20-.35)	.0016-.0028 (.04-.07)
				2	.0059-.0118 (.15-.30)	.0011-.0024 (.03-.06)
				Oil	.0118-.0354 (.30-.90)	snug snug

Ⓞ — Interference fit.

### PISTON & ROD ASSEMBLY

1) Remove cylinder head and oil pan. Remove nuts from connecting rod and remove connecting rod cap with bearing half. Push piston and connecting rod assembly with bearing half up and out through top of crankcase.

2) To install piston and connecting rod assembly, thoroughly oil rings, piston and cylinder wall. Make sure ring gaps are situated approximately 180° apart and not on thrust side of piston. Make sure bearing halves are properly seated in connecting rod and cap.

3) Install a ring compressor and compress rings. Install piston in cylinder with number on top of piston toward front of engine. With piston installed in cylinder, and connecting rod and bearings seated against crankshaft journal, install rod cap with numbers on the same side as connecting rod. Tighten nuts to specification.

4) Install cylinder head and oil pan as previously outlined.

### FITTING PISTONS

1) Check piston-to-cylinder clearance with a feeler gauge and spring tension gauge. With a .0016" (.04 mm) feeler gauge installed between piston and cylinder wall, a force of 1.1-3.3 lbs. (.5-1.5 kg) measured on spring tension gauge, should be needed to extract feeler gauge.

2) Measure piston diameter at top of skirt 90° to piston pin axis. Measure cylinder bore halfway down cylinder and 90° to crankshaft center line. Pistons and rings are available in standard and two oversizes.

### Piston Specifications

Application In.(mm)	Piston Size In.(mm)
Std. ....	2.9908-2.9927(75.967-75.6.017)
.020(.50) O/S .....	3.0105-3.0124(76.467-76.517)
.040(1.0) O/S .....	3.0301-3.0321(76.967-77.017)

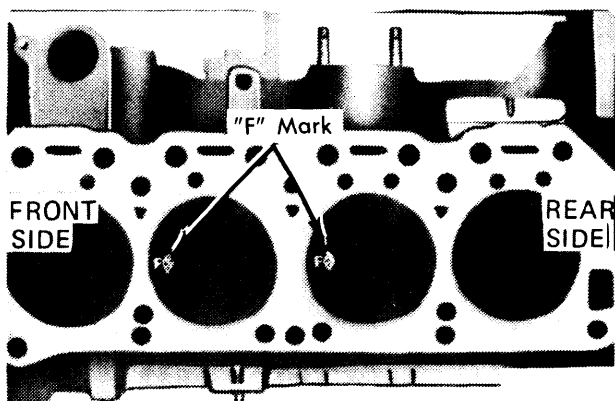

Fig. 6 Correct Installed Piston Position

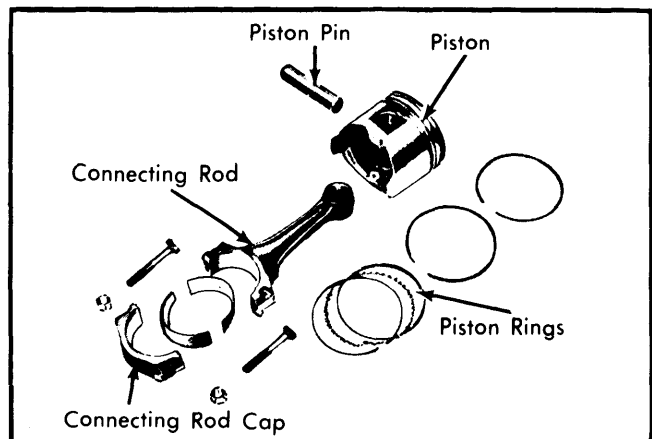

Fig. 7 Disassembled View of Piston and Connecting Rod Assembly

# Datsun Engines

## B210 & F10 4 CYLINDER (Cont.)

### PISTON PIN REPLACEMENT

- 1) Remove piston and connecting rod assembly as previously outlined. Piston pin is press fit in connecting rod and is removed using a press and suitable pin press stand (ST13040000).
- 2) Check piston-to-pin clearance. If clearance is not within specifications, replace both piston and piston pin. Piston pin should push fit through piston by hand with both piston and pin at room temperature.
- 3) Piston pin should be press fit into connecting rod. If interference fit is not within specifications, replace connecting rod or piston pin as necessary. If connecting rod is replaced, insure that new rod is within .176 ounces (5 grams) of defective connecting rod.
- 4) To assemble piston and connecting rod assembly, use same mandral and driver used for disassembly. Thoroughly oil pin, piston and connecting rod. Install piston on connecting rod so

that number on top of piston is pointing toward front of engine and oil squirt hole on connecting rod is toward right side of crankcase.

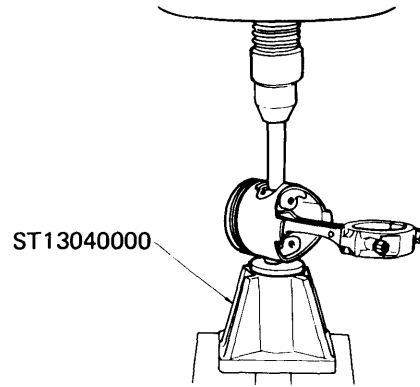

Fig. 8 Removing and Installing Piston Pin

CRANKSHAFT MAIN & CONNECTING ROD BEARINGS							
Engine	MAIN BEARINGS				CONNECTING ROD BEARINGS		
	Journal Diam. In. (mm)	Clearance In. (mm)	Thrust Bearing	Crankshaft End Play In. (mm)	Journal Diam. In. (mm)	Clearance In. (mm)	Side Play In. (mm)
All	1.9666-1.9671 (49.95-49.96)	.0008-.0024 (.020-.062)	No. 3	.0020-.0059 (.050-.150)	1.7701-1.7706 (44.96-44.97)	.0008-.0020 (.020-.050)	.008-.012 (.20-.30)

### MAIN & CONNECTING ROD BEARINGS

**Removal** — With engine removed from vehicle, remove cylinder head, oil pan, and piston and connecting rod assemblies. Remove alternator and engine mounting bracket from left side. Remove water pump, crankshaft pulley, and timing chain cover. Remove oil thrower and chain tensioner. Remove camshaft sprocket bolt, and remove both sprockets and timing chain as an assembly. Remove clutch and flywheel. Loosen main bearing cap bolts in two or three steps, then remove caps. Remove rear oil seal and carefully lift out crankshaft.

**Inspection** — 1) Thoroughly clean and inspect crankshaft. Blow out oil passages with compressed air. Check crankshaft for runout on center main bearing journal. If runout is more than .002" (.05 mm), crankshaft is bent and must be replaced.

2) Check all main and connecting rod bearings using Plastigage method. Check main and connecting rod journals for out-of-round or taper. If more than .0012" (.03 mm), crankshaft must be ground to next undersize. Main and connecting rod journals may be ground to the undersizes indicated in tables.

#### Main Bearing Journals

Application In. (mm)	Diameter In. (mm)
Std. ....	1.9666-1.9671 (49.951-49.964)
.001 (.02) .....	1.9665-1.9670 (49.949-49.962)
.01 (.25) .....	1.9567-1.9572 (49.701-49.714)
.02 (.50) .....	1.9469-1.9474 (49.451-49.464)
.03 (.75) .....	1.9370-1.9376 (49.201-49.214)
.04 (1.0) .....	1.9272-1.9277 (48.951-48.964)

### Connecting Rod Journals

Application In. (mm)	Diameter In. (mm)
Std. ....	1.7701-1.7706 (44.961-44.974)
.003 (.08) .....	1.7670-1.7675 (44.881-44.894)
.005 (.12) .....	1.7654-1.7659 (44.841-44.854)
.01 (.25) .....	1.7603-1.7608 (44.711-44.724)
.02 (.50) .....	1.7504-1.7509 (44.461-44.474)
.03 (.75) .....	1.7406-1.7411 (44.211-44.224)
.04 (1.0) .....	1.7307-1.7313 (43.961-43.974)

**Installation** — 1) Install main bearing halves to engine block ensuring that all bearings are on correct journal. Bearings for journal No. 1 and No. 5 are the same. Bearings for journals No. 2 and No. 4 are the same. Journal No. 3 requires the thrust bearing. Upper and lower bearings are not interchangeable except for journals No. 2 and No. 4.

2) Apply oil to main bearing surface and install crankshaft. Install main bearing caps with arrow pointing toward front of engine. **NOTE** — Apply sealer to main bearing caps at point where cap contacts cylinder block. Tighten main bearing caps, in two or three steps, starting at center bearing and working outwards. Ensure crankshaft rotates smoothly.

3) Check crankshaft end play. See *Thrust Bearing Alignment*. Install timing chain in correct position with crankshaft and camshaft sprockets. Install rear oil seal. Install clutch and flywheel. Install oil thrower and chain tensioner. Install timing chain cover, crankshaft pulley, and water pump. Install alternator and engine mounting bracket. Install piston and connecting rod assemblies, oil pan, and cylinder head.

## B210 & F10 4 CYLINDER (Cont.)

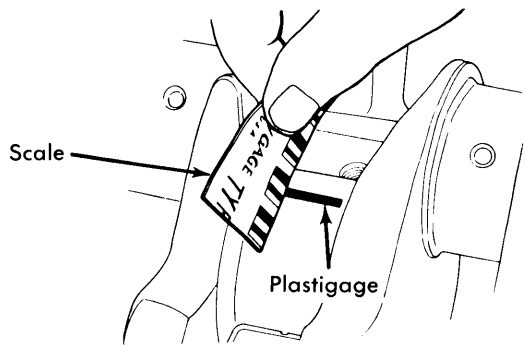

Fig. 9 Checking Bearings with Plastigage Method

### THRUST BEARING ALIGNMENT

Thrust bearing is installed on No. 3 main bearing journal. Check crankshaft end play by inserting a feeler gauge between flange of thrust bearing and crankshaft. End play should be  $.002-.006$ " ( $.05-.15$  mm).

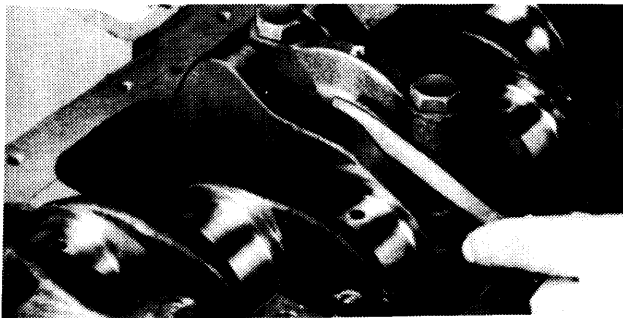

Fig. 10 Checking Crankshaft End Play

### REAR MAIN BEARING OIL SEAL SERVICE

Apply sealer to corners of crankcase that holds rear main bearing cap. Apply light grease to sealing edge on seal and install seal. Install rear main bearing cap and tighten bolts to specifications.

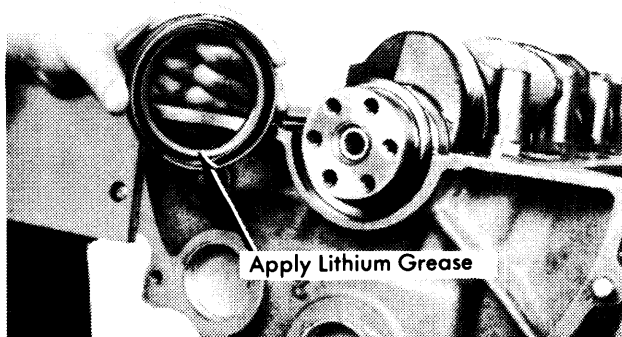

Fig. 11 Installing Rear Main Bearing Oil Seal

### ENGINE FRONT COVER & OIL SEAL

**Removal & Installation** — Remove drive belt, fan, and water pump pulley. Remove water pump and crankshaft pulley. Remove oil pan and front cover. Replace seal in front cover whenever cover is removed. Thoroughly clean mating surfaces and apply sealer to both sides of gasket. Install gasket and cover. Tighten bolts and nuts to specifications. Reverse removal procedure to install remaining components.

CAMSHAFT			
Engine	Journal Diam. In. (mm)	Clearance In. (mm)	Lobe Lift In. (mm)
All No. 1	1.7237-1.7242 (43.78-43.80)	.0015-.0024 (.037-.060)	Int. .222 (5.65)
2	1.7041-1.7046 (43.28-43.30)	.0011-.0020 (.027-.050)	Exh. .233 (5.92)
3	1.6844-1.6849 (42.78-42.80)	.0016-.0025 (.040-.063)	
4	1.6647-1.6652 (42.28-42.30)	.0011-.0020 (.029-.050)	
5	1.6224-1.6229 (41.21-41.22)	.0015-.0024 (.037-.060)	

### TIMING CHAIN

**Removal** — Remove engine front cover as previously outlined. Remove timing chain tensioner and bolt securing camshaft sprocket to camshaft. Pull off sprocket with timing chain.

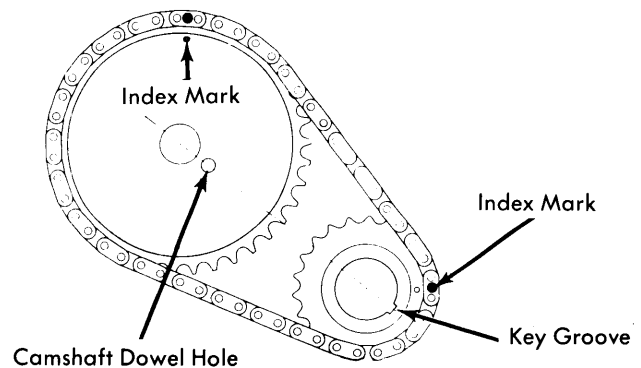

Fig. 12 Correct Alignment for Timing Chain Installation

**Installation** — Install timing chain and camshaft sprocket with markings correctly aligned as shown in illustration. Oil sprocket teeth and chain with engine oil. Install and tighten camshaft sprocket bolt. Install chain tensioner and tighten attaching bolts. Check dimension "L" of tensioner, and if over  $.591$ " (15 mm), replace chain tensioner. Install oil thrower in front of camshaft sprocket. Install timing chain cover.

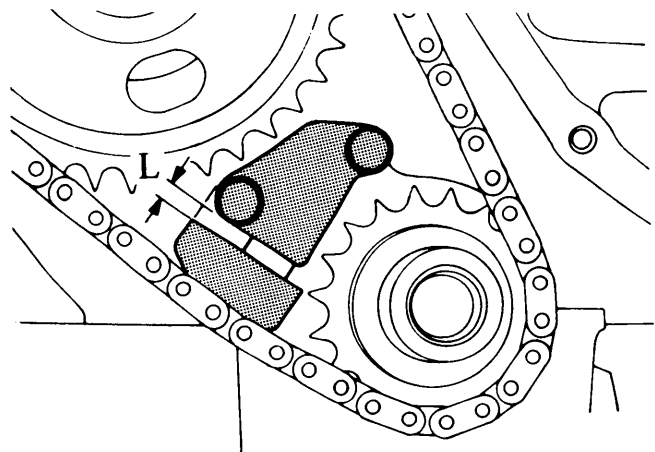

Fig. 13 Checking the Timing Chain Tensioner

# Datsun Engines

## B210 & F10 4 CYLINDER (Cont.)

### CAMSHAFT

**Removal** — Remove engine front cover, and valve train components as previously outlined. Remove fuel pump and oil pump with filter. Remove timing chain tensioner and remove timing chain with sprockets. Remove two bolts from camshaft lock plate and carefully pull camshaft from engine block.

**Inspection** — Thoroughly clean and inspect camshaft for wear or scoring. Check runout of camshaft using a dial indicator on center bearing journal. If runout exceeds .002" (.05 mm), replace camshaft. Check journal diameter, and if diameter is more than .0039" (.10 mm) from standard, camshaft journals must be ground to next undersize. Bearings are available in standard and three undersizes.

**Installation** — Coat camshaft with light coat of engine oil and carefully install camshaft into engine. Install camshaft lock plate with word "LOWER" at bottom. Install valve train components. Install timing chain with sprockets and timing chain tensioner. Install engine front cover. Install fuel pump and oil pump.

### CAMSHAFT BEARING REPLACEMENT

1) With camshaft removed, check journal diameter and bearing inside diameter. If journal measurement is within tolerance and clearance between camshaft journals and bearings exceeds .0059" (.15 mm), bearings must be replaced.

2) Remove and install appropriate bearings in crankcase using a suitable driver (ST16110000). Make sure oil holes in bearings align with oil holes in crankcase. Bearings must be line bored after installation. Install taper plug in crankcase using sealer. Install camshaft as previously outlined.

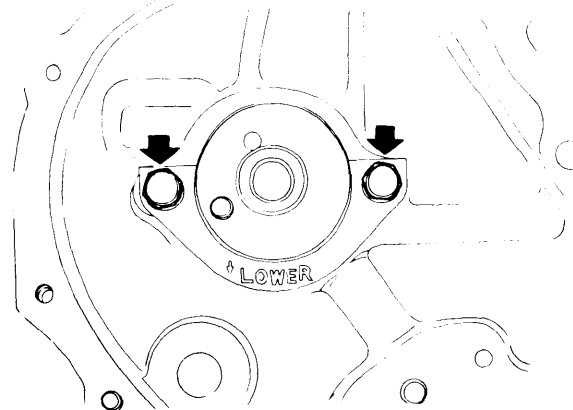

Fig. 14 Correct Camshaft Lock Plate Installation

### CAMSHAFT END THRUST

Check camshaft end thrust with camshaft, lock plate, and camshaft sprocket in position by using a dial indicator on camshaft sprocket bolt. If end play exceeds .0039" (.10 mm), replace lock plate.

VALVE TIMING				
Engine	INTAKE		EXHAUST	
	Open (BTDC)	Close (ALDC)	Open (BLDC)	Close (ATDC)
All	14°	54°	56°	20°

### ENGINE OILING

**Crankcase Capacity** — 3 $\frac{3}{8}$  quarts (with filter).

**Oil Filter** — Full-flow, replaceable element.

**Oil Pressure** — More than 11 psi (.8 kg/cm<sup>2</sup>) at idle; 54-74 psi (3.8-5.2 kg/cm<sup>2</sup>) at 3000 RPM.

**Pressure Relief Valve** — Nonadjustable, located in oil pump cover.

### ENGINE OILING SYSTEM

Oil is circulated through engine by pressure provided by a trochoid rotor type pump. Oil pump is mounted on side of crankcase and driven by camshaft. Oil is drawn from oil pan by oil pump and into full flow oil filter mounted under oil pump. Oil is then pumped into main oil gallery of crankcase where it is distributed to crankshaft journals, timing chain tensioner and squirter that lubricates timing chain. Oil is circulated from crankshaft main bearing journals to camshaft journals and from center camshaft journal to rocker arm shaft to lubricate rocker arms and valves. Cylinder walls and piston pins are lubricated by oil squirted from squirt hole in connecting rod.

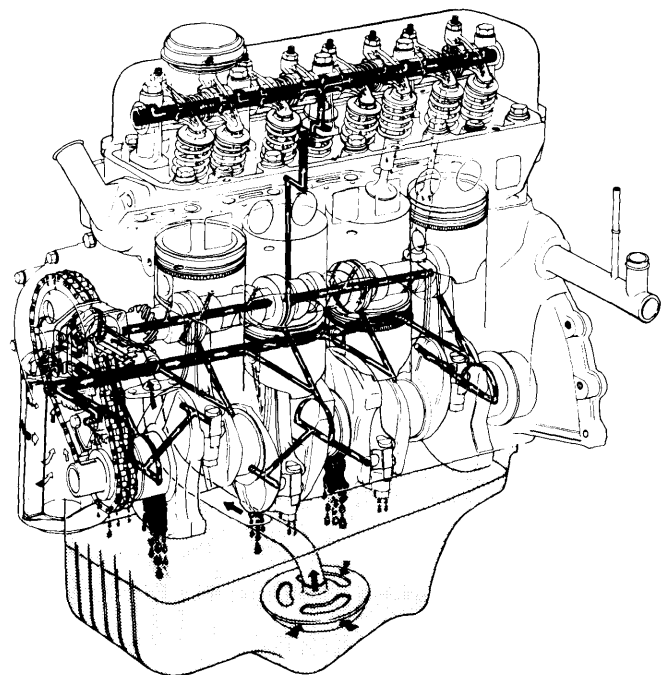

Fig. 15 Engine Oiling System

## B210 & F10 4 CYLINDER (Cont.)

### ENGINE OILING (Cont.)

#### OIL PUMP

Remove pump cover from pump body. Slide outer rotor from pump body. Remove pressure regulator plug, washer, shim, spring, and valve. Thoroughly clean and inspect all components for wear or scoring. Check side and tip clearance

between rotors. Check clearance between outer rotor and pump body. If clearances are excessive, replace components as necessary.

#### Oil Pump Specifications

Application	In. (mm)
Rotor-to-Rotor Side Clearance .....	.002-.0047 (.05-.12)
Rotor-to-Tip Clearance .....	.0016-.0047 (.04-.12)
Rotor-to-Pump Body .....	.0059-.0083 (.15-.21)
Regulator Valve Spring	
Free Length .....	1.71 (43.49)
Pressure Length .....	1.19 (30.3)

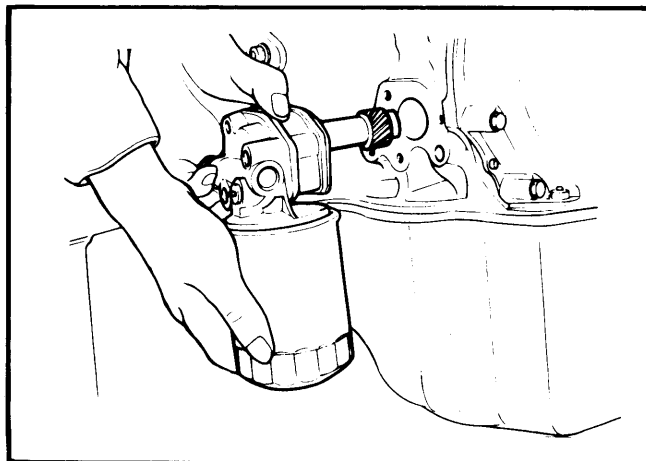

Fig. 16 Removing the Oil Pump

### ENGINE COOLING

#### WATER PUMP

**Removal & Installation** — Drain cooling system and remove fan belt. Remove fan shroud, fan blade, spacer and pulley (or torque coupling). Remove water pump assembly and gasket from front cover. To install, reverse removal procedure.

**Thermostat** — Opens at 177-183°F.

**Cooling System Capacity** — Models with manual transmission hold 6¼ quarts (with heater). Models with automatic transmission hold 6 quarts (with heater).

**Radiator Cap** — 13 psi.

#### TIGHTENING SPECIFICATIONS

Application	Ft. Lbs. (mkg)
Cylinder Head .....	51-54 (7.0-7.5)
Connecting Rod .....	23-27 (3.2-3.8)
Main Bearing Caps .....	36-43 (5.0-6.0)
Camshaft Sprocket .....	29-35 (4.0-4.8)
Camshaft Lock Plate .....	3-4 (0.4-0.5)
Timing Chain Tensioner .....	4.3-5.8 (0.6-0.8)
Front Cover .....	3.6-5.1 (.5-.7)
Oil Pan .....	2.9-4.3 (.4-.6)
Oil Pump .....	6.5-10.1 (.9-1.4)
Rocker Arm Shaft .....	14-18 (2.0-2.5)
Manifolds .....	10.8-14.5 (1.5-2.0)
Crankshaft Pulley .....	108-145 (15-20)
Flywheel .....	54-61 (7.5-8.5)
Oil Strainer .....	6.5-10 (.9-1.4)
Engine Mounts .....	14-18 (1.9-2.5)
Water Pump .....	6.5-10.0 (.9-1.4)