

Courier Engines

PICKUP 4 CYLINDER

GENERAL SPECIFICATIONS										
Year	Displ.		Carburetor	HP at RPM	Torque (Ft. Lbs. at RPM)	Compr. Ratio	Bore		Stroke	
	cu. ins.	cc					in.	mm	in.	mm
1976	109.6	1796	2-Bbl.	8.6-1	3.07	78	3.70	94

ENGINE IDENTIFICATION

Vehicle engine information is stamped on a plate riveted to body at right rear of engine compartment.

Application

All Models VB

Engine Code

ENGINE REMOVAL

- 1) Remove hood and drain cooling system. Remove air cleaner assembly. Disconnect upper radiator hose at engine and lower hose at radiator. Unbolt and remove radiator.
- 2) Disconnect accelerator linkage and fuel line at carburetor. Disconnect linkage from intake manifold, cable at air by-pass valve, choke cable, battery cables, coil wires at distributor and coil lead wires.
- 3) Remove fan, loosen alternator retaining bolts and remove alternator belt. If equipped with Thermactor (air pump), remove mounting bolts and pump drive belt. Remove alternator bracket and adjusting arm bolts and position alternator out of the way. Pull Thermactor hoses off pump, remove bracket and position pump aside. Disconnect heater hoses from intake manifold and Thermactor air hose from by-pass valve.
- 4) Disconnect lead wire and boot from oil pressure sending unit, battery cable from block and wires from starter solenoid. Raise vehicle and drain oil. Remove splash shield and separate exhaust pipe from manifold. Remove clutch housing and bottom starter bolts.
- 5) Lower vehicle, remove upper starter bolts and withdraw starter. Place a floor stand under transmission. Connect a lifting sling to engine hanger brackets. Disconnect engine mounts and pull engine forward until clear of transmission shaft. Lift engine from vehicle. To install, reverse removal procedures.

INTAKE MANIFOLD

Removal - 1) Drain cooling system. Remove air cleaner assembly and accelerator linkage. Disconnect choke cable and fuel line at carburetor.

2) Disconnect Thermactor hoses (if equipped), crankcase ventilation hose, heater return hose and by-pass hose. Remove attaching nuts and lift manifold, with carburetor, off studs.

Installation - To install, reverse removal procedure while noting the following: Clean all gasket surfaces and install a new gasket. Install intake manifold and tighten attaching bolts working from the center of manifold towards each end. Fill cooling system when all components are installed.

CYLINDER HEAD

Removal - 1) Drain cooling system. Remove hood and air cleaner assembly. Disconnect lead wire and vacuum line from distributor. Rotate crankshaft until number one cylinder is at TDC of compression stroke. Remove plug wires and cap from distributor as an assembly. Remove distributor and rocker arm cover.

2) Raise vehicle and disconnect exhaust pipe from manifold. Lower vehicle and remove accelerator linkage. Disconnect temperature sending wire, throttle cable at air by-pass valve, choke cable and fuel line from carburetor.

3) Disconnect Thermactor hoses (if equipped), heater return hose at intake manifold, by-pass hose, water pump hose, and upper radiator hose at engine. Disconnect lead wire from slow fuel valve. Remove intake manifold bracket and lower front cylinder head bolt.

4) Remove nut, washer and distributor gear from camshaft, then remove nut, washer and camshaft sprocket. Remove cylinder head bolts. Remove rocker arm assembly and camshaft. Lift head assembly off of engine block. Relieve tension from timing chain by removing tensioner cover and loosening tensioner attaching bolts.

Installation - To install, reverse removal procedure while noting the following: Clean all gasket surfaces and use new gaskets upon installation. Install cylinder head and tighten bolts to specifications in sequence as shown in illustration.

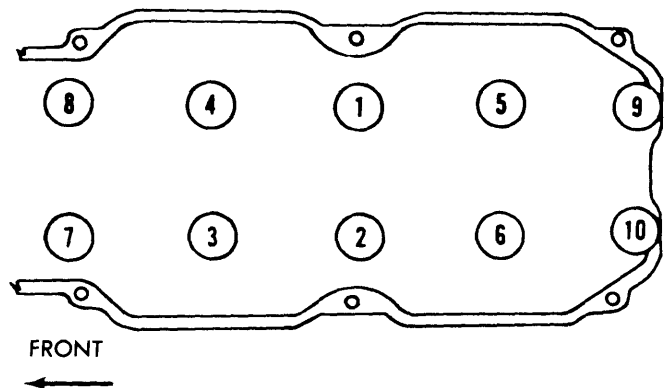

Fig. 1 Cylinder Head Tightening Sequence

PICKUP 4 CYLINDER (Cont.)

VALVES							
Engine & Valve	Head Diam. In. (mm)	Face Angle	Seat Angle	Seat Width In. (mm)	Stem Diameter In. (mm)	Stem Clearance In. (mm)	Valve Lift In. (mm)
1796 cc Int.	1.6496-1.6575 (41.90-42.10)	45°	45°	.055 (1.397)	.3161-.3167 (8.029-8.044)	.0007-.0021 (.017-.053)
Exh.	1.2953-1.3031 (32.90-33.09)	45°	45°	.055 (1.397)	.3159-.3167 (8.024-8.044)	.0007-.0023 (.017-.058)

VALVE ARRANGEMENT

Intake - Left side.

Exhaust - Right side.

VALVE GUIDE SERVICING

Check guides for wear or damage, replace as necessary. With valves removed, using suitable tool (T72J-6510), drive valve guides out top of cylinder head. Install new guides, making sure exhaust and intake guides are in proper locations. Drive guide in until ring around guide touches head.

VALVE STEM OIL SEALS

With valves and springs removed, pull oil seals off valve guides using suitable tools (T72J-6571 and T59L-100-B). Install new seals on valve guides with large diameter hole facing cylinder head.

VALVE SPRINGS			
Engine	Free Length In. (mm)	PRESSURE Lbs. @ In. (kg @ mm)	
		Valve Closed	Valve Open
1796 cc Inner	1.438 (36.52)	16.3@1.30 (7.4@33.0)
Outer	1.469 (37.31)	26.8@1.36 (12.2@34.5)

VALVE SPRINGS

Removal - With cylinder head removed from engine proceed as follows: Compress valve springs and remove retainer locks. Release springs and remove spring retainers, springs, and valves. **NOTE** - Identify all valve components for installation into original positions. Exhaust and intake retainers must be installed in original position to prevent premature valve failure.

Installation - Lubricate valves, valve stems and valve guide with engine oil. Apply Lubriplate to valve tips. Install new valve oil seals on valve guides and install valves in guide from which it was removed. Install valve springs and retainer. Compress springs and install retainer locks. Release springs and install cylinder head.

VALVE SPRING INSTALLED HEIGHT

Check valve spring pressure at specified height, replace if not within specifications. Measure free length of spring, if not within three percent, replace spring. Using a square, check that spring is not more than $\frac{1}{16}$ " out-of-square.

ROCKER ARM ASSEMBLY

1) Remove front bearing cap from rocker shafts. Slide rocker arms, springs, supports and bearing caps (with oil pipe) off both shafts, keeping parts in order for reassembly.

2) Remove oil pipe from bearing caps. Remove camshaft thrust plate from front bearing cap, if necessary. Prior to reassembly, lubricate arms and shafts with heavy (MS) motor oil. When installing shafts in intake side, ensure ends with longer length between oil hole and tip are turned inward, toward each other. Make sure "O" ring on oil pipe is centered in middle bearing cap passage.

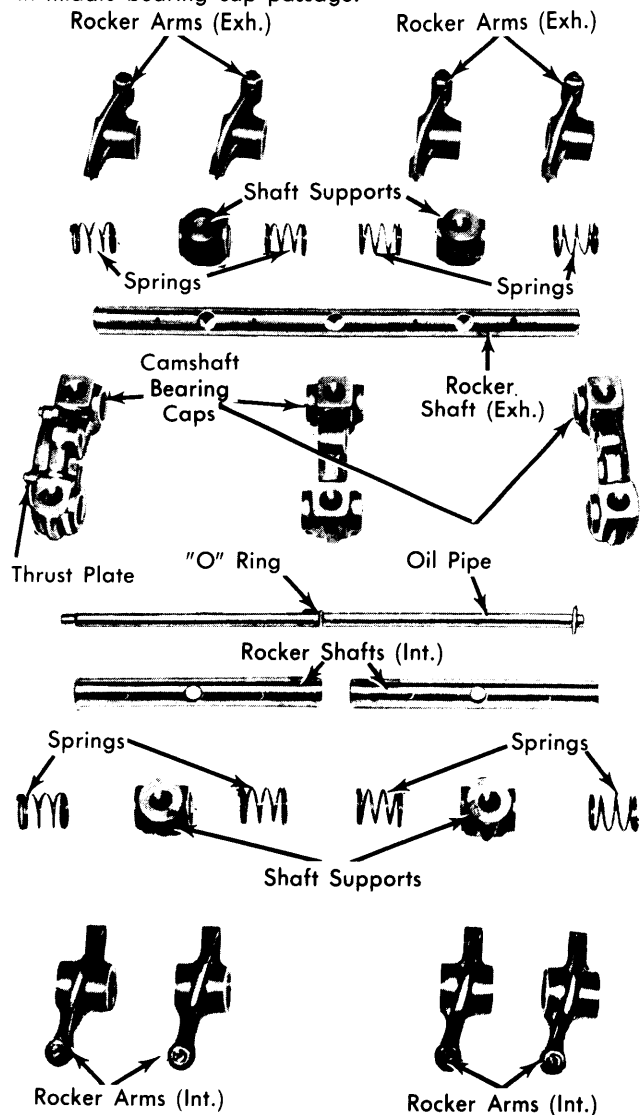

Fig. 2 Exploded View of Rocker Arm & Shaft Assembly

PICKUP 4 CYLINDER (Cont.)

VALVE CLEARANCE ADJUSTMENT

1) With engine at normal operating temperature, rotate crankshaft until number one piston is at TDC of compression stroke. Check clearance with feeler gauge at either camshaft or valve.

2) Clearance must be .012" (.305 mm). If not within specifications, loosen adjusting screw lock nut and turn adjusting screw with feeler gauge in place. Hold screw in position and tighten lock nut. Adjust valves in firing order sequence; 1-3-4-2.

PISTONS, PINS, RINGS						
Engine	PISTONS	PINS		RINGS		
	Clearance In. (mm)	Piston Fit In. (mm)	Rod Fit In. (mm)	Rings	End Gap In. (mm)	Side Clearance In. (mm)
1796 cc	.0022-.0028 (.056-.071)	.0002-.0006 (.005-.015)	.0004-.0012 (.010-.030)	1.	.008-.016 (.203-.406)	.0014-.0028 (.036-.071)
				2	.008-.016 (.203-.406)	.0012-.0025 (.030-.064)
				Oil	.008-.016 (.203-.406)	.0012-.0024 (.030-.061)

OIL PAN

Removal — Raise vehicle on hoist and remove front splash shield. Drain crankcase, remove clutch release cylinder attaching nuts and position cylinder to one side. Remove the engine rear brace attaching bolts and loosen bolts on left side. Disconnect emission line from oil pan. Remove oil pan attaching nuts and bolts, and lower oil pan onto crossmember. Remove oil pump pick-up tube, and remove oil pan from vehicle.

Installation — To install, reverse removal procedure while noting the following: Clean all gasket surfaces and use new gaskets upon installation. Ensure that oil pump pick-up tube and screen are clean before installing.

PISTON & ROD ASSEMBLY

Removal — 1) With cylinder head and oil pan removed, remove oil pump. Rotate crankshaft until piston to be removed is at bottom of travel. Place a cloth on piston to collect cuttings, then using a ridge reamer, remove any ridge or deposits from upper end of cylinder. **NOTE** — Do not cut into ring travel area in excess of $\frac{1}{32}$ ".

2) Make sure connecting rod caps are marked so they may be replaced in their original positions, then remove rod caps. Push piston and rod assembly out top of cylinder. Take care not to damage bearing journal.

Installation — Oil piston rings, pistons and cylinder walls with engine oil. With rings properly spaced, install ring compressor onto piston. Install piston and rod assembly into its original bore. Make sure connecting rod marks are facing left side of engine and "F" mark on piston is facing forward (see illustration). Install rod caps and tighten rod bolts.

FITTING PISTONS

1) Determine piston-to-cylinder bore clearance. Check cylinder for out-of-round or taper. Fit new pistons if necessary. Pistons are available in .010", .020", .030" and .040" oversizes.

2) Place rings in cylinder near bottom of bore and measure end gaps. Place rings on piston and measure side clearance. If high steps have developed on lower back side of ring lands replace piston.

3) Place rings on piston with end gaps 120° apart so that no gap is located on thrust face or piston pin bore. Using suitable ring compressor, install piston in proper bore with "F" marking facing forward.

PISTON PINS

Piston pins are removed using an arbor press, pilots and driver. Measure pin and connecting rod diameters to ensure proper fit.

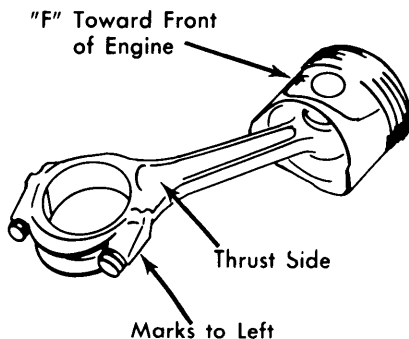

Fig. 3 Piston & Rod Assembly Installation Features



Fig. 4 Measuring Piston Ring Gap

PICKUP 4 CYLINDER (Cont.)

CRANKSHAFT MAIN & CONNECTING ROD BEARINGS							
Engine	MAIN BEARINGS				CONNECTING ROD BEARINGS		
	Journal Diam. In. (mm)	Clearance In. (mm)	Thrust Bearing	Crankshaft End Play In. (mm)	Journal Diam. In. (mm)	Clearance In. (mm)	Side Play In. (mm)
1796 cc	2.4779-2.4785 (62.93-62.95)	① .0005-.0015 (.013-.038)	5	.003-.01 (.076-.254)	2.0842-2.0848 (52.938-52.954)	① .001-.0011 (.025-.028)	.004-.008 (.102-.203)
		② .0012-.0024 (.030-.061)				② .001-.003 (.025-.076)	

① - Desired.

② - Allowable.

MAIN & CONNECTING ROD BEARINGS

1) Inspect each bearing for scored, chipped or worn surface and replace if condition exists. If copper base is visible through bearing overlay, replacement is not necessary, if within specifications.

2) When installing new bearings, fit bearings to minimum specified clearance. Use Plastigage method to determine bearing clearances. Inserts are available in .010", .020" and .030" undersizes.

THRUST BEARING ALIGNMENT

Push crankshaft to one side to take up end play. Insert a feeler gauge between thrust washers and crankshaft. Replace thrust washers if measurement is not within specifications. Install new thrust washers with oil groove facing crankshaft thrust side.

REAR MAIN BEARING OIL SEAL

NOTE - If rear main bearing seal replacement is only operation being performed, it can be done in vehicle; however if it is being replaced in conjunction with rear main bearing, engine must be removed.

Remove transmission and clutch assembly. Using an awl, punch two holes in seal and install sheet metal screws. Using a pair of levers, pry out old seal. Press in new seal, reinstall clutch and transmission.

ENGINE FRONT COVER

Removal - 1) Remove hood and drain cooling system. Disconnect upper radiator hose at engine and lower hose at radiator. Remove radiator, drive belts, crankshaft pulley, and water pump. Remove cylinder head to front cover bolt. Raise vehicle and remove front splash shield.

2) Disconnect emission line from oil pan. Remove oil pan. Lower vehicle, remove alternator bracket to block bolts and position alternator to one side. Remove thermactor pump to block bolts and position to one side. Remove steel tube bolts and tube from front of engine. Remove attaching bolts for front cover and remove front cover.

Installation - To install engine front cover, reverse removal procedure.

FRONT COVER OIL SEAL

Drain cooling system, disconnect radiator hoses and remove radiator. Loosen alternator and Thermactor attaching bolts (if equipped). Remove drive belts. Remove crankshaft pulley, then pull seal from shaft, using suitable tool (T72J-6700). Install new seal using suitable tool (T72J-6700-A). Reverse removal procedures for remaining components.

CAMSHAFT			
Engine	Journal Diam. In. (mm)	Clearance In. (mm) ①	Lobe Lift In. (mm)
1796 cc	Front	1.7695-1.7701 (44.945-44.960)	.0007-.0027 (.018-.069)
	Center	1.7691-1.7697 (44.935-44.950)	.0011-.0031 (.028-.079)
	Rear	1.7695-1.7701 (44.945-44.960)	.0007-.0027 (.018-.069)

① - End play is .001-.007" (.025-.178 mm).

② - See Cam Lobe Lift procedure.

TIMING CHAIN

Removal - 1) Remove cylinder head and front cover. Remove oil pump gear attaching nut, oil pump-to-block attaching bolts and loosen gear on the pump. Remove oil pump, gear and oil pump chain.

2) Remove timing chain tensioner and loosen timing chain guide strip screws. Remove oil slinger. Remove outer gear (for oil pump chain) from crankshaft. Remove timing chain and crankshaft gear.

Installation - 1) Position crankshaft inner sprocket into timing chain, then install sprocket and chain onto crankshaft. Install oil pump with gear onto cylinder block. Install oil pump chain and outer sprocket to crankshaft while positioning chain onto oil pump gear. Install timing chain tensioner. See *Timing Chain Tensioner*. Do not release snubber spring tension. Install cylinder head and camshaft to cylinder block.

NOTE - Do not install rocker arm assembly at this time.

2) Obtain correct timing chain alignment referring to *Timing Chain Alignment* illustration and using the following

Courier Engines

PICKUP 4 CYLINDER (Cont.)

procedure: Rotate crankshaft to TDC of compression stroke on number one cylinder. This will place crankshaft with keyway facing straight up. Position camshaft with keyway facing straight up. Timing chain must now be positioned on camshaft sprocket so single plated link is aligned with timing mark on right-hand side of camshaft sprocket at rocker arm cover joint face, while facing engine. The two plate links on timing chain must straddle timing mark on BDC of crankshaft sprocket.

3) Install rocker arm shaft assembly, cylinder head bolts, and tighten all bolts to specifications. Adjust timing chain tension. See *Timing Chain Tension*. Release tensioner snubber and install front cover. Install remaining components in reverse of removal procedure and adjust valve clearance.

TIMING CHAIN TENSION

1) Remove crankshaft pulley and water pump. Remove cover from tensioner. Rotate crankshaft slightly in direction of engine rotation. Lift release on tensioner and compress snubber spring fully. Install wedge in tensioner so it will not release.

2) Remove two access plugs and aluminum washers from holes in timing chain cover and side of head. Loosen guide strip attaching screws. Press top of strip with lever inserted through access hole in head.

3) Tighten guide strip attaching screws with screwdriver inserted through hole in cover. Remove wedge from tensioner, allowing snubber to take up chain slack.

4) Install access plugs and aluminum washers to their respective holes. Replace chain tensioner cover and gasket. Install water pump and crankshaft pulley. Tighten bolts and adjust belt tension.

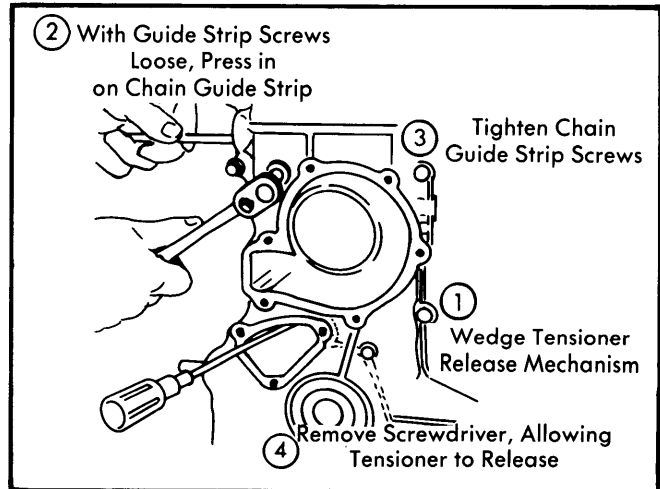

Fig. 6 Adjusting Timing Chain Tension

OIL PUMP CHAIN

Check oil pump chain for excessive deflection as shown in illustration. If deflection is more than .157" (3.97 mm), install adjusting shims between cylinder block and oil pump body.

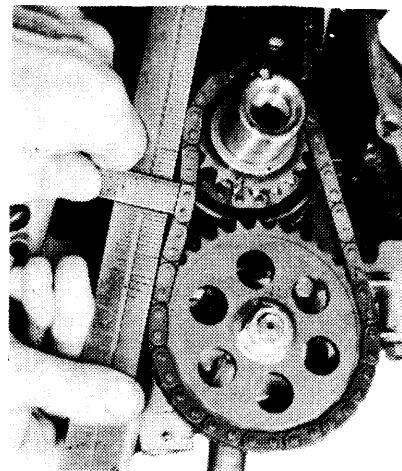

Fig. 7 Measuring Oil Pump Chain Deflection

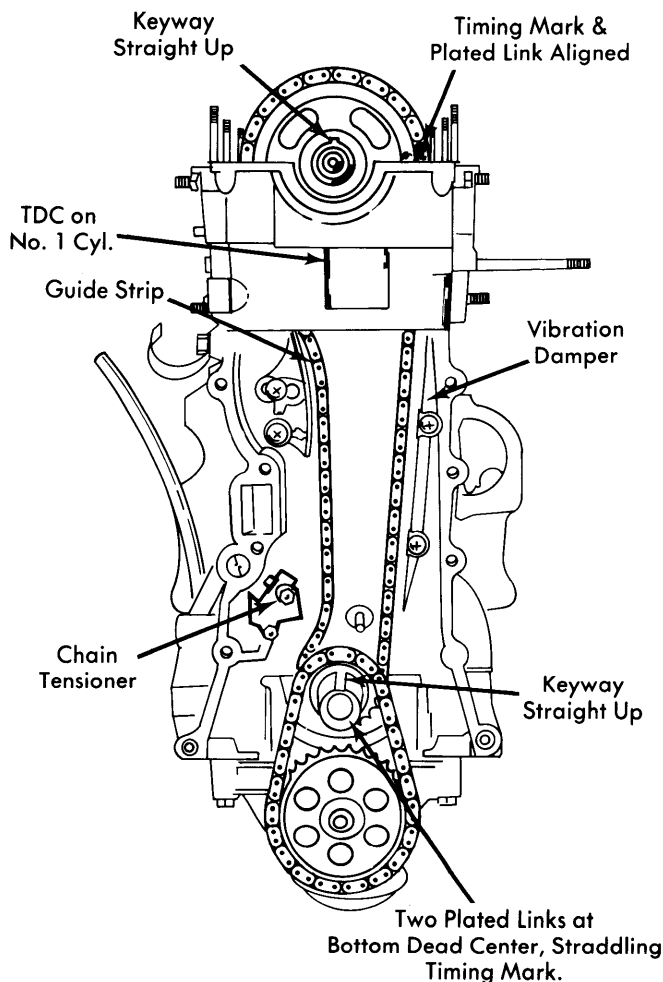

Fig. 5 Timing Chain & Sprocket Alignment

CAMSHAFT

Removal - 1) Remove hood and water pump. Disconnect vacuum line and lead wire from distributor. Rotate crankshaft to position number one cylinder on TDC of compression stroke. Remove plug wires and distributor cap as an assembly, then remove distributor from engine. Remove rocker arm cover.

2) Remove crankshaft pulley, then remove cover from timing chain tensioner. Lift release on tensioner and compress

PICKUP 4 CYLINDER (Cont.)

snubber spring fully. Wedge a screwdriver in the tensioner to keep spring compressed. Remove cylinder head bolts and rocker arm assembly.

3) Remove nut, washer, and distributor gear from camshaft. Remove camshaft gear attaching nut and washer. Carefully remove camshaft from gear and engine block. **NOTE** — Do not remove camshaft gear from timing chain and ensure that gear teeth-to-chain relationship is not disturbed.

Installation — To install, reverse removal procedure while noting the following: When installing camshaft to gear take care not to disturb gear-to-chain relationship. Adjust timing chain tension. Check camshaft end play. Adjust valve clearance.

CAMSHAFT BEARINGS

Remove camshaft and inspect bearings for wear or damage. Use Plastigage method to determine clearance. Replace bearings which do not meet specifications.

CAMSHAFT END THRUST

Check camshaft end play with a feeler gauge inserted between thrust plate and camshaft flange. End play should be checked at time of overhaul, before gear and sprocket are replaced.

CAM LOBE LIFT

Remove rocker arm cover. Measure distance between major and minor diameters (see illustration) of each lobe with a Vernier caliper. Difference between diameters of each cam is lobe

lift. If lobe lift loss exceeds .008" (.20 mm), replace camshaft. Check lift of each lobe in consecutive order and note each reading.

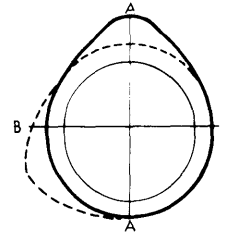

Fig. 8 Measuring Camshaft Base Circle and Lobe Lift

VALVE TIMING				
Engine	INTAKE		EXHAUST	
	Open (BTDC)	Close (ALDC)	Open (BLDC)	Close (ATDC)
1796 cc	13°	57°	62°	8°

VALVE TIMING

Rotate crankshaft and camshaft until keyways are straight up. Place timing chain on camshaft sprocket so single plated link is aligned with timing mark on right-hand side of camshaft sprocket at rocker arm cover joint face, while facing engine. The two plate links on timing chain must straddle timing mark on BDC of crankshaft sprocket. Crankshaft in this position will be TDC of number one cylinder.

ENGINE OILING

Crankcase Capacity — 4 qts. (Add 1 qt. with filter change).
Oil Filter — Disposable type.
Oil Pressure — 50-64 psi @ 3000 RPM; 4.25 psi @ idle.

Remove outer race. Remove cotter pin from body, pull cap out of chamber, and take out spring and plunger.

ENGINE OIL SYSTEM

Rotor type oil pump is chain driven by crankshaft. Timing chain is lubricated by oil jet in cylinder block and oil holes in slipper head of adjuster. Oil holes in large end of connecting rods align with oil holes in crankshaft to lubricate pistons and components.

2) Assemble in reverse order. Rotor, shaft and outer race are serviced as an assembly. If one component is damaged, replace all three. Install new cotter pin and gasket. Prime pump with oil before installing unit in block.

OIL PUMP

1) Remove oil inlet tube from pump. Remove and discard gaskets. Remove cover, withdraw inner rotor and shaft assembly.

Oil Pump Specifications	
Application	Clearance In. (mm)
Lobe-to-Lobe002-.006 (.051-.152)
Rotor End Clearance.....	.002-.004 (.051-.102)
Outer Rotor-to-Housing006-.010 (.152-.254)

Courier Engines

PICKUP 4 CYLINDER (Cont.)

ENGINE COOLING

Thermostat – Begins to open at 180°F; fully open 203°F.

Cooling System Capacity – 7½ qts. (includes heater).

Radiator Cap – 13 psi.

WATER PUMP

Remove hood and drain cooling system. Remove lower hose from water pump, disconnect upper radiator hose at engine and lower hose at radiator. Remove radiator from vehicle. Loosen alternator and Thermactor pump (if equipped). Remove drive belt(s), fan, and pulley. Remove crankshaft pulley. Remove water pump. To install, reverse removal procedure.

TIGHTENING SPECIFICATIONS

Application	Ft. Lbs.(mkg)
Main Bearing Caps	60-65(8.3-9.0)
Connecting Rod Caps	30-33(4.1-4.6)
Cylinder Head	
Cold	63-68(8.7-9.4)
Hot	69-73(9.5-10.1)
Oil Pan	5-9(.7-1.2)
Flywheel	112-118(15.5-16.3)
Distributor Drive Gear	57(7.9)
Oil Pump-to-Block	13-20(1.8-2.8)
Camshaft Sprocket	51-64(7.1-8.8)
Rocker Arm Cover	1-2(.1-.3)
Oil Pump Sprocket	22-26(3.0-3.6)
Intake Manifold	14-19(1.9-2.6)
Exhaust Manifold	16-21(2.2-2.9)