

2000 cc 4 CYLINDER

GENERAL SPECIFICATIONS										
Year	Displ.		Carburetor	HP at RPM	Torque (Ft. Lbs. at RPM)	Compr. Ratio	Bore		Stroke	
	cu. ins.	cc					in.	mm	in.	mm
1976	121.7	2000	2-Bbl.	8.5:1	3.31	84	3.54	90

ENGINE IDENTIFICATION

Engine model code number is stamped on the left side of the engine block just below the starter. Engine serial number is stamped on right side of block on a flat just forward of the manifold. Numbers are decoded as follows:

Application C.I.D. (cc)	Serial Number	Model Code
121.7(2000) 52A00101-52Z99999 4G52

ENGINE REMOVAL

1) Drain cooling system, remove battery, disconnect ground strap, wiring from ignition coil, vacuum control solenoid valve, fuel cut-off solenoid valve, generator, starter, transmission switch, back-up light switch, water temperature gauge and oil pressure switch.

2) Remove air cleaner and disconnect attaching hoses. Disconnect accelerator linkage and heater hoses. Unbolt and separate exhaust pipe from manifold. Disconnect pipe mounting bracket at transmission.

3) Disconnect hose between fuel filter and fuel pump return pipe. Remove radiator and radiator shroud. If equipped with automatic transmission, remove oil cooler pipe and tie rod when removing radiator.

4) Remove console box, then detach control lever assembly from transmission. Remove hood. Disconnect speedometer cable and back-up light switch wiring from transmission. Disconnect clutch cable from shift lever and then disconnect cable from its bracket (if equipped with manual transmission). Drain transmission. If equipped with transmission dynamic vibration damper, remove damper, remove locking bolts for attaching flange yoke at rear of propeller shaft, then draw shaft out of transmission.

5) Support transmission on a suitable jack and remove front and rear mount bolts. Remove rear engine support bracket. Attach suitable lifting device to front and rear engine hangers. Lift engine-transmission assembly obliquely upward and out of engine compartment. **NOTE** - Keep transmission lower than engine when removing.

INTAKE MANIFOLD

Removal & Installation - Drain cooling system, remove air cleaner assembly, water outlet hose, heater hoses, accelerator linkage and choke cable. Disconnect vacuum line, fuel line, water hose on carburetor side, and wiring for water temperature gauge. Remove carburetor, and then remove intake manifold. To install, reverse removal procedure and tighten all nuts and bolts.

CYLINDER HEAD

Removal - 1) Remove rocker arm cover. Turn crankshaft until No. 1 piston is at top of its compression stroke. **NOTE** - If dowel pin at forward end of camshaft is at position shown in illustration when crankshaft pulley notch is aligned with timing mark "T" at front of timing chain case, then No. 1 piston is at TDC.

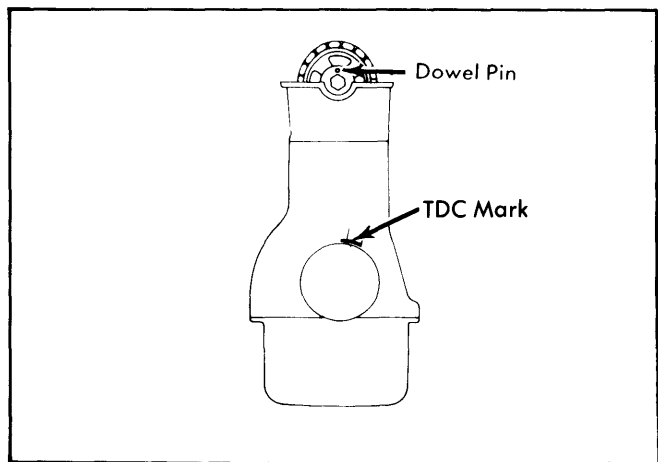

Fig. 1 Setting No. 1 Piston at TDC

2) Draw a mating mark in white paint on timing chain in line with mating mark on camshaft sprocket. Remove camshaft sprocket. Unscrew cylinder head bolts and nuts according to illustrated loosening sequence. **CAUTION** - Loosen head bolts in two or three stages in order to prevent head warping. Note dowel locator pins when removing head, and take care not to damage pins or twist chain when lifting off head.

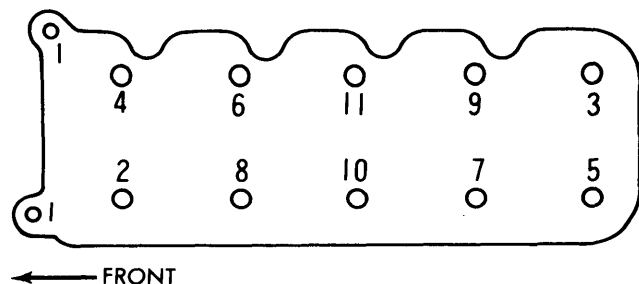

Fig. 2 Cylinder Head Loosening Sequence

Arrow & Colt Engines

2000 cc 4 CYLINDER (Cont.)

Installation - 1) To install, reverse removal procedure, noting the following: Apply sealant to points at which cylinder head gasket will rest over junction of front cover chain case and cylinder block.

2) Tighten cylinder head bolts in sequence shown and in three or four stages. Install camshaft sprocket onto camshaft while pulling upward. If installation is difficult, slacken chain tensioner as required. Turn crankshaft back about 90°. Tighten sprocket lock bolt. Adjust valve clearance.

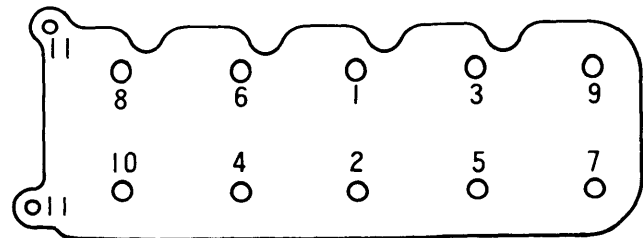

Fig. 3 Cylinder Head Tightening Sequence

VALVES							
Engine & Valve	Head Diam. In. (mm)	Face Angle	Seat Angle	Seat Width In. (mm)	Stem Diameter In. (mm)	Stem Clearance In. (mm)	Valve Lift In. (mm)
2000 cc Intake	1.65 (41.9)	45°	45°	.035-.051 (.89-1.3)	.315 (8.0)	.001-.0022 (.025-.056)
Exhaust	1.34 (34.0)	45°	45°	.035-.051 (.89-1.3)	.315 (8.0)	.002-.0033 (.051-.084)

VALVE ARRANGEMENT

Intake - Left side.
Exhaust - Right side.

ROCKER ARM & CAMSHAFT ASSEMBLY

Removal - Remove camshaft bearing cap nuts. Holding assembly by front and rear caps, lift rocker arm shaft off head. Disassemble individual components, keeping rocker arms and corresponding components in proper sequence for reassembly. Remove camshaft from cylinder head.

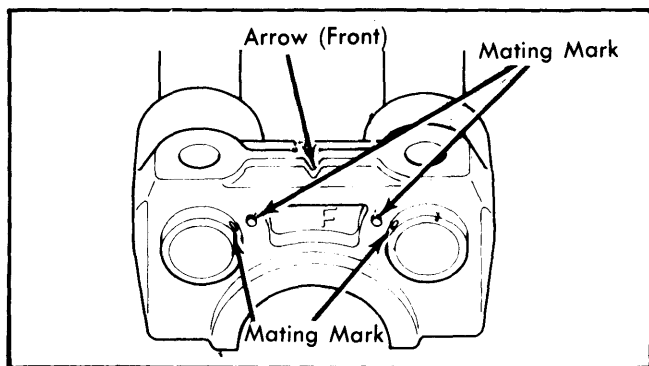

Fig. 4 Location of Rocker Shaft Mating Marks

Installation - 1) Install camshaft on head after completing servicing described within this article. See *Camshaft*. Install caps, rocker arms, springs, and wave washers onto both rocker arm shafts. **NOTE** - The front bearing cap has embossed mating mark on front side, which should be aligned with indent marks on front end of rocker arm shafts. Each cap also has arrow which marks direction of installation (front). Ensure all parts are returned to their original positions. Right side rocker arm shaft has eight oil holes and left side has four holes.

2) Install assembled rocker arm shaft assemblies to cylinder head. Be sure that dowel pin is directly on top of camshaft. Tighten caps in following order: 3, 2, 4, front, and rear. **NOTE** - No. 4 and front caps are to be tightened together with the valve cover bracket.

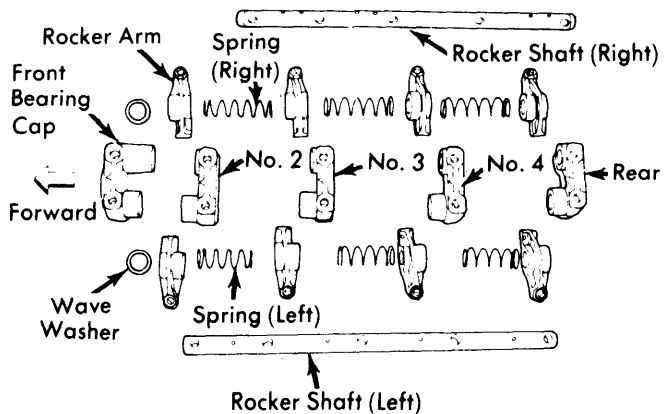

Fig. 5 Exploded View of 2000 cc Engine Rocker Arm & Shaft Components.

VALVE GUIDE SERVICING

1) Check valve stem-to-guide clearance, and if clearance exceeds service limits as listed in table, replace valve guide with next oversize component. Guides are available in the following oversizes:

Valve Guide Oversizes

Size Mark	Guide Size In. (mm)	Cyl. Head Bore In. (mm)
5.....	.002 (.05).....	.5138-.5145 (13.05-13.07)
25.....	.010 (.25).....	.5216-.5224 (13.25-13.27)
50.....	.020 (.51).....	.5315-.5323 (13.50-13.52)

2000 cc 4 CYLINDER (Cont.)

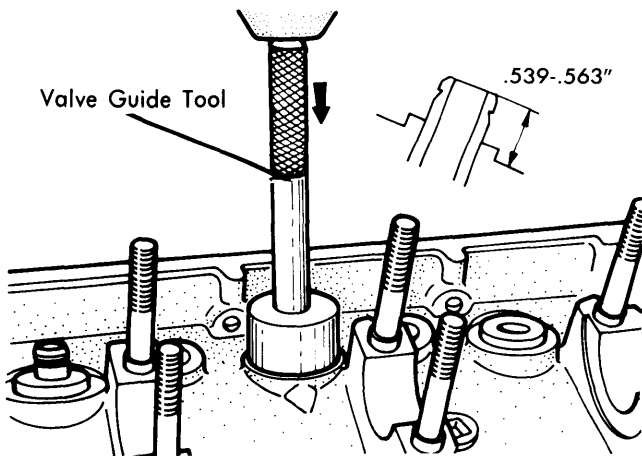

Fig. 6 Valve Guide Installation & Height

2) Heat cylinder head to approximately 480°F (249°C), and then use a suitable valve guide tool to drive out each guide toward the combustion chamber. Ream guide bore in cylinder head to specified size (after head has cooled to room temperature).

3) To install new guides, reheat head to same temperature, quickly insert and drive guides into head. Guide should protrude .539-.563" (13.69-14.30 mm) above head surface, as illustrated. Check guide I.D. and ream as necessary.

VALVE STEM OIL SEALS

After installing valve spring seat, place stem seal on valve guide. Using suitable tool (MD998005), lightly hammer seal into proper position (see illustration). When installing, use care not to twist seal. Do not reuse old seals.

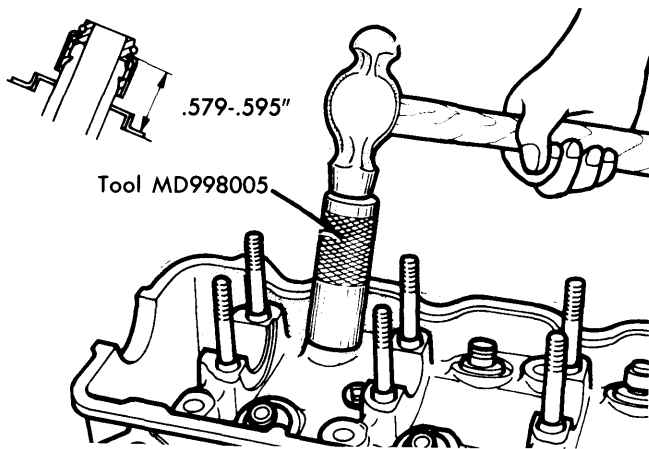

Fig. 7 Valve Stem Oil Seal Installation & Height

VALVE SEAT SERVICING

1) Check valve seat for damage or wear. Replace or rework seat, as necessary. If reworking seat, check valve guide first. Make proper replacement, if required, then check seat for necessary corrections.

2) Recondition valve seat with suitable grinder or cutter to specified contact width. After rework, valve and seat should be lapped with suitable compound.

3) Check valve seat shrinkage by measuring installed height of spring between spring seat and retainer (with all spring components installed). Maximum allowable spring length for both intake and exhaust valve springs is 1.590 (40.39 mm).

4) Remove valve seat by thinning down with a suitable cutter, then machine seat bore to proper size for replacement seat. Heat head to approximately 480°F (250°C) and press in over-size seat. Replacement seats are available in .012" (.305 mm) and .024" (.610 mm) oversizes, marked "30" and "60" respectively.

VALVE SPRINGS			
Engine	Free Length In. (mm)	PRESSURE Lbs. @ In. (kg @ mm)	
		Valve Closed	Valve Open
2000 cc	1.869 (47.4)	61 @ 1.59 (27.67 @ 40.39)

VALVE SPRING

1) With camshaft removed, install spring compressor, remove retainer lock, retainer and spring. Keep components in proper order for reassembly.

2) Install valve spring with enamel identification mark toward rocker arm. Compress spring, making sure spring compressor does not interfere with stem seal. Install retainer and lock.

VALVE SPRING INSTALLED HEIGHT

1) Check free length and tension of each valve spring. If beyond specifications, replace spring. Using a square, check each spring for proper squareness (1.5° or less). Replace spring if excessively out of square.

2) Measure installed height of spring between spring seat and retainer, with spring seat, retainer and retainer lock installed.

VALVE CLEARANCE ADJUSTMENT

1) Ensure timing marks on camshaft sprocket and chain are aligned. With head assembly installed, temporarily adjust valves (sequence for adjustment; 1-3-4-2), according to following procedure: At compression stroke TDC, for cylinder being adjusted, loosen rocker arm nuts, then, turning adjusting screw, adjust valve clearance to specifications.

2) After completion of engine assembly, run engine until coolant temperature is 176°F, then readjust valves.

NOTE — Torque head bolts, with engine warm, prior to final valve clearance adjustment; otherwise, clearance will change if head bolts are torqued last.

Valve Clearance

Application	Cold In. (mm)	Hot In. (mm)
Intake003 (.08)	.006 (.15)
Exhaust007 (.18)	.010 (.25)

Arrow & Colt Engines

2000 cc 4 CYLINDER (Cont.)

PISTONS, PINS, RINGS						
Engine	PISTONS	PINS		RINGS		
	Clearance In. (mm)	Piston Fit In. (mm)	Rod Fit In. (mm)	Rings	End Gap In. (mm)	Side Clearance In. (mm)
2000 cc	.0008-.0016 (.020-.041)	①	Press Fit	No.1	.010-.016 (.25-.41)	.0024-.0039 (.061-.099)
				No.2	.010-.018 (.25-.46)	.0008-.0024 (.020-.061)
				Oil	.010-.018 (.25-.46)	.0008-.0026 (.020-.066)

① - Thumb press fit without rod installed.

PISTON & CONNECTING ROD ASSEMBLY

Removal - Remove cylinder head and oil pan. Check to ensure connecting rods and rod caps are marked to aid in assembling components to their original position. Remove carbon ridge from cylinder bores. Remove connecting rod caps. Remove connecting rod and piston assembly through top of cylinder block.

Installation - To reinstall, lubricate all internal surfaces with engine oil before installation. Make sure front mark on piston head faces front of engine. Use a ring compressor to compress rings (without changing their position) and install piston and connecting rod assembly in to cylinder block in their original position. Tap lightly on piston dome with wooden handle tool while guiding connecting rod onto crankshaft. Install rod cap onto proper piston and connecting rod assembly. Tighten attaching bolts. Install cylinder head and oil pan.

FITTING PISTONS

1) After checking block for distortion (not to exceed .002" or .05 mm), cracks, scratches, or other abnormalities, measure bores at three levels. If any bore distortion exceeds .008" (.20 mm) from standard bore size of 3.3071" (84.00 mm), refinish ALL cylinders and install oversize pistons. The following service replacement pistons are available:

Oversize Pistons

Application ①	Size Mark ②	Diam. In. (mm)
2000 cc		
.010" O.S.	0.25	3.3163 (84.23)
.020" O.S.	0.50	3.3262 (84.49)
.030" O.S.	0.75	3.3360 (84.73)
.039" O.S.	1.00	3.3464 (85.00)

① - Indicates amount of oversize.

② - Stamp mark on piston indicates metric equivalent of amount of oversize.

2) Check outside diameter of piston by measuring at a point .079" (2 mm) from bottom of skirt and at 90° to pin bore. Determine amount of cylinder reboring required to meet specified clearance.

3) To prevent distortion due to the high temperature of the cutting process, this operation should be done in stages and in sequence of 2-4-1-3 or 3-1-4-2. Hone bore to finish size, using a honing angle of 30-45°. Ensure piston-to-cylinder clearance is within specification.

PISTON RINGS

Measure piston ring side and end clearance for all pistons and replace rings as necessary. When replacing a ring without correcting the cylinder bore, check ring end gap at lower part of cylinder that is less worn. When replacing a ring, be sure to use one of the same size. Install rings on piston with end gaps staggered at 120° intervals, but make sure no ring gap is in line with thrust face of pin bore. Also be sure the manufacturer's marks are facing upward when rings are installed.

NOTE - Ensure oil ring gap is opposite the expander joint. The following ring sizes are available:

Piston Ring Sizes

Ring Size	Size Mark
Standard	No Mark
.010" (.25 mm) O.S.	25
.020" (.50 mm) O.S.	50
.030" (.75 mm) O.S.	75
.039" (1.0 mm) O.S.	100

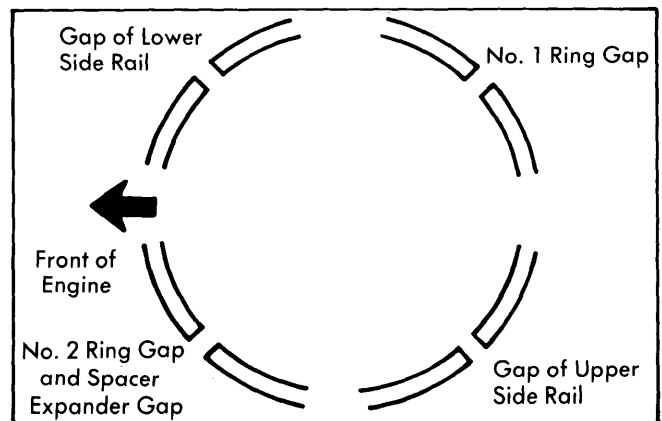

Fig. 8 Piston Ring Gap Positions

PISTON PINS

Check piston pin-to-bore fit; pin should press in smoothly by hand (at room temperature). When assembling, apply engine oil to outside of pin and to piston pin bore, position rod to piston ("FRONT" mark upward), align pin with pressing tool, and press pin into piston and rod.

2000 cc 4 CYLINDER (Cont.)

CRANKSHAFT MAIN & CONNECTING ROD BEARINGS							
Engine	MAIN BEARINGS				CONNECTING ROD BEARINGS		
	Journal Diam. In. (mm)	Clearance In. (mm)	Thrust Bearing	Crankshaft End Play In. (mm)	Journal Diam. In. (mm)	Clearance In. (mm)	Side Play In. (mm)
2000 cc	2.598 (66)	.0008-.0028 (.020-.071)	No.3	.002-.007 (.05-.18)	2.0886 (53.05)	.0006-.0025 (.015-.064)	.004-.01 (.10-.25)

MAIN & CONNECTING ROD BEARINGS

1) Inspect each bearing for peeling, melting, seizure or improper contact. Replace defective bearings. Measure outside diameter of crankshaft and connecting rod journals to determine if out-of-round or tapered.

2) Cut Plastigage to same length as width of bearing. Place it parallel with journal (not over oil holes). Install crankshaft bearings and caps, tightening to specifications. Always install caps with arrow facing forward.

NOTE – Do not turn crankshaft with Plastigage installed.

3) Remove main bearing cap from crankshaft and measure Plastigage at widest part (using scale on Plastigage package). Repeat procedure for connecting rod bearings. If clearance exceeds limits, bearing should be replaced or undersize bearing installed. Undersize bearings are available in .010" (.25 mm), .020" (.50 mm), and .030" (.75 mm) undersizes.

THRUST BEARING

With crankshaft bearing caps installed, check thrust clearance (end play) by inserting feeler gauge between center main bearing and crankshaft thrust face. If clearance exceeds specified limits, replace center main bearing.

CAMSHAFT			
Engine	Journal Diam. In. (mm)	Clearance In. (mm)	Lobe Lift In. (mm)
2000 cc	1.339 (34)	.002-.0035 (.05-.09)

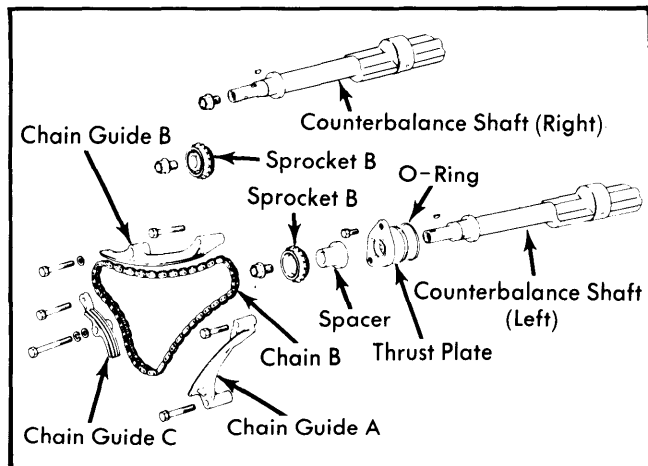

Fig. 9 Exploded View of Silent Shaft Assembly

COUNTERBALANCE SHAFT CHAIN

Removal – With engine removed and placed upside down, remove oil pan and screen. Remove crankshaft pulley, flywheel and timing chain case. Remove chain guides A, B and C (See Fig. 9). Remove sprocket B locking bolts. Remove crankshaft sprocket B, counterbalance shaft sprocket B and chain B.

Installation – To install reverse removal procedure. To adjust tension of chain B, tighten chain guide A mounting bolt. Tighten chain guide C mounting bolt. Shake right and left B sprockets to collect slack at point P (See Fig. 10). Adjust position of chain guide C so when chain is pulled in direction of arrow Y, clearance between chain guide B and links of chain B will be .04-.14" (1.0-3.6 mm). Tighten bolts securely. Install chain case and gasket.

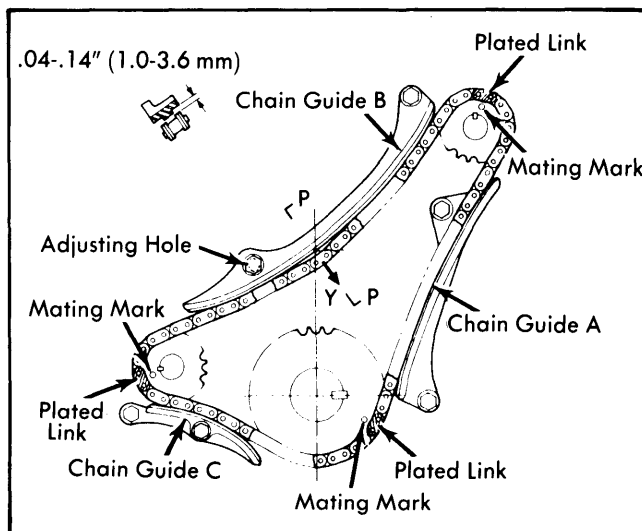

Fig. 10 Adjusting Tension of Chain "B"

TIMING CHAIN

Removal & Installation – With balancer chain removed, remove crankshaft sprocket and camshaft sprocket. Depress timing chain tensioner while removing timing chain. Remove camshaft sprocket holder and right and left timing chain guides. To install, reverse removal procedure.

2000 cc 4 CYLINDER (Cont.)

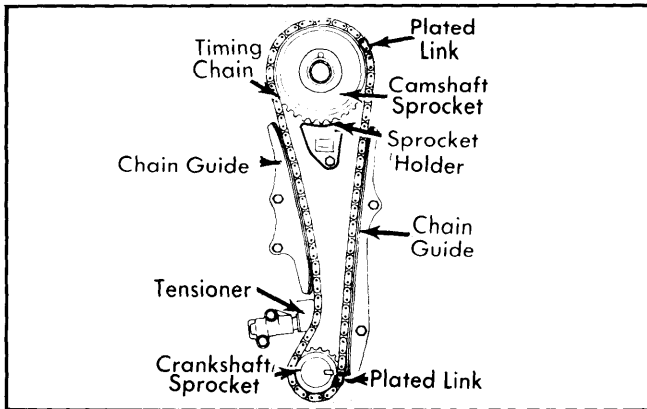

Fig. 11 Timing Chain Alignment & Installation

COUNTERBALANCE SHAFTS

Removal & Installation – 1) With balancer and timing chain removed, proceed as follows: Remove oil pump mounting bolts. Remove bolt locking oil pump driven gear and right counterbalance shaft. Withdraw right counterbalance shaft from cylinder block.

NOTE – If bolt locking oil pump driven gear and counterbalance shaft is hard to loosen, remove oil pump and counterbalance shaft as an assembly. Then remove lock bolt to disassemble.

2) Remove thrust plate supporting front of left counterbalance shaft. (Thrust plate is removed by threading bolts into plate holes at same time). Withdraw counterbalance shaft from cylinder block. To install, reverse removal procedure.

CAMSHAFT

1) With camshaft removed from vehicle, first visually check camshaft for any obvious defects. Attach a dial gauge to No.

2 or No. 3 journal. Turn camshaft one complete revolution and read the total gauge measurement. Divide this amount in half to determine amount of camshaft bend. Maximum allowable bend is .0008" (.020 mm).

2) Next check camshaft end play by measuring with a feeler gauge (camshaft installed) between front bearing cap and camshaft end piece. Play should be .0039-.0079" (.10-.20 mm).

3) Check cam lobes and profile for damage. If lobe height is less than specified, replace camshaft. Wear limit is .020" (.51 mm) less than measurement given in table.

4) Check each camshaft bearing cap for damage. If inner surface is excessively damaged, replace head assembly. Measure each cap I.D. with a dial gauge after installing cap to its appropriate bearing half. Measure camshaft journal diameters, then use these two measurements to determine if camshaft clearance (see table) is within specifications.

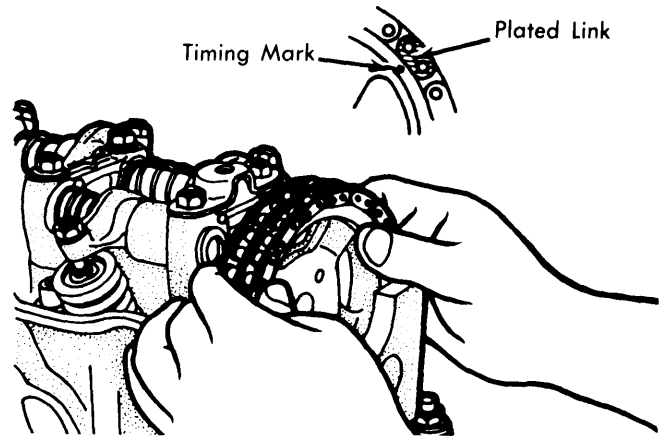

Fig. 12 Camshaft Sprocket Alignment & Installation

ENGINE OILING

Crankcase Capacity – 4.5 quarts

Oil Pressure Switch Operating Pressure – 2.8-5.7 psi (20-40 kg/cm²)

Normal Oil Pressure – 14.2 psi (99.8 kg/cm²), minimum, at idle.

Oil Pump Pressure Relief Valve Opens – 56.9-71.1 psi (400-500 kg/cm²) at 2,000 RPM.

Oil Filter – Full-flow, cartridge type.

ENGINE OILING SYSTEM

Lubrication system is force-feed type, using trochoid gear pump with full-flow filter. Oil pump is driven by pawl located at top end of distributor shaft, which is rotated by crankshaft gear.

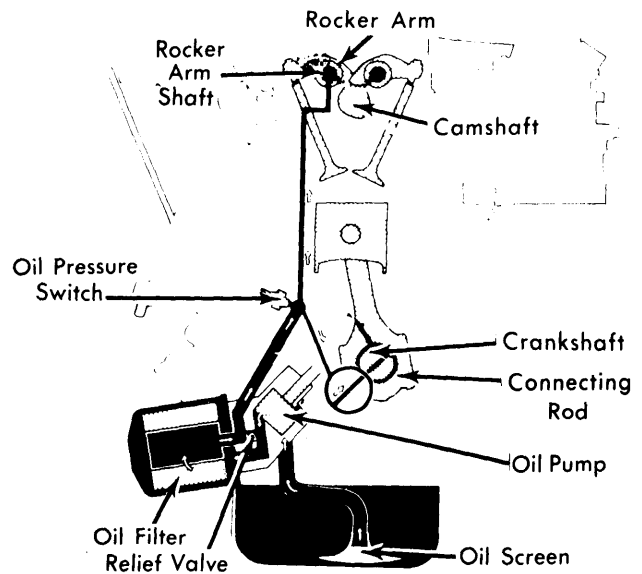

Fig. 13 Cutaway View of Engine Oiling System (1600 cc Shown, 2000 cc Similar)

2000 cc 4 CYLINDER (Cont.)

ENGINE OILING (Cont.)

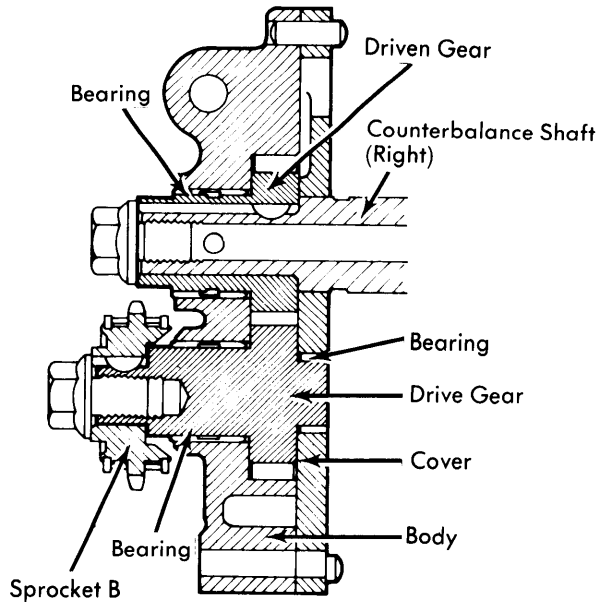

Fig. 14 Cutaway View of Oil Pump

and does not go out of keyway. After installing pump into block, firmly tighten oil pump mounting bolts. Tighten counterbalance shaft and driven gear mounting bolt.

Oil Pump Specifications

Application	Clearance In. (mm)
Gear Teeth-to-Housing0041-.0059 (.104-.150)
Gear End Play0024-.0047 (.061-.119)
Gear-to-Bearing0008-.0047 (.020-.119)
Drive Gear-to-Bearing (Back of Gear)0017-.0026 (.043-.066)

OIL PUMP

Removal — Drain engine oil. Remove oil pan and gasket (discard gasket). Remove bolt locking oil pump drive gear and right counterbalance shaft. Remove oil pump mounting bolts. Withdraw oil pump from cylinder block.

Inspection — Check entire body for cracks and excessive wear. Check gears for ridge wear. Check oil holes and passages for clogging. Check cover for ridge wear. Replace all worn parts. Measure all clearances as shown in Fig. 14.

CAUTION — Prior to installation, fill oil pump with a sufficient amount of engine oil through delivery port.

Installation — **NOTE** — Make sure keyway of oil pump driven gear fits woodruff key at end of counterbalance shaft,

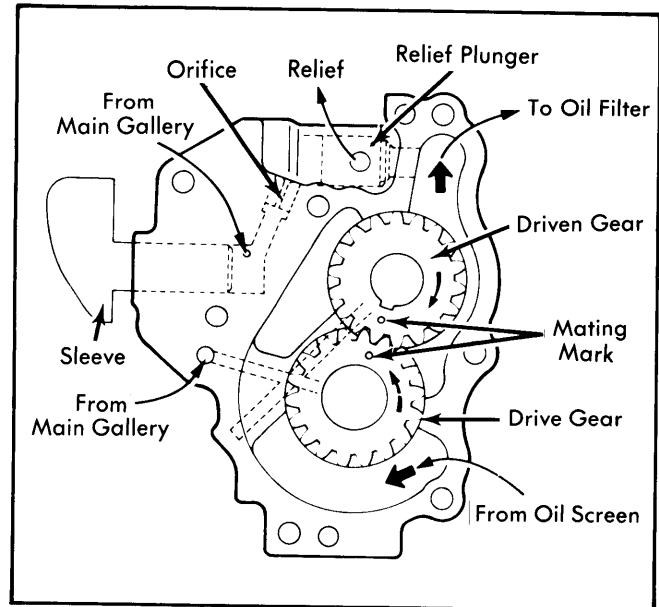

Fig. 15 Mating Marks of Oil Pump Gears

ENGINE COOLING

Thermostat — Opens at 177-183°F (80-84°C). Full open at 203°F (95°C).

Radiator Cap — 13 psi (91.4 kg/cm²).

Cooling System Capacity — 9.5 quarts.

WATER PUMP

Drain coolant, loosen hoses from pump and loosen alternator. Remove fan, pulley, and fan belt. Remove water pump bolts. To install, reverse removal procedure.

TIGHTENING SPECIFICATIONS

Application	Ft. Lbs. (mkg)
Cylinder Block-to-Engine Bracket	29-36 (4.0-5.0)
Engine Support Bracket-to-Body	7.2 (1.0)
Intake & Exhaust Manifolds-to-Head	11-14 (1.5-2.0)
Cylinder Head Bolts	
Cold	65-72 (9.0-10.0)
Hot	72-79 (10.0-11.0)
Camshaft Bearing Cap	13-14 (1.8-1.9)
Camshaft Sprocket	36-43 (5.0-6.0)
Main Bearing Cap	54-61 (7.5-8.4)
Connecting Rod Cap	33-35 (4.6-4.8)
Flywheel-to-Crankshaft	83-90 (11.5-12.4)
Crank Pulley	80-93 (11.0-12.9)
Tensioner Holder	36-43 (5.0-6.0)