

MG MIDGET

MG Midget

DESCRIPTION

Rear axles are hypoid design with center line of pinion set below centerline of ring gear. The axle shafts, pinion and differential assemblies can be serviced without removing axle from vehicle. All differential adjustments are performed using shims. No adjustment for axle shaft end play is necessary.

AXLE RATIO & IDENTIFICATION

Only one basic axle design is used on these models. To determine axle ratio, divide number of ring gear teeth by number of pinion gear teeth.

REMOVAL & INSTALLATION

AXLE SHAFTS & BEARINGS

1) With rear of vehicle raised and wheels removed, release handbrake and back off brake shoe adjusters. On models with disc wheels, remove brake drum locating screws and tap drums off hubs. Remove axle shaft retaining screw and withdraw shaft from hub assembly.

2) Using suitable tool, remove hub nut and lock washer. Withdraw hub complete with bearing and seal. To install, repack hub bearings with grease and press hub into position. If paper washer or "O" ring was damaged on disassembly, they must be replaced. If seal was removed, drift it into position using suitable tool. Drift hub into axle housing using suitable tools and reinstall remainder of components in reverse of disassembly procedure.

PINION FLANGE & SEAL

1) Mark propeller shaft and pinion flange for proper realignment and disconnect propeller shaft. Unscrew nut in center of flange, using suitable tool to prevent flange from rotating. Remove nut and washer and withdraw flange and pressed end cover from pinion shaft. Extract oil seal from axle housing.

2) Press new seal into axle housing with edge of sealing ring facing inwards. Replace flange and end cover, taking care not to damage edge of oil seal. Tighten pinion flange nut and reconnect propeller shaft, ensuring that index marks are lined up.

DIFFERENTIAL CARRIER

Drain rear axle and remove axle shafts. Mark propeller shaft and pinion shaft for correct reassembly and disconnect shaft. Remove nuts securing differential carrier to axle housing and withdraw complete carrier. To install, reverse removal procedure.

OVERHAUL

DISASSEMBLY

1) Check that differential bearing caps are marked to ensure correct replacement, then remove bearing cap nuts, washers and caps. Remove differential cage. Remove differential bearings from cage using suitable tools and noting that shims are installed between inner ring of each bearing and differential cage. Bend tabs back on locking washers and unscrew bolts securing ring gear to differential cage, then remove ring gear.

2) Tap out pin locating differential pinion shaft from ring gear side of cage as tapered pins are used. Drive out differential pinion shaft and remove pinions and thrust washers from cage. Remove pinion nut, flange and pressed end cover. Drive pinion shaft towards rear through carrier. Pinion shaft will come out with inner race and rollers for rear bearing, leaving outer race and complete front bearing in position.

3) Tap out inner race of front bearing and oil seal. Withdraw outer races using suitable tools. Slide off pinion sleeve and shims. Withdraw rear bearing inner race from pinion shaft using suitable tools. Note spacing washer against pinion head. Remove rear bearing outer race using suitable tools.

INSPECTION

Clean and inspect all components for worn or damaged parts. The ring and pinion gear must be replaced as a matched set if replacement of either is necessary.

REASSEMBLY & ADJUSTMENT

Drive Pinion Depth – 1) Install outer bearing races in carrier using suitable tools. Smooth off pinion head with an oil-stone, taking care not to remove any markings etched on head. Assemble pinion and rear bearing with a washer of known thickness behind pinion head. Position pinion in carrier without bearing spacer and oil seal.

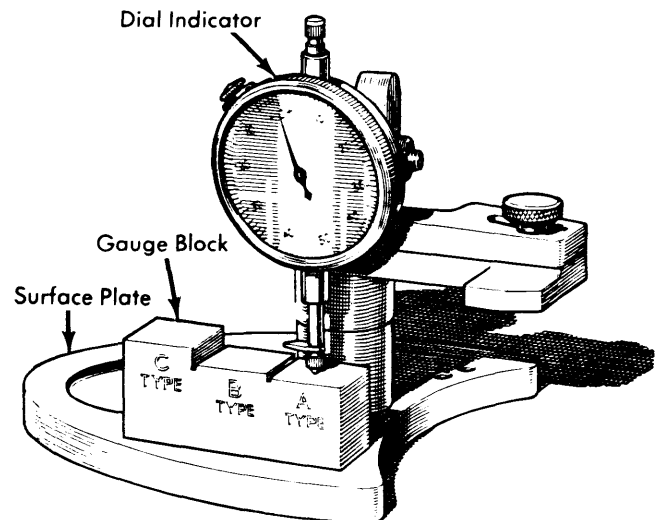
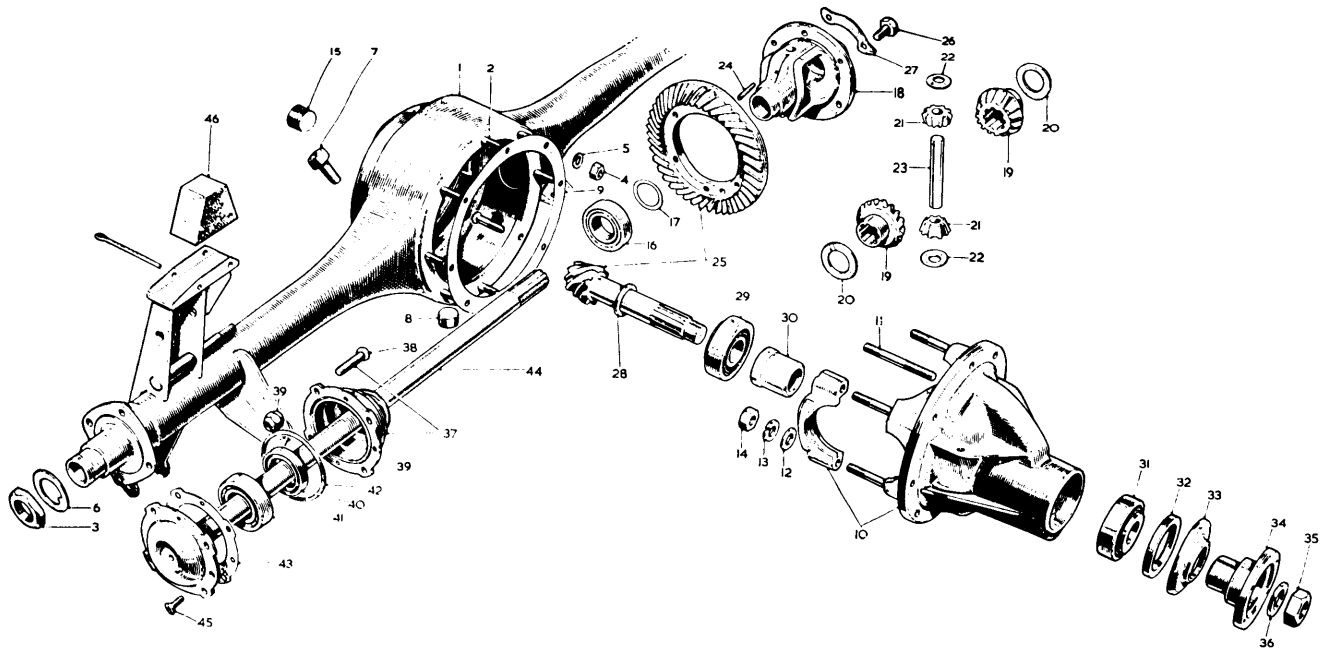

Fig. 1 Calibrating Dial Indicator Tool 18G-191

MG MIDGET (Cont.)



- 1 — Differential Housing
- 2 — Stud
- 3 — Hub Nut
- 4 — Nut
- 5 — Lock Washer
- 6 — Tabbed Washer
- 7 — Vent
- 8 — Drain Plug
- 9 — Gasket
- 10 — Carrier Assembly
- 11 — Bearing Cap Stud
- 12 — Washer
- 13 — Lock Washer
- 14 — Bearing Cap Nut
- 15 — Fill Plug
- 16 — Differential Bearings

- 17 — Shim
- 18 — Differential Cage
- 19 — Side Gear
- 20 — Thrust Washer
- 21 — Pinion Gear
- 22 — Thrust Washer
- 23 — Pinion Gear Shaft
- 24 — Locking Pin
- 25 — Ring & Drive Pinion Gears
- 26 — Ring Gear Bolt
- 27 — Lock Tab
- 28 — Thrust Washer
- 29 — Inner Drive Pinion Bearing
- 30 — Bearing Spacer
- 31 — Outer Drive Pinion Bearing
- 32 — Oil Seal

- 33 — Dust Cover
- 34 — Drive Pinion Flange
- 35 — Drive Pinion Nut
- 36 — Lock Washer
- 37 — Hub
- 38 — Lug Bolt
- 39 — Lug Nut
- 40 — Oil Seal
- 41 — Axle Shaft Bearing
- 42 — "O" Ring
- 43 — Gasket
- 44 — Axle Shaft
- 45 — Retaining Screw
- 46 — Rubber Bumper

Fig. 2 Exploded View of MG Midget Drive Axle Assembly

2) Install inner ring of front bearing and pinion flange and tighten nut slowly until a bearing preload of 8-10 INCH lbs. (9-12 kgcm) is obtained. Using tool 18G-191, adjust dial indicator to zero on machined step "A" of setting block (see illustration). Place dial indicator and base of tool on head of pinion and position tool so dial indicator feeler rests on center of differential bearing bore. Note any variation from zero. Now swing indicator to other bearing bore and again note variation from zero. Average the two variations together.

3) Take into consideration any variation in pinion head thickness. This will be shown as an unbracketed figure etched on pinion head and will always be minus. If no unbracketed

figure is shown, pinion head is of nominal thickness. Using the average dial indicator reading just obtained and the unbracketed figure from pinion head, perform the following calculation: If indicator reading is minus, add indicator reading to pinion head reading and REDUCE known washer thickness by this amount.

EXAMPLE:

Indicator Reading	-.002"
Pinion Marking	-.005"
Variation From Nominal	-.007"

Reduce known washer thickness by this amount.

MG MIDGET (Cont.)

4) If indicator reading is plus and numerically LESS than pinion marking, REDUCE the known washer thickness by the difference.

EXAMPLE:

Pinion Marking	-.005"
Indicator Reading	+.003"
Variation From Nominal	-.002"

Reduce known washer thickness by this amount.

5) If indicator reading is plus and numerically GREATER than pinion marking, INCREASE the known washer thickness by the difference.

EXAMPLE:

Indicator Reading	+.008"
Pinion Marking	-.003"
Variation From Nominal	+.005"

Increase known washer thickness by this amount.

6) The only cases where no changes are required to washer thickness are when indicator reading is PLUS and NUMERICALLY EQUAL to unbracketed pinion marking, or indicator reading is zero and there is no unbracketed marking on pinion head. Allowance should now be made as follows for mounting distance marked on pinion head in a rectangular bracket as follows:

7) If marking is a PLUS figure, REDUCE washer thickness by an equal amount. If marking is a MINUS figure, INCREASE washer thickness by an equal amount. A tolerance of .001" (.03 mm) is allowed in thickness of washer finally installed.

Pinion Bearing Preload — Install washer of thickness just calculated under pinion head and assemble pinion with bearings, pinion sleeve, oil seal, flange and nut. Pinion sleeve is of collapsible design and can only be used once. Therefore, the following procedure should be done with care or a new sleeve will be required. Slowly tighten flange nut to specifications while holding flange to prevent rotation. During tightening process, occasionally check pinion bearing preload. When nut is tightened to specifications, preload should be to specifications. Installation of pinion is now complete.

Side Bearing Preload — 1) The method of setting position of ring gear assembly depends on markings given on differential gear carrier and case. The dimensions to be considered are (see illustration): "A" — The dimension from center line to bearing on right side. Variation in dimension "A" is stamped on carrier adjacent to right side bearing bore. "B" — The dimension from center line to bearing on left side. Variation is stamped on left side bearing bore. "C" — Dimension from bearing on one side of cage to bearing on other side and "D" — Dimension from rear face of ring gear to bearing on opposite side. Variations on "C" & "D" dimensions are stamped on machined face of differential cage.

2) It is possible to calculate shim thickness required on left side by use of following formula:

$$A + D - C + .002"$$

Substituting the actual variations shown, this formula gives shim thickness required to compensate for variations in machining plus the extra .002" (.05 mm) to give necessary bearing preload. In addition, allowance must be made for variations in bearing thickness in the following manner:

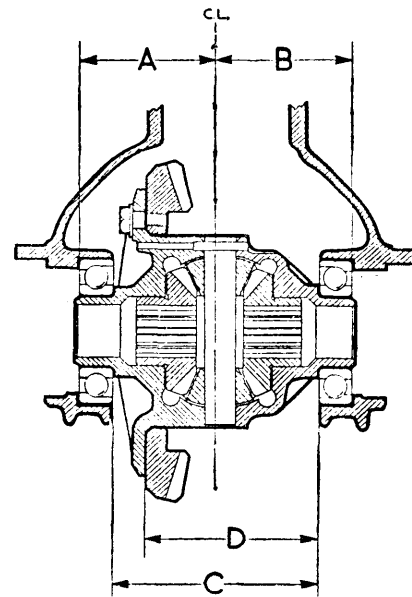

Fig. 3 Dimensions For Determining Side Bearing Preload

3) Rest bearing with inner race over recess and thrust face downwards on surface plate of tool 18G-191. Place dial indicator on surface plate and zero indicator on step "A" of gauge block of tool 18G-191. Swing indicator over until it rests on plain surface of inner bearing race. Hold inner race down against balls and note indicator reading. Indicator will normally indicate a negative reading. This negative variation should be ADDED to the shim pack previously calculated for that side of the differential.

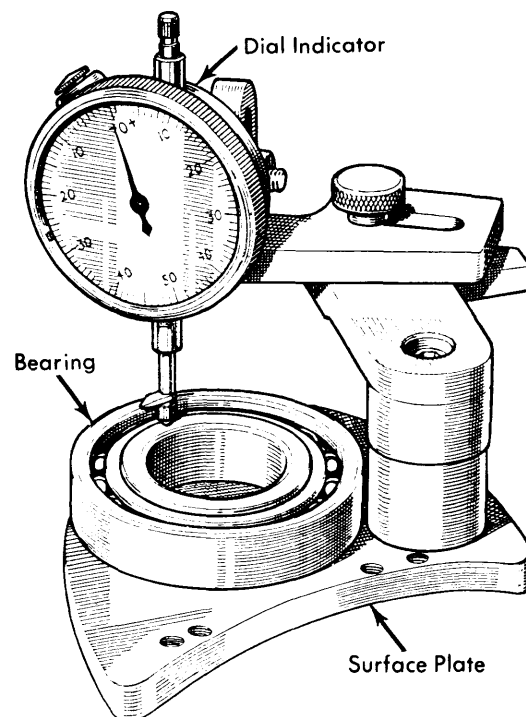

Fig. 4 Checking Bearing Thickness Variation Using Dial Indicator Tool 18G-191

MG MIDGET (Cont.)

4) To calculate the shim thickness for the right side, use the following formula:

$$B - D + .006",$$

substituting the actual values for "B" and "D" as described in 1). Again, final allowance must be made for variation in bearing thickness as described in 3) above.

5) When a framed number is marked on back of ring gear, e.g. +2, it must be taken into account before assembling shims and bearings to differential cage. If, for example, the mark is +2, then shims of .002" must be transferred from left (ring gear) side to right side. If marking is -2, shims of .002" must be moved from right to left side.

Backlash Adjustment - 1) Assemble bearings (thrust faces outwards) and shims as calculated to differential cage. Bolt ring gear to differential cage but do not knock over locking tabs. Mount assembly on two "V" blocks and check runout by means of dial indicator. If runout exceeds specifications, remove ring gear and check joint faces on cage ring gear for any particles of dirt. If parts are thoroughly cleaned it is unlikely that ring gear will not run true. Tighten bolts and knock over locking washers.

2) Install differential to carrier. Replace bearing caps and tighten nuts. Bolt surface plate of tool 18G-191 to carrier flange and mount dial indicator in such a way that an accurate backlash figure may be obtained. Correct figure for backlash to be used with any particular ring gear and pinion is etched on rear face of ring gear. A movement of .002" (.05 mm) shim thickness from one side of differential cage to the other will produce a variation in backlash of about .002" (.05 mm). Use care to ensure absolute cleanliness during this operation as dirt can result in inaccurate readings and poor settings. Carrier may now be installed in rear axle housing.

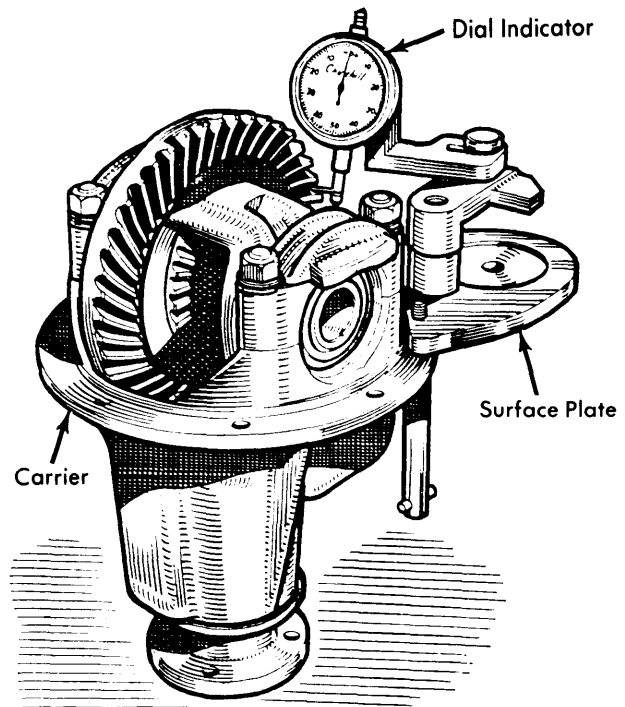

Fig. 5 Checking Ring Gear-to-Pinion Backlash Using Dial Indicator Tool 18G-191

AXLE ASSEMBLY SPECIFICATIONS

Pinion Bearing Preload 11-13 INCH Lbs. (12.6-14.9 kgcm)
 Ring Gear Runout002" (.05 mm)

TIGHTENING SPECIFICATIONS

Application	Ft. Lbs. (mkg)
Flange Nut Torque.....	135-140 (18.7-19.4)
Ring Gear Bolts.....	60 (8.3)
Differential Bearing Caps.....	65 (9)