

TOYOTA LAND CRUISER

FJ40 Series
FJ55 Series

DESCRIPTION

Clutch is dry, single plate, coil spring type. Clutch actuation is hydraulic, using a master cylinder mounted at pedal bracket on firewall and a slave cylinder attached to the engine mounting rear bracket. A prelubricated clutch release bearing is also used.

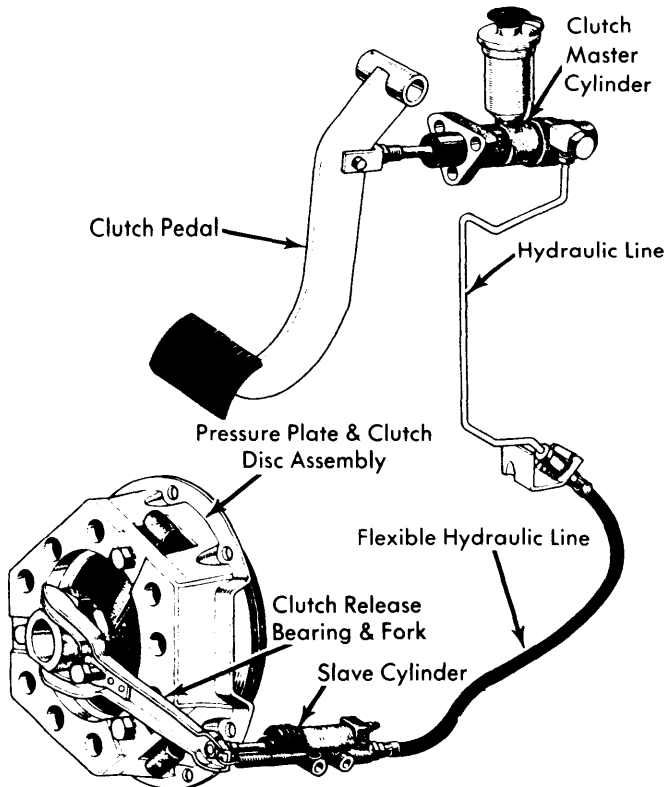

Fig. 1 View Showing Entire Clutch System

REMOVAL & INSTALLATION

CLUTCH ASSEMBLY

Removal – 1) Remove protective cover under transmission, and disconnect front and rear drive shafts from transfer case. Drain lubricant from transmission and transfer case. Disconnect parking brake cable from link lever. On FJ40 Series, drain fuel tank.

2) On FJ40 Series only, remove front seats, seat frames and console. Separate rear heater line clamp from tunnel. Remove fuel tank cover and fuel tank. On all series, remove shift lever boot and shift lever. Remove transmission cover.

3) Disconnect all electrical wires and vacuum lines from transfer case and transmission. Support transmission/transfer case assembly and remove mounting bolts.

4) Disconnect clutch fork return spring and remove slave cylinder, but do not disconnect hydraulic line unless necessary. Remove release bearing retaining clips, and release bearing with collar. Remove clutch lever assembly.

5) Mark pressure plate and flywheel for reassembly reference. Loosen clutch attaching bolts one turn at a time until spring pressure is released, then remove bolts and clutch assembly

Installation – To install, reverse removal procedure and note the following: Use suitable aligning tool to center disc on flywheel. Tighten clutch attaching bolts alternately and evenly. After reinstallation, adjust clutch fork free play and bleed hydraulic system if necessary.

CLUTCH MASTER CYLINDER

Removal – Remove clevis pin connecting master cylinder push rod to clutch pedal. Disconnect hydraulic line from cylinder body and plug opening. Remove cylinder attaching bolts at firewall and remove master cylinder. **CAUTION** – Do not allow fluid to spill on painted surfaces.

Installation – To install, reverse removal procedure, adjust pedal height and clutch pedal free play, and bleed hydraulic system. Check hydraulic system for leaks.

CLUTCH SLAVE CYLINDER

Removal – Plug master cylinder reservoir cap. Disconnect clutch return spring from hanger. Disconnect flexible hose from metal line and remove clip. Remove slave cylinder retaining bolts and remove slave cylinder.

Installation – To install, reverse removal procedure, adjust clutch fork free play and bleed hydraulic system.

CLUTCH RELEASE BEARING

NOTE – Procedure for removal and installation of clutch release bearing is identical to that of clutch assembly. See Clutch Assembly Removal & Installation.

PILOT BEARING

Removal & Installation – With clutch assembly removed, check pilot bearing in end of crankshaft for roughness or noise during rotation. If defective, remove using a suitable puller (0930355011). To install, lubricate bearing with multi-purpose grease and insert into crankshaft using suitable driver (0930447010).

OVERHAUL

CLUTCH MASTER CYLINDER

Disassembly – Remove reservoir cap, drain fluid, and remove float. Remove reservoir and rubber boot from cylinder body. Remove snap ring, push rod, piston stop plate and boot. Remove piston and return spring from cylinder, then remove cylinder cup from piston. Clamp cylinder cap in a vise and, using a pipe wrench on cylinder body, remove body from cap. Remove cylinder cup spacer from cylinder.

Clutches

TOYOTA LAND CRUISER (Cont.)

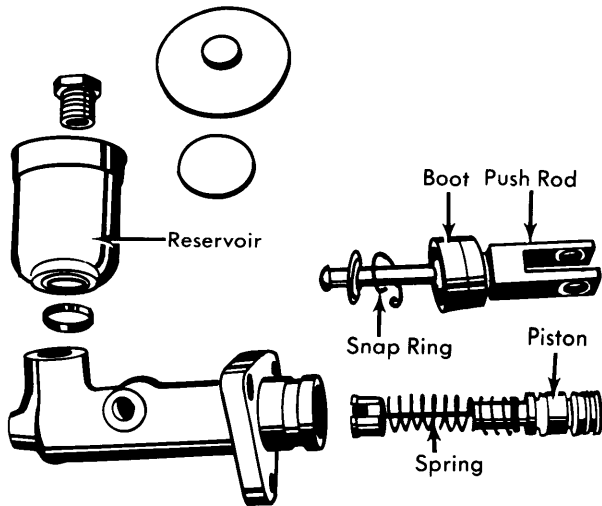

Fig. 2 Exploded View of Clutch Master Cylinder

Inspection — Clean all parts in clean brake fluid or alcohol and inspect for wear or damage. Check clearance between master cylinder bore and piston; if clearance exceeds .006", replace parts as necessary. Check return spring for wear or distortion. Replace spring if length is less than 3.31" with 4.5 lbs. load applied.

Reassembly — 1) *NOTE* — Manufacturer recommends replacing cylinder cups each time cylinder is disassembled. Soak all parts in clean brake fluid before assembly. Install piston stop plate, push rod, boot and snap ring into cylinder body.

2) Install a new cylinder cup onto piston, and insert piston into cylinder through front of bore. Install cup spacer and cylinder cup into cylinder bore. Install return spring with spring seat into cylinder and onto piston, then install cylinder cap with a new gasket.

3) Install reservoir onto master cylinder, install bolt and washer and tighten securely. Install float into fluid reservoir, and install reservoir cap.

CLUTCH SLAVE CYLINDER

Disassembly — Remove push rod assembly and rubber boot from cylinder body. Withdraw cylinder piston and cup seal. Loosen and remove bleeder screw.

Inspection — Clean all parts thoroughly and inspect for wear or damage. Check clearance between slave cylinder bore and piston; if clearance exceeds .006", replace parts as necessary. Inspect spring for wear or distortion, and check bleeder screw and its seat in cylinder body for damage or distortion.

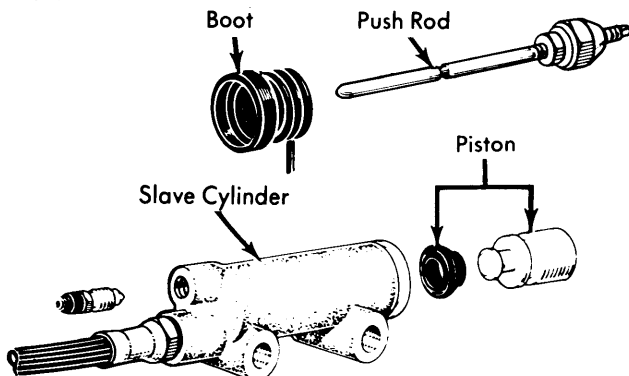

Fig. 3 Exploded View of Clutch Slave Cylinder

Reassembly — Soak all parts in clean brake fluid and reverse disassembly procedures. *NOTE* — Manufacturer recommends that cylinder cups be replaced whenever cylinder has been disassembled.

ADJUSTMENT

PEDAL HEIGHT

Pedal height is measured from floor mat to top of pedal pad (see illustration). Loosen lock nut and push rod. Adjust stop bolt until specified pedal height is obtained.

Pedal Height

Application

Height

FJ40 Series

With Power Brake Unit 8.27-9.06" (210-230 mm)

Without Power Brake Unit 7.28-7.87" (185-200 mm)

FJ55 Series

With Power Brake Unit 6.89-7.68" (175-195 mm)

Without Power Brake Unit 6.50-7.28" (165-185 mm)

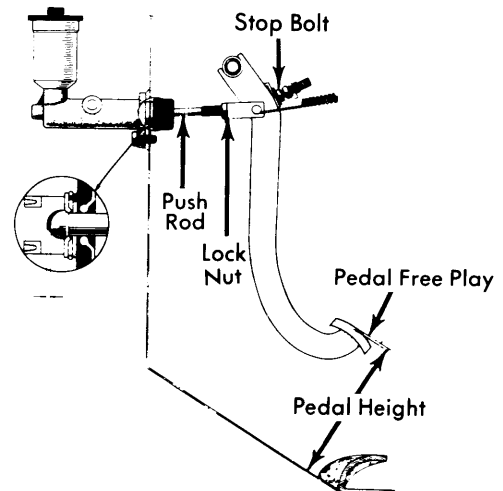

Fig. 4 View Showing Pedal Height Measuring & Adjusting Points

PEDAL FREE PLAY

Clutch pedal free play is measured from a point where pedal is in fully up position to a point where master cylinder push rod just contacts piston. Adjust free play by loosening lock nut and turning push rod to obtain specified pedal free play.

Pedal Free Play

Application

Free Play

All Models04-.27" (1-7 mm)

CLUTCH FORK FREE PLAY

To obtain correct amount of clearance between release bearing and pressure plate, adjust push rod tip to specifications.

Clutch Fork Free Play

Application

Free Play

All Models12-.16 (3-4 mm)

TOYOTA LAND CRUISER (Cont.)

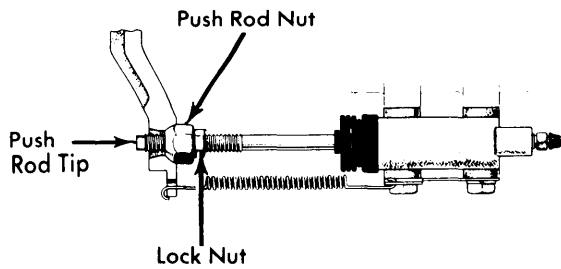

Fig. 5 View Showing Clutch Fork Adjustment Point

HYDRAULIC SYSTEM BLEEDING

1) Connect a flexible tube to slave cylinder bleeder screw, and place opposite end in a container partially filled with brake fluid.

2) Pump clutch pedal several times. With pedal depressed, loosen bleeder screw one-third to one-half turn and allow air to bleed out. Tighten bleeder screw.

3) Continue operation until air bubbles are no longer seen in fluid being discharged into container. Tighten bleeder screw securely and install cap. Check fluid level in master cylinder reservoir, and check system for leaks.

TIGHTENING SPECIFICATIONS

Application	Ft. Lbs. (mkg)
Engine-to-Clutch Housing.....	36-58 (5.0-8.0)
Pressure Plate-to-Flywheel.....	11-16 (1.5-2.2)
Reservoir.....	15-22 (2.0-3.0)