

## TOYOTA HI-LUX

## Hi-Lux Pickup

## DESCRIPTION

Clutch is dry, single plate, diaphragm spring type. Clutch actuation is hydraulic, using a firewall mounted master cylinder and a clutch housing mounted slave cylinder. A prelubricated clutch release bearing is also used.

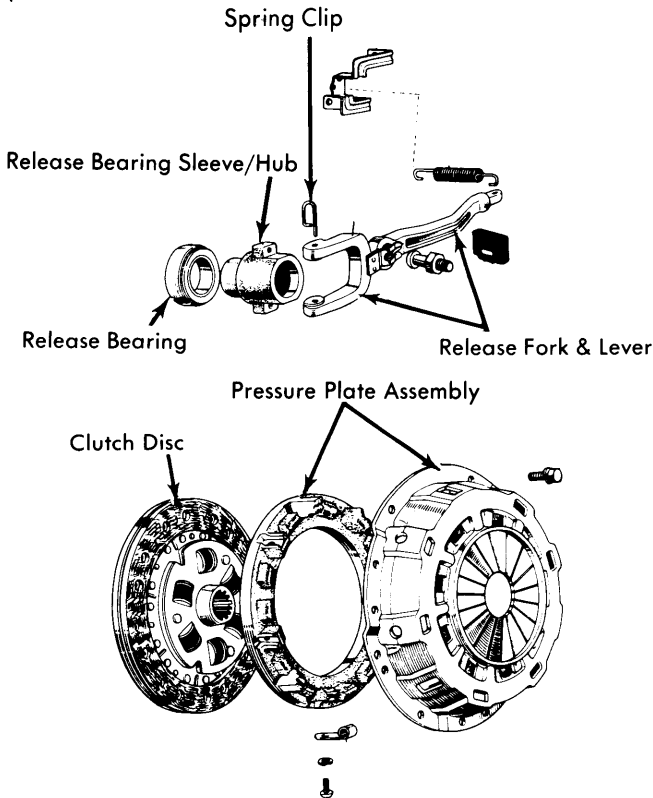

Fig. 1 Exploded View of Clutch Assembly

## REMOVAL &amp; INSTALLATION

## CLUTCH ASSEMBLY

**Removal** – 1) From inside vehicle, remove console, boot retainer, and shift lever boot. Remove shift lever using a suitable tool (09305-20011).

2) From engine compartment, disconnect positive battery cable and drain engine coolant, then disconnect upper radiator hose. Remove bolt attaching clutch flexible hose bracket to engine, then remove upper starter mounting nut. Disconnect accelerator torque rod.

3) Raise vehicle and support with safety stands. Remove lower starter mounting nut and remove starter. Disconnect slave cylinder from transmission. **NOTE** – Do not disconnect hydraulic line from slave cylinder unless necessary.

4) Disconnect exhaust pipe from manifold, and exhaust pipe clamp from clutch housing. Remove transmission mounting bolts and bracket. Remove parking brake intermediate lever. Disconnect speedometer cable and drive shaft. **NOTE** – Insert a plug into extension housing to prevent lubricant leakage.

5) Support transmission with a jack and remove rear transmission support crossmember. Insert a block of wood between engine oil pan and crossmember, lower jack, and remove clutch housing attaching bolts. Remove transmission.

6) Mark pressure plate and flywheel for reassembly reference. Loosen pressure plate attaching bolts one turn at a time until spring pressure is released, then remove bolts and clutch assembly.

**Installation** – To install, reverse removal procedure and note the following: Use a suitable aligning tool to center clutch disc on flywheel. Align marks made during removal and tighten attaching bolts alternately and evenly.

## CLUTCH MASTER CYLINDER

**Removal** – Disconnect hydraulic line from master cylinder. Disconnect push rod from clutch pedal. Remove attaching nuts and remove master cylinder from firewall. **CAUTION** – Do not allow hydraulic fluid to spill on painted surfaces.

**Installation** – Install master cylinder on firewall. **NOTE** – Before tightening attaching nuts, install but do not tighten hydraulic line. Install push rod to clutch pedal and attach return spring. Tighten hydraulic line. Adjust pedal height and master cylinder push rod free play, and bleed hydraulic system.

## CLUTCH SLAVE CYLINDER

**Removal** – Raise front of vehicle and support with safety stands. Remove clutch fork return spring and hydraulic line. Loosen lock nut and slave cylinder push rod, then remove attaching nuts and slave cylinder.

**Installation** – To install, reverse removal procedure and note the following: After installation, adjust clutch fork free play and bleed hydraulic system.

## CLUTCH RELEASE BEARING

**Removal & Installation** – With transmission assembly removed, remove spring clips and slide release bearing off transmission input shaft. To install, apply grease to transmission front bearing retainer and bearing contact surface of clutch fork, then install bearing and spring clips.

## PILOT BEARING

**Removal & Installation** – Check bearing in end of crankshaft for roughness or noise during rotation. **NOTE** – Do not remove bearing unless defective. Remove bearing using a suitable puller (09303-35010). Apply multi-purpose grease to new bearing and install into crankshaft using a suitable driver (09304-30012).

## OVERHAUL

## CLUTCH MASTER CYLINDER

**Disassembly** – Remove master cylinder cap, float, reservoir retaining bolt, and reservoir. Pull back rubber boot and remove snap ring, push rod, and all internal components. Clean all parts in clean brake fluid.

## TOYOTA HI-LUX (Cont.)

**Inspection** — Check all parts for wear or damage. Check clearance between master cylinder bore and piston; if clearance exceeds .006" (.15 mm), replace parts as necessary. Check compression spring for distortion.

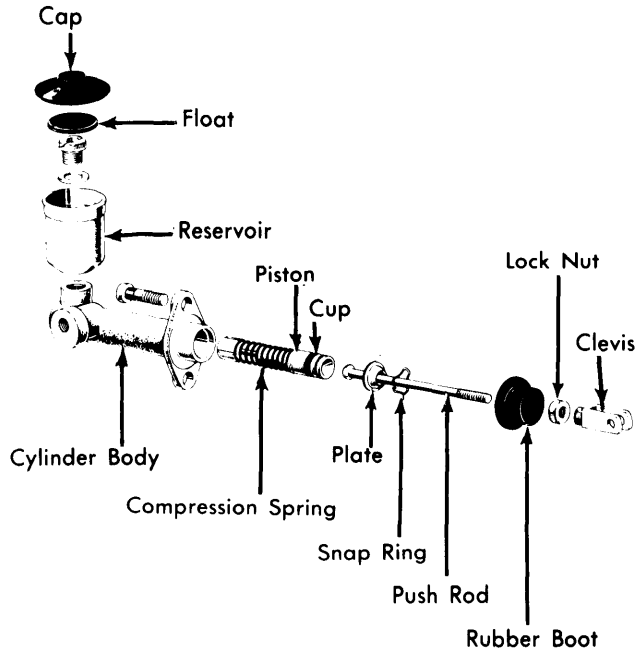

Fig. 2 Exploded View of Clutch Master Cylinder

**Reassembly** — *NOTE* — Manufacturer recommends replacing all rubber parts whenever master cylinder has been disassembled. Soak all parts in clean brake fluid, then install piston, push rod, and plate in cylinder and secure with snap ring. Install rubber boot and fluid reservoir.

### SLAVE CYLINDER

**Disassembly** — Remove push rod and boot from slave cylinder. Remove release piston with cup attached. *NOTE* — Do not remove cup from piston unless replacement is required.

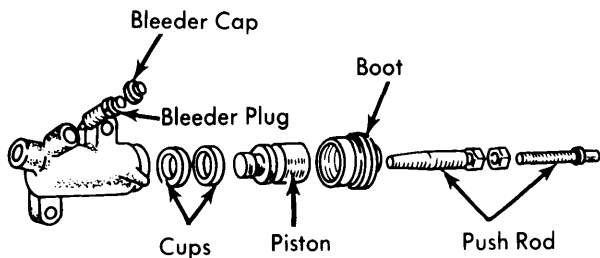

Fig. 3 Exploded View of Clutch Slave Cylinder

**Inspection** — Clean all parts and inspect for wear or damage. Check clearance between slave cylinder bore and piston; if clearance exceeds .006" (.15 mm), replace parts as necessary.

**Reassembly** — Coat all parts with clean brake fluid before assembly. Install cylinder cups on piston, then install piston into cylinder bore. Install rubber boot and push rod assembly.

## ADJUSTMENT

### PEDAL HEIGHT

Pedal height is measured from floor mat to top of pedal pad. Adjust pedal stop bolt at top of pedal assembly until pedal height is 6.3" (160 mm).

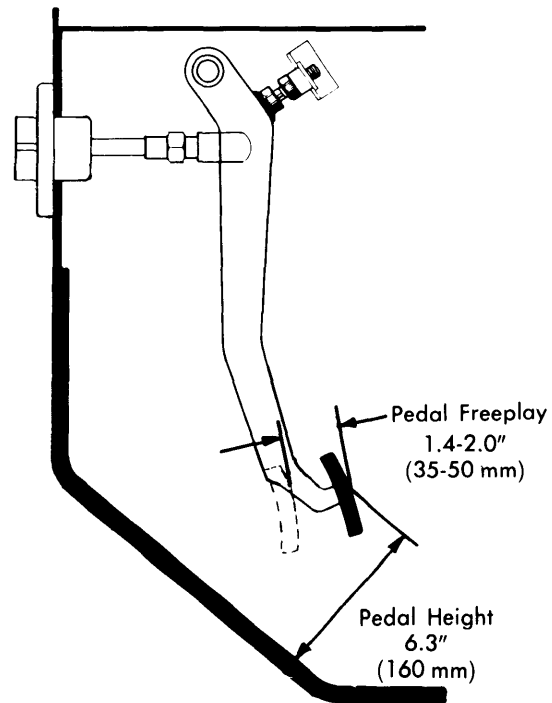

Fig. 4 View Showing Pedal Height & Freeplay Measuring Points

### CLUTCH PEDAL FREE PLAY

Clutch pedal free play is a combination of the following points: Play between master cylinder push rod and piston, play until cylinder cup closes piston port, and play at release fork tip. If all prior adjustments have been carried out properly, clutch pedal free play should be 1.4-2.0" (35-50 mm), measured at pedal.

### MASTER CYLINDER PUSH ROD FREE PLAY

Adjust play between master cylinder push rod and piston by loosening lock nut and turning push rod until a clearance of .02-.12" (.5-3.0 mm) is obtained at top of pedal.

# Clutches

## TOYOTA HI-LUX (Cont.)

### CLUTCH FORK FREE PLAY

Adjust play at clutch fork by loosening lock nut and turning outer half of push rod until a clearance of .08-.14" (2.0-3.5 mm) is obtained, measured at outer tip of clutch fork.

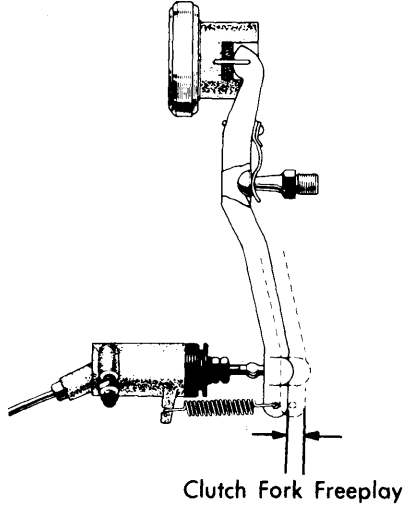

Fig. 5 View Showing Clutch Fork Freeplay Measuring Point

### HYDRAULIC SYSTEM BLEEDING

- 1) Ensure master cylinder reservoir is full. Raise rear of vehicle and support with safety stands. Remove bleeder screw cap on slave cylinder and attach a flexible hose. Insert opposite end of hose into a container partially filled with brake fluid.
- 2) Pump clutch pedal several times, and when fully depressed, open slave cylinder bleeder screw one-third to one-half turn. Continue operation until air bubbles are no longer seen in discharged fluid. Tighten bleeder screw and install cap. Fill master cylinder reservoir and check system for leaks.

### TIGHTENING SPECIFICATIONS

Application	Ft. Lbs. (mkg)
Master Cylinder Reservoir Set Screw.....	14-20 (2.0-3.0)
Clutch Housing-to-Flywheel.....	36-50 (5.0-7.0)
Pressure Plate-to-Flywheel.....	11-16 (1.5-2.2)