

TOYOTA PASSENGER

Celica
Corolla 1600
Corona
Corona MK II

DESCRIPTION

Clutch is a dry, single plate, diaphragm spring type. Clutch actuation is hydraulic, using a firewall mounted master cylinder and a clutch housing mounted slave cylinder. A pre-lubricated clutch release bearing is also used.

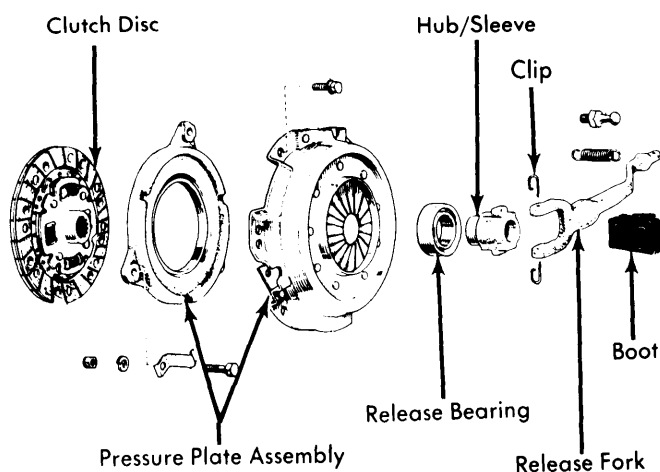

Fig. 1 Exploded View of Clutch Components

REMOVAL & INSTALLATION

CLUTCH ASSEMBLY

Removal — 1) Disconnect battery cable. Remove air cleaner and drain cooling system, then disconnect top radiator hose. Disconnect accelerator control rod linkage. Remove shift lever boot and shifter assembly. Remove starter.

2) Raise vehicle and support at front and rear with jack stands. If equipped, remove protective cover from under engine.

3) Remove clutch slave cylinder, but only disconnect hydraulic line if necessary. Disconnect exhaust pipe support bracket from mounting and separate exhaust pipe from manifold. Disconnect speedometer cable and electrical leads from transmission.

4) Scribe index marks on drive shaft and coupling for reinstallation reference, then remove drive shaft. Insert suitable plug into extension housing to prevent oil spillage.

5) Support transmission using a floor jack and remove rear support crossmember. Lower jack and remove bolts mounting transmission to engine. Index mark clutch assembly and flywheel for reassembly. Loosen bolts securing clutch assembly alternately and evenly until pressure is released from clutch. Lift out clutch assembly.

Installation — To install, reverse removal procedure and note the following: Use a suitable aligning tool to center clutch disc on flywheel. Tighten clutch pressure plate attaching bolts alternately and evenly in a diagonal progression. With transmission installed, adjust clutch.

CLUTCH MASTER CYLINDER

Removal — Remove cotter pin and clevis pin connecting master cylinder push rod to clutch pedal, then disconnect push rod. Disconnect hydraulic line from cylinder, remove cylinder attaching nuts at firewall, and remove cylinder from vehicle.

Installation — To install, reverse removal procedure and note the following: When installing master cylinder, make sure rubber boot hole faces downward. Adjust pedal height and free play, and bleed hydraulic system.

CLUTCH SLAVE CYLINDER

Removal — Raise front of vehicle and support with safety stands. If equipped, remove protective cover under engine. Remove return spring and disconnect hydraulic line. Back off push rod and remove slave cylinder attaching nuts and slave cylinder.

Installation — To install, reverse removal procedure and note the following: After installing slave cylinder, adjust free play at release lever and bleed hydraulic system.

CLUTCH RELEASE BEARING

Removal — With transmission removed, check release bearing for freedom of rotation with bearing still installed on hub. To remove, disconnect spring clips from bearing collar and slide bearing off transmission input shaft. Use a press to remove and install bearing on collar.

Installation — Slide bearing and collar over transmission input shaft and secure to release lever with new retaining clips. Apply grease to diaphragm spring contact points before installing transmission.

PILOT BEARING

Removal — With transmission and clutch assembly removed, check pilot bearing in crankshaft for roughness or noise. If required, remove bearing using a suitable puller (09303-35010).

Installation — Apply grease to new bearing and install into crankshaft using a suitable driver (09304-30012 for Corona models, or 09304-12011 for all others).

OVERHAUL

CLUTCH MASTER CYLINDER

Disassembly, Corona Mk II — With cylinder removed from vehicle, mount unit in a vise, taking care not to damage reservoir mounting surface. Remove bolt retaining reservoir to cylinder body, and separate reservoir from body. Remove cylinder end cap and snap ring and remove all internal parts.

TOYOTA PASSENGER (Cont.)

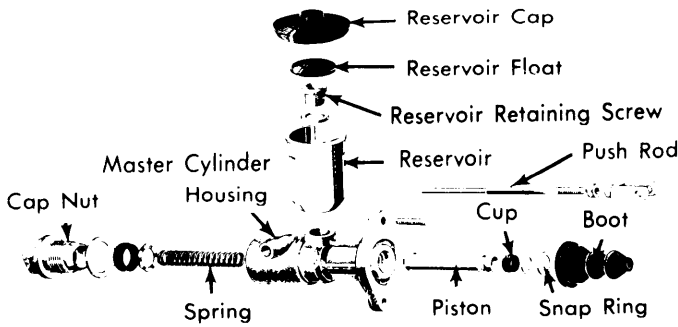

Fig. 2 Exploded View of Corona Mk II Clutch Master Cylinder

Inspection, Corona Mk II — Inspect cylinder and piston for wear or scores, replace as necessary. Check spring for weakening and reservoir for damage. Ensure vent hole in reservoir cap is clear. Check piston cup spacer for wear, damage or distortion. **NOTE** — Manufacturer recommends replacing seals whenever cylinder has been disassembled.

Reassembly, Corona Mk II — 1) Dip cylinder cups in clean brake fluid or coat with rubber grease before assembly. Install push rod in cylinder body and secure with snap ring, then install rubber boot.

2) Install cylinder cup on piston and insert in cylinder from front end. Install spacer and cup. Install spring seat on spring, install into cylinder, then install and tighten end cap. Position reservoir on cylinder, and install and tighten bolt.

Disassembly, All Others — With cylinder removed from vehicle, clamp it into a soft jawed vise. Remove reservoir, snap ring, and push rod. Pull out piston, cup, and remaining internal components. Further disassemble piston by prying up spring retainer and separating retainer from piston.

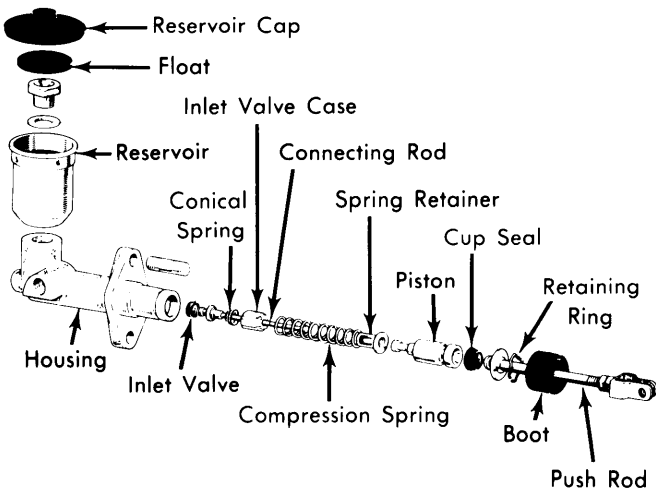

Fig. 3 Exploded View of Clutch Master Cylinder (Corona, Celica, Corolla Shown)

Inspection, All Others — Clean all parts in clean brake fluid. Check master cylinder piston to bore for a clearance of .006" (.15 mm); replace components as necessary. Check compression spring for distortion or weakening, and reservoir for damage. Make sure vent hole in reservoir cap is open.

Reassembly, All Others — Dip cylinder cups into clean brake fluid or coat with rubber grease before assembly. Assemble piston components in reverse order of disassembly. Install piston assembly, push rod, and reservoir into master cylinder.

CLUTCH SLAVE CYLINDER

Disassembly — With slave cylinder removed from vehicle, remove rubber boot and push rod. Remove piston and cups, then remove bleeder screw.

Inspection — Thoroughly clean all parts with clean brake fluid and inspect for wear or damage. **NOTE** — Manufacturer recommends replacing seals each time slave cylinder is disassembled.

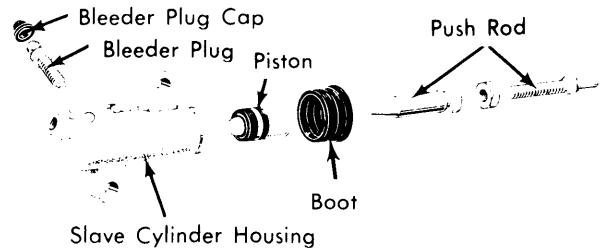

Fig. 4 View of Typical Slave Cylinder — Corona Mk II Shown

Reassembly — Soak all parts in clean brake fluid before assembly. Install seals on piston, then install piston into cylinder. Install rubber boot and push rod. Install bleeder screw and cap.

ADJUSTMENT

PEDAL HEIGHT

Adjust pedal stop bolt at top of pedal assembly until specified pedal height is obtained. Height is measured from floor mat to top of pedal pad.

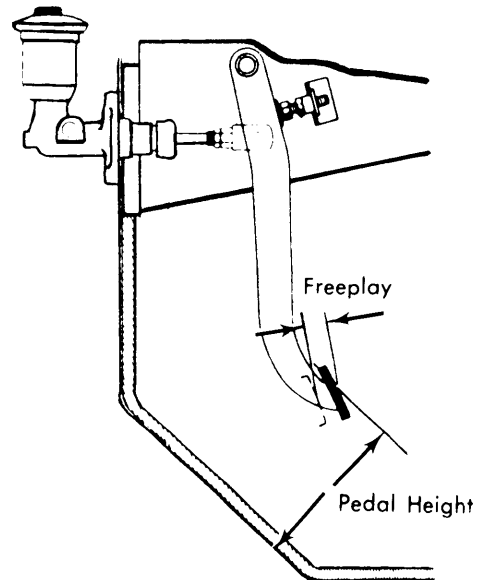

Fig. 5 Pedal Height and Free Play Measuring Points

TOYOTA PASSENGER (Cont.)

Pedal Height Specifications

Application	Height
Celica	6.3" (160 mm)
Corolla 1600.....	6.4" (164 mm)
Corona	6.3-6.8" (160-170 mm)
Corona Mk II	6.2-6.6" (153-163 mm)

Clutch Fork Free Play Specifications

Application	Free Play
Celica079-.138" (2.0-3.5 mm)
Corolla 16001-.138" (2.5-3.5 mm)
Corona079-.118" (2.0-3.0 mm)
Corona Mk II079-.138" (2.0-3.5 mm)

MASTER CYLINDER PUSH ROD FREE PLAY

To obtain specified free play between pedal push rod and master cylinder piston, loosen lock nut on push rod and adjust rod until specified free play is obtained.

Master Cylinder Push Rod Free Play Specifications

Application	Free Play
Celica.....	.04-.12" (1.0-3.0 mm)
Corona.....	.04-.28" (1.0-7.0 mm)
Corona Mk II.....	.04-.24" (1.0-6.0 mm)

PEDAL FREE PLAY

Pedal free play is total of clutch fork free play and master cylinder push rod free play, and is measured at pedal pad. If other measurements are to specification, pedal free play should be as specified in table.

Pedal Free Play Specifications

Application	Free Play
Celica, Corona, Corolla 1600	1.0-1.75" (25-45 mm)
Corona Mk II	1.4-2.0" (35-50 mm)

HYDRAULIC SYSTEM BLEEDING

- 1) Raise vehicle and support with safety stands. Make sure clutch master cylinder reservoir is full of fluid. Remove bleeder screw cap and loosen bleeder screw. Place a finger on vent hole of bleeder screw and push clutch pedal to bottom of stroke three or four times.
- 2) With pedal fully depressed, remove finger and allow air to vent out. Repeat procedure three or four times or until pressure is felt. Install a flexible hose on bleeder screw and insert free end into a container partially full of brake fluid.
- 3) Push pedal to bottom of stroke, loosen bleeder screw, and allow fluid to bleed into container. Tighten bleeder screw and release clutch pedal. Repeat procedure until air bubbles are no longer seen in container, then close screw on a down stroke of pedal. Check system for leaks and fill master cylinder.

CLUTCH FORK FREE PLAY

Clutch fork free play determines amount of clearance between clutch release bearing and clutch. To obtain specified free play, loosen lock nut on slave cylinder push rod and screw push rod in or out until specified free play is obtained.

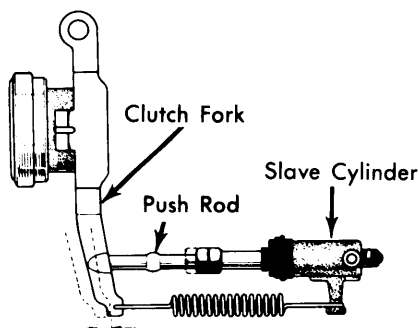

Fig. 6 Clutch Fork Free Play Measurement Location

TIGHTENING SPECIFICATIONS

Application	Ft. Lbs. (mkg)
Clutch Cover-to-Flywheel	11-16 (1.5-2.2)
Clutch Housing-to-Engine Mk II, Corolla 1600.....	36-50 (5.0-7.0)
Corona, Celica	36-58 (5.0-8.0)
Master Cylinder Set Bolt	14-22 (2.0-3.0)