

MG MIDGET

Midget

DESCRIPTION

The clutch is a single, dry-disc type, using a diaphragm spring type pressure plate. Clutch actuation is hydraulic. Hydraulic components are a firewall-mounted master cylinder and a clutch housing-mounted slave cylinder. The hydraulic design of the clutch control eliminates the necessity of pedal adjustment.

REMOVAL & INSTALLATION

CLUTCH ASSEMBLY

Remove engine. See *Engine Removal* in *ENGINE* Section. If engine and transmission are removed as an assembly, disconnect and remove transmission. Mark all parts for reassembly reference, then loosen clutch attaching bolts one turn at a time until pressure plate spring tension is released. Remove bolts and clutch assembly. To install, use a suitable aligning tool to center disc on flywheel, and reverse removal procedure.

CLUTCH MASTER CYLINDER

Removal – Remove the high tension lead from ignition coil and white/blue lead from ballast resistor. Remove the four screws mounting cover plate and remove with ignition coil. Remove cotter pin and separate clevis pin. Disconnect and plug hydraulic line at master cylinder. Remove bolts mounting master cylinder and lift from pedal box.

Installation – To install master cylinder, reverse removal procedure and note the following: Bleed clutch hydraulic system.

CLUTCH SLAVE CYLINDER

Removal – Disconnect hydraulic line from slave cylinder and plug open line. Remove mounting hardware and withdraw slave cylinder from housing.

Installation – Center push rod in cylinder housing. Align groove in slave cylinder with bolt hole in housing. Attach mounting hardware, reconnect hydraulic line and bleed slave cylinder.

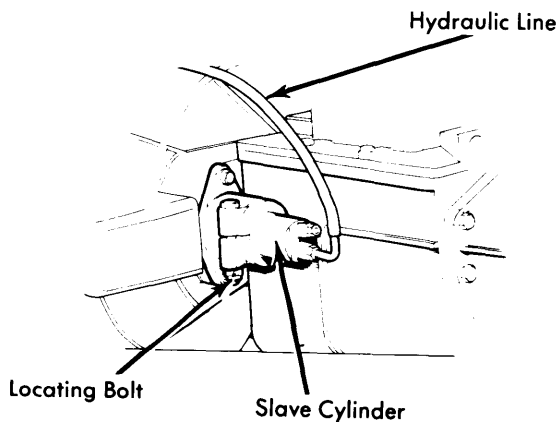

Fig. 1 Installed View of Clutch Slave Cylinder

CLUTCH RELEASE LEVER & RELEASE BEARING

Removal – With transmission and clutch housing removed, drive out pin retaining clutch release bearing lever in clutch housing. Press out pins from release lever. Remove both bearing sleeve plugs and separate bearing from release lever. Sleeve can now be pressed from bearing.

Installation – Grease sleeve and bearing, then press bearing onto sleeve. Fit bearing in release lever and insert sleeve locating plugs. Press in both pins to retain plugs. Reinstall release lever.

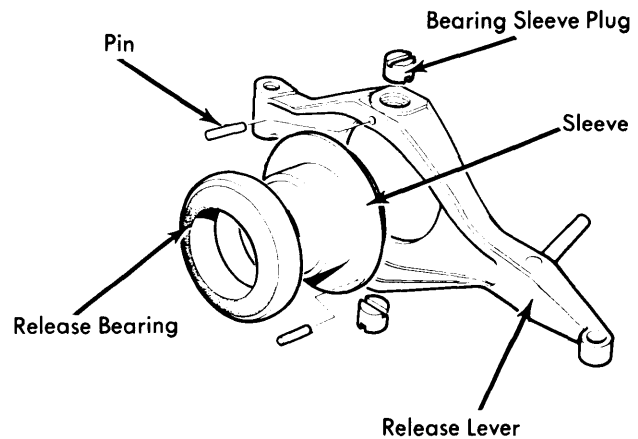

Fig. 2 Exploded View of Clutch Release Bearing & Lever

OVERHAUL

CLUTCH MASTER CYLINDER

Disassembly – Drain fluid from reservoir. Separate rubber boot from housing and slide off push rod. Disengage snap ring holding push rod, then pull out push rod with snap ring, dished washer, and rubber boot. Extract piston with second-

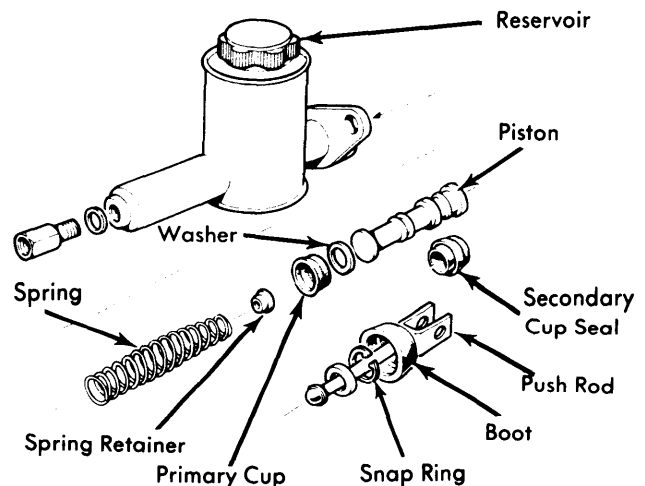

Fig. 3 Exploded View of Clutch Master Cylinder

MG MIDGET (Cont.)

dary cup seal. Remove piston washer, primary cup seal spring retainer, and spring. Separate secondary cup seal from piston; it must be stretched over end of piston.

Inspection — Wash master cylinder in suitable cleaner and clean internal components with brake fluid. Check cylinder bore for ridges or score marks. New seals can be used if cylinder is not damaged.

Reassembly — Fit new secondary cup seal over piston with lip of seal facing piston head. Insert spring retainer into small end of spring and fit spring into body, large end first. Install the following: primary cup seal, washer, piston, and push rod. **NOTE** — When fitting cup seals, install lip edge of cup seals into bore first. Engage snap ring and pull over boot.

CLUTCH SLAVE CYLINDER

Disassembly — Remove bleed valve, dust boot, plunger (piston), spring, then separate seal from plunger.

Inspection — Wash slave cylinder body in suitable cleaner and clean all internal components in brake fluid. Install new seals if cylinder bore is not damaged. Replace cylinder if bore is excessively damaged.

Reassembly — Fit seal to plunger. Refit spring and plunger into cylinder bore. Install bleed valve. Slip dust boot into position, install slave cylinder, and bleed hydraulic system.

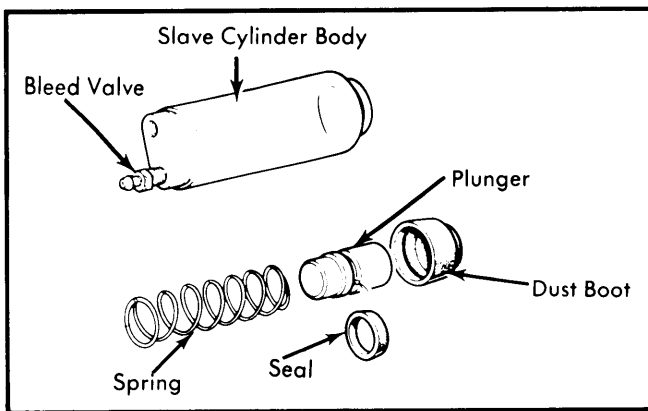

Fig. 4 Exploded View of Clutch Slave Cylinder

ADJUSTMENT

CLUTCH PEDAL FREE PLAY

Free play is preset at factory and should not need adjustment. However, if adjustment has been disturbed, adjust master cylinder push rod until pedal can be depressed approximately $\frac{5}{32}$ " before piston begins to move. When adjustment is correct, distance between master cylinder push rod and piston will be $\frac{1}{32}$ ".

HYDRAULIC SYSTEM BLEEDING

Fill master cylinder and attach a bleed hose to slave cylinder bleed valve; submerge free end of hose in a half-full container of brake fluid. Pump clutch pedal, open bleed valve approximately three-quarters turn; at end of down stroke close bleed valve. Continue procedure until air bubbles stop.