

Volvo Engines

240 SERIES 4 CYLINDER

GENERAL SPECIFICATIONS										
Year	Displ.		Carburetor	HP at RPM	Torque (Ft. Lbs. at RPM)	Compr. Ratio	Bore		Stroke	
	cu. ins.	cc					in.	mm	in.	mm
1975 B 20 F Federal Calif.	121.43	1990	F.I.	98@6000	110@3500	8.7-1	3.50	88.9	3.15	80
	121.43	1990	F.I.	94@6000	105@3500	8.7-1	3.50	88.9	3.15	80

ENGINE IDENTIFICATION

Engine type designation, part number, and manufacturing serial number are located on machined surface on left forward side of cylinder block. Code for engine will be B 20 F.

ENGINE REMOVAL

1) Remove gearshift lever, detach hood, and disconnect battery. Drain cooling system at radiator and cylinder block. Remove lower radiator hose from engine. Disconnect PCV hose, and brake assist hoses at intake manifold and vacuum pump. Disconnect coil wires and distributor wires. Disconnect wires and cable to starter, then disconnect ground cable from cylinder block.

2) Disconnect air bellows from CI unit to intake manifold. Disconnect the following fuel lines: control pressure regulator (one hose), cold start injector (one hose), distributor pipe to engine (two hoses), front fuel filter to engine (two hoses), and injector hoses (four hoses). Disconnect fuel filter from firewall and position to one side.

3) Disconnect wires at the following components: control pressure regulator, cold start injector, auxiliary air valve, thermal time switch, oil pressure switch, and temperature sender. Disconnect diverter valve hoses at firewall. Remove air injection reactor pipe. Disconnect charcoal canister vacuum hoses at intake manifold.

4) Disconnect throttle cable from housing and intake manifold bracket. Disconnect alternator wiring connector, then remove EGR valve from intake manifold. Remove thermal time switch with extension. Disconnect oil cooler lines at radiator (automatic transmission only). Disconnect expansion tank hose at radiator, then remove fan shroud attaching screws and position shroud to rear.

5) Disconnect upper radiator hose at engine and remove radiator with fan shroud. Disconnect water hoses at firewall, then remove windshield washer reservoir. Remove power steering pump drive belt and pulley, remove pump from bracket and position to one side. Remove idler roller for air pump drive belt. Disconnect transmission fill pipe from flywheel housing (automatic transmission only).

6) Install front and rear lifting lugs to cylinder block (SVO 2869 & 2870). Raise vehicle and support with stands. Disconnect exhaust pipe from manifold. Remove EGR valve and pipe. Remove front and rear engine mount attaching nuts. Use a hoist to raise engine slightly so rear engine mount is free.

7) Disconnect transmission ground cable. Disconnect clutch linkage (manual transmission) and gearshift control

(automatic transmission) from transmission. Remove front exhaust pipe clamp and transmission crossmember support. Disconnect speedometer cable and all electrical leads from transmission. Disconnect propeller shaft from transmission flange.

8) Lower rear of engine. Remove front heat shield, and oil lines between transmission and engine on models with automatic transmission. Raise engine using hoist while lowering rear of engine. Pull engine forward over front axle, then remove engine and transmission as an assembly.

INTAKE & EXHAUST MANIFOLDS

Removal – 1) Disconnect battery ground cable, then remove air bellows from CI unit to intake manifold. Disconnect PCV hoses at intake manifold and flame arrester. Disconnect vacuum pump hose at intake manifold. Disconnect diverter valve hoses. Disconnect air pump with tensioner and position to one side.

2) Disconnect the following fuel lines: control pressure regulator (one hose), cold start injector (one hose), distributor pipe to engine (two hoses) front fuel filter to engine (two hoses), and injector hoses (four hoses). Disconnect wiring at control pressure regulator, cold start injector, and auxiliary air valve.

3) Remove air injection pipe. Disconnect throttle cable from intake manifold. Disconnect charcoal canister hoses and EGR valve hose from intake manifold. Remove intake manifold brace, attaching nuts, and intake manifold. Disconnect transmission fill pipe from flywheel housing (automatic transmissions only). Remove attaching nuts and exhaust manifold.

Installation – To install, reverse removal procedure and use new manifold gaskets. Tighten nuts and bolts to specifications.

CYLINDER HEAD

Removal – 1) Drain cooling system at radiator and cylinder block. Disconnect battery ground cable. Disconnect upper radiator hose at engine. Disconnect air bellows between CI unit and air cleaner. Remove PCV hoses from intake manifold and oil trap on block. Disconnect vacuum pump hose at intake manifold.

2) Disconnect diverter valve hoses. Remove air pump and bracket. Disconnect the following fuel lines: control pressure regulator (one hose), cold start injector (one hose), distributor pipe to engine (two hoses), front fuel filter to engine (two hoses), and injector hoses (four hoses).

240 SERIES 4 CYLINDER (Cont.)

3) Disconnect wires at following components: control pressure regulator, cold start injector, auxiliary air valve, and temperature sender. Disconnect throttle cable from intake manifold. Disconnect charcoal canister hoses and EGR valve hose from intake manifold. Disconnect transmission fill pipe from transmission housing (automatic transmissions only).

4) Remove water pipe rear clamp from manifold. Remove exhaust manifold to exhaust pipe attaching nuts. Remove intake manifold brace. Disconnect spark plug cables at plugs, then disconnect upper water hose at firewall. Remove valve cover, rocker arm shaft and push rods. Remove cylinder head bolts and lift cylinder head from engine.

Installation - 1) To install cylinder head, use guide pins (SVO 2435) inserted in front right hole and left rear hole. Ensure new head gasket is installed with "TOP" mark upward. When head is positioned, remove guide pins, then install and tighten cylinder head bolts in three steps as indicated in table and according to illustrated sequence.

2) Install push rods and rocker arm shaft. Adjust valves to .018-.020" (.45-.50 mm). See *Valve Clearance Adjustment for procedure*. Reverse remainder of removal procedure, then

make final valve adjustment (after running engine for ten minutes) to .016-.018" (.40-.45 mm). Retorque cylinder head bolts.

Cylinder Head Tightening Specifications

Sequence	Ft. Lbs. (mkg)
Step One	30(4.0)
Step Two	60(8.3)
Step Three	①65(9.0)

① - After running engine for ten minutes.

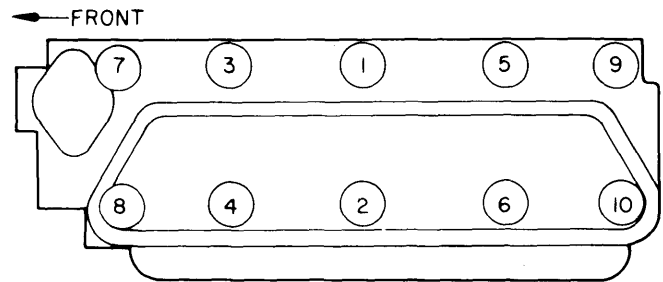

Fig. 1 Cylinder Head Tightening Sequence

VALVES							
Engine & Valve	Head Diam. In. (mm)	Face Angle	Seat Angle	Seat Width In. (mm)	Stem Diameter In. (mm)	Stem Clearance In. (mm)	Valve Lift In. (mm)
B 20 F Intake	1.732 (44)	45°	44.5°	.08 (2)	.3132-.3138 (7.96-7.97)	.0012-.0026 (.030-.068)	.28 (7.2)
Exhaust	1.378 (35)	45°	44.5°	.08 (2)	.3120-.3126 (7.93-7.94)	.0024-.0038 (.060-.097)	.28 (7.2)

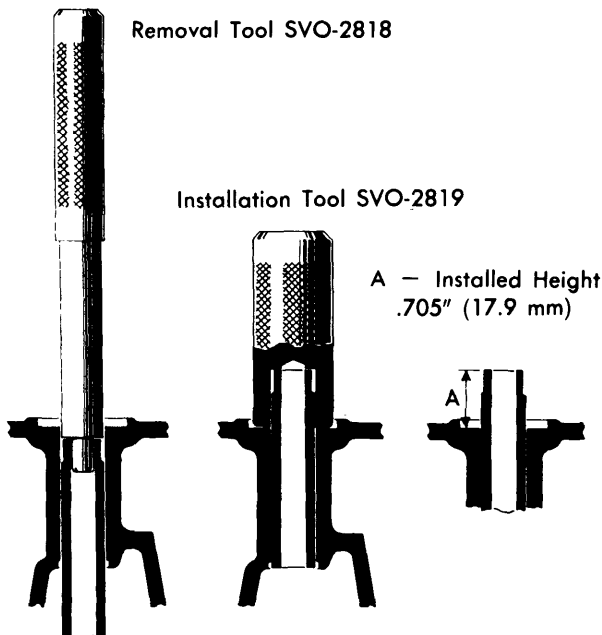

Fig. 2 Valve Guide Removal, Installation & Height

VALVE ARRANGEMENT

E-I-I-E-E-I-I-E - Front to rear.

VALVE GUIDE SERVICING

Removal & Installation - Press out old guides using suitable tool (SVO-2818 or equivalent). Press in new guides using drift tool (SVO-2819) to gain correct depth. B-20-F engine uses a .016" (.4 mm) washer between drift tool and cylinder head surface. Check to see that guides are free from burrs, and that valves move freely in guides.

VALVE SPRINGS			
Engine	Free Length In. (mm)	PRESSURE Lbs. @ In. (kg @ mm)	
		Valve Closed	Valve Open
B 20 F	1.81 (46)	60-70@1.57 (26-32@40)	172-191@1.18 (77-87@30)

240 SERIES 4 CYLINDER (Cont.)

VALVE SPRINGS

Removal & Installation - With cylinder head removed, compress valve springs using suitable valve spring compression tool, and remove valve retainers. Disassemble valve spring components and place valves in order in suitable valve rack. To install, place valves in position, fit valve guide seal, valve spring, upper washer and retainer.

VALVE SPRING INSTALLED HEIGHT

Valve spring ends must be square. Installed height of valve spring cannot exceed specifications. Measure spring height from base of spring pad on cylinder head to underside of spring retainer.

ROCKER ARM ASSEMBLY

Remove all hoses, electrical leads, and mechanical linkage. Remove rocker arm cover, rocker arm shaft assembly, and push rods. Check rocker arm shaft and push rods for excessive wear. Rocker arms can be rebushed if wear exceeds .004" (.10 mm) by pressing out old bushing, using a suitable tool (SVO 1867). Ream new bushing to accurate fit on rocker arm shaft. Oil hole in bushing should be aligned with oil hole in rocker arm. Grind rocker arm tips, if necessary, to ensure correct angle or surface.

VALVE CLEARANCE ADJUSTMENT

Valve clearance is to be adjusted with engine off. This procedure may be done with engine warm or cold. Valve clearance adjustment setting of .016-.018" (.40-.45 mm) is the same for both intake and exhaust valves. Turn crankshaft until

No. 1 piston is in firing position, No. 4 rockers balanced, and crankshaft pulley is on "0". Adjust valves in the following sequence:

Valve Adjusting Sequence		Adjust
Balance ①		
No. 4	No. 1
No. 2	No. 3
No. 1	No. 4
No. 3	No. 2

① - Balance = Exhaust valve has just closed and intake valve is about to open.

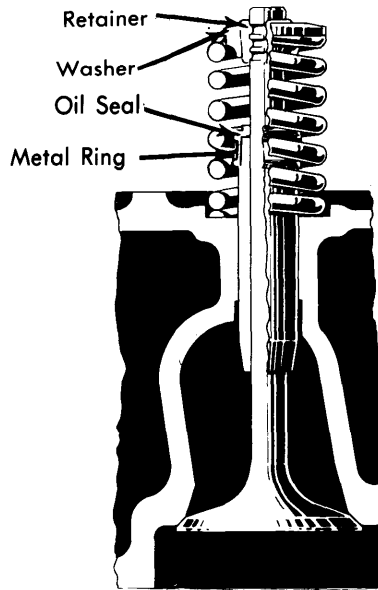

Fig. 3 Valve & Guide Assembly

PISTONS, PINS, RINGS						
Engine	PISTONS	PINS		RINGS		
	Clearance In. (mm)	Piston Fit In. (mm)	Rod Fit In. (mm)	Rings	End Gap In. (mm)	Side Clearance In. (mm)
B 20 F	.0004-.0012 (.010-.030)	Push Fit	Push Fit	All	.016-.022 (.40-.55)	.0016-.0028 (.040-.072)

OIL PAN

Removal - Raise vehicle and support with safety stands. Remove splash guard from under engine. Drain oil. Remove oil cooler line clamp and remove brace (automatic transmissions only). Remove attaching bolts and oil pan.

Installation - Install new gasket and oil pan to cylinder block. *NOTE - Gasket is marked "BLOCKSIDA" which should face block or is provided with an extrusion which must face starter motor flange.* Install brace, clamp, and splash guard. Fill engine with oil.

PISTON & ROD ASSEMBLY

Removal - Remove cylinder head and oil pan. Check to ensure that connecting rods and rod caps are marked correctly to reinstall in original location. Remove carbon ridge from cylinder bores. Remove rod cap, then remove piston and connecting rod assembly and install rod cap to its respective assembly.

Installation - Lubricate all internal surfaces with engine oil before assembly. Make sure notch in piston crown is facing front of engine, and connecting rod marking should face away from camshaft side. Install ring compressor tool onto piston, and fit piston and connecting rod assembly into block. Tap lightly on piston with wooden handle while guiding connecting rod onto crankshaft. Install rod cap and tighten bolts. Install oil pan and cylinder head.

240 SERIES 4 CYLINDER (Cont.)

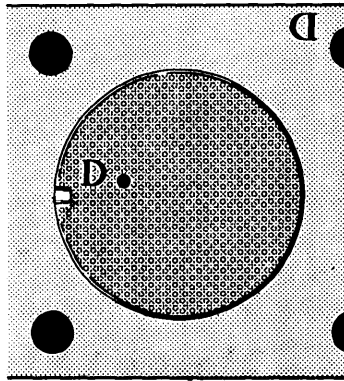

← Front Of Engine

Fig. 4 Installation Marks for Piston & Engine Block

FITTING PISTONS

Measure piston diameter at right angle to piston pin bore and .25" (7 mm) from lower edge. Measure cylinder bore at several positions. If difference exceeds clearance specifications, oversize pistons are available.

PISTON PINS

Piston pins are available in .002" (.05 mm) oversize from standard diameter. If replacement oversize pins are needed, piston pin hole should be reamed out to correct measurement using

suitable reaming tool. Use reamer fitted with pilot guide, take only small cuts at a time. Pin fit is correct when pin can be pushed through connecting rod hole by hand, with only light resistance.



Fig. 5 Thumb Pressure Piston Pin Fit

CRANKSHAFT MAIN & CONNECTING ROD BEARINGS							
Engine	MAIN BEARINGS			CONNECTING ROD BEARINGS			
	Journal Diam. In. (mm)	Clearance In. (mm)	Thrust Bearing	Crankshaft End Play In. (mm)	Journal Diam. In. (mm)	Clearance In. (mm)	Side Play In. (mm)
B 20 F	2.4981-2.4986 (63.451-63.464)	.0011-.0033 (.028-.083)0018-.0054 (.047-.137)	2.1255-2.1260 (53.987-54.000)	.0012-.0028 (.029-.071)	.006-.014 (.15-.35)

MAIN & CONNECTING ROD BEARINGS

Removal & Installation - 1) Remove oil pan and related parts. See *Oil Pan Removal*. Identify and mark connecting rod caps and main bearing caps to ensure correct replacement.

2) Remove connecting rod caps and push pistons towards top of cylinders. Remove main bearing caps (one at a time) and thoroughly clean all bearing surfaces.

3) Measure all journals, using a micrometer. Out-of-roundness on connecting rod bearings should not exceed .003" (.07 mm) and on main bearings, it should not exceed .002" (.05 mm). If values obtained are close to, or in excess of wear limits, crankshaft must be reground to next suitable undersize.

4) If all journals check out to standard size, refit with replacement bearings. Reinstall main bearing caps, refit connecting rods to crankshaft and tighten all nuts and bolts to specifications. Reassemble engine in reverse order of removal.

REAR MAIN BEARING OIL SEAL

Removal & Installation - 1) Remove transmission, clutch, and flywheel from engine. Remove two bolts for oil pan (in flange). Slacken a bolt on either side of flange, to relieve oil pan pressure against flange. Remove the flange. Use a suitable drift (SVO 2817) to remove oil seal.

2) Clean flange area thoroughly and inspect seal mating surface of crankshaft. Install new seal to flange using drift (SVO 2817). **NOTE** - If a new crankshaft has been installed, screw center bolt of tool in fully and install seal to its outer position in flange. If crankshaft has not been replaced, install seal with center bolt of tool screwed out a couple of turns.

3) Oil new seal and install flange with new gasket to cylinder block. Install attaching bolts and tighten. Install oil pan attaching bolts and tighten. Install flywheel, clutch, and transmission.

240 SERIES 4 CYLINDER (Cont.)

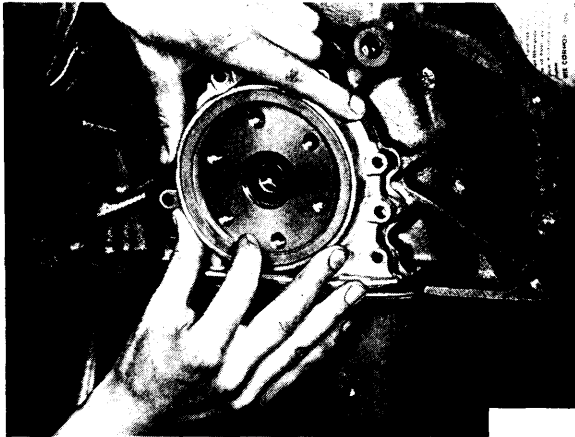

Fig. 6 Installing Rear Main Oil Seal Flange to Engine Block

ENGINE FRONT COVER

Removal — Remove fan shroud attaching screws and position shroud towards rear of engine. Loosen fan belt, remove fan pulley and shroud. Remove crankshaft pulley and water pump pulley. Loosen several front bolts for oil pan to aid in front cover removal. Remove front cover attaching bolts, then remove front cover. Remove snap ring, washer, and felt ring.

Installation — Replace front cover gasket. Ensure that oil drain hose in casing is open. Place cover in position and install bolts but do not tighten. Center cover using alignment sleeve (SVO 2438). Turn tool while tightening bolts and adjust position of cover so tool is not jammed. Fit new felt ring, washer, and snap ring. Push into position using centering tool and check to ensure that snap ring is in groove. Install remaining component in reverse of removal procedure.

FRONT COVER OIL SEAL

Removal — Remove fan shroud attaching screws and position shroud towards rear of engine. Loosen fan belt, remove fan pulley and shroud. Remove crankshaft pulley and water pump pulley. Remove crankshaft pulley. Remove snap ring, washer, and felt ring.

Installation — Install a new felt ring, washer and snap ring. Ensure that snap ring is in its groove. Install remaining components in reverse of removal procedure.

ENGINE OILING

Crankcase Capacity — 3.9 qts. including filter.

Oil Filter — Full-flow canister, disposable type.

Normal Oil Pressure — 36-85 psi @ 2000 RPM with engine hot.

ENGINE OILING SYSTEM

Engine utilizes a force-feed lubricating system. Oil is moved through oil pump to oil filter located on outside of engine block assembly. Lubricant is forced from filter to drilled gallery in center of block where oil moves under pressure to main bearings. Main bearings are drilled to pass lubricant on to rod bearings and to camshaft bearings. Oil from camshaft bearings is pushed up into head assembly where it lubricates

CAMSHAFT			
Engine	Journal Diam. In. (mm)	Clearance In. (mm)	Lobe Lift In. (mm)
B 20 F	①		
Front	1.8494-1.8504 (46.975-47.000)	.0008-.0030 (.020-.075)
Mid	1.6919-1.6929 (42.974-43.000)	.0008-.0030 (.020-.075)
Rear	1.4557-1.4567 (36.975-37.000)	.0008-.0030 (.020-.075)

① — End play is .0008-.0024" (.02-.06 mm).

TIMING GEAR REPLACEMENT

Remove engine front cover. Remove hub from crankshaft using a gear puller (SVO-2440). Remove camshaft nut and remove camshaft gear using a gear puller (SVO 2250). Pull crankshaft gear off using a gear puller (SVO 2405). Screw out oil nozzle and clean it. To install, reverse removal procedure, aligning timing marks as shown in illustration. Backlash and camshaft end play are determined by a spacer behind camshaft gear. Check backlash at camshaft gear, and it must not exceed .0048" (.12 mm).

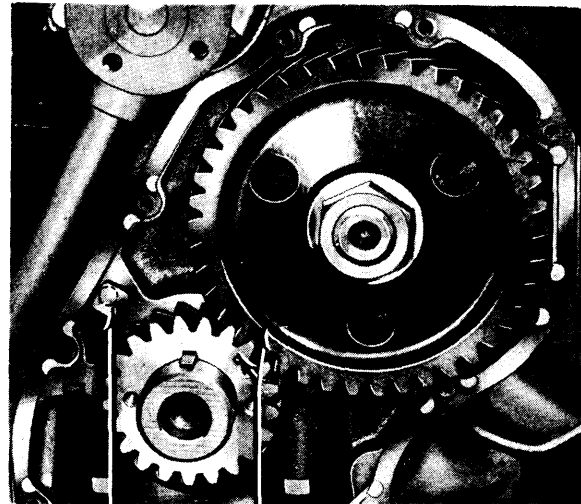

Oil Nozzle Timing Marks

Fig. 7 Aligning Timing Marks

rocker arm shaft and rocker arms. Push rods and valve lifters receive oil along with valve assembly. Oil nozzle at front of timing gear recess sprays gears with lubricant directly from main oil gallery. Cylinder walls and rings are lubricated by splash from connecting rods. Excess oil from all areas is returned to sump via drain holes in block assembly.

OIL PUMP

1) Remove oil pan and related parts. See *Oil Pan Removal*. Pull oil pump out of engine, disassemble and clean all parts thoroughly. Check all parts for excessive wear or signs of fatigue.

240 SERIES 4 CYLINDER (Cont.)

ENGINE OILING (Cont.)

2) Measure backlash (clearance) between pump gears. It should be .006-.014" (.15-.35 mm). Also measure end play of gears. Allowable end play is .0008-.0040" (.02-.10 mm). If any parts show excessive play, replace necessary components. Note that drive shaft and gear are a matched set and must be replaced as an assembly.

3) Reinstall oil pump, making sure that sealing rings on oil delivery pipe are securely in place. Be certain oil pump goes into groove in pump shaft. Replace oil pan and related components.

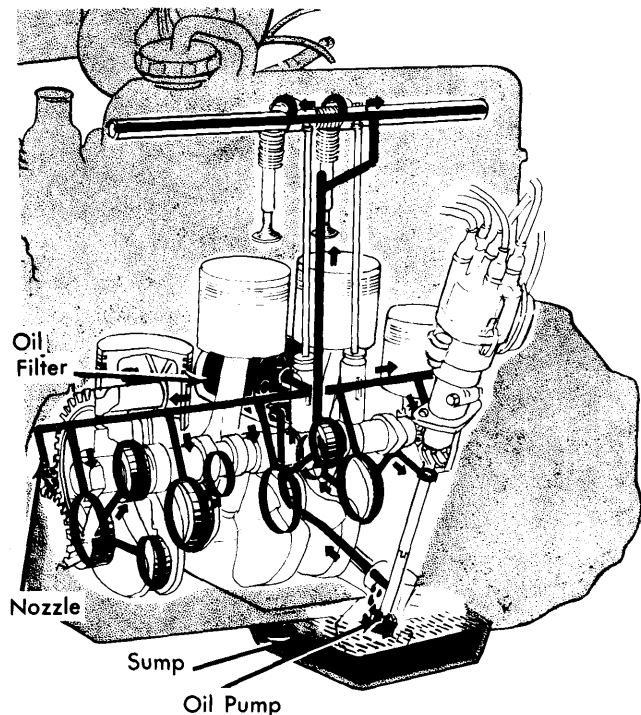

Fig. 8 Cutaway View of Engine Oiling System

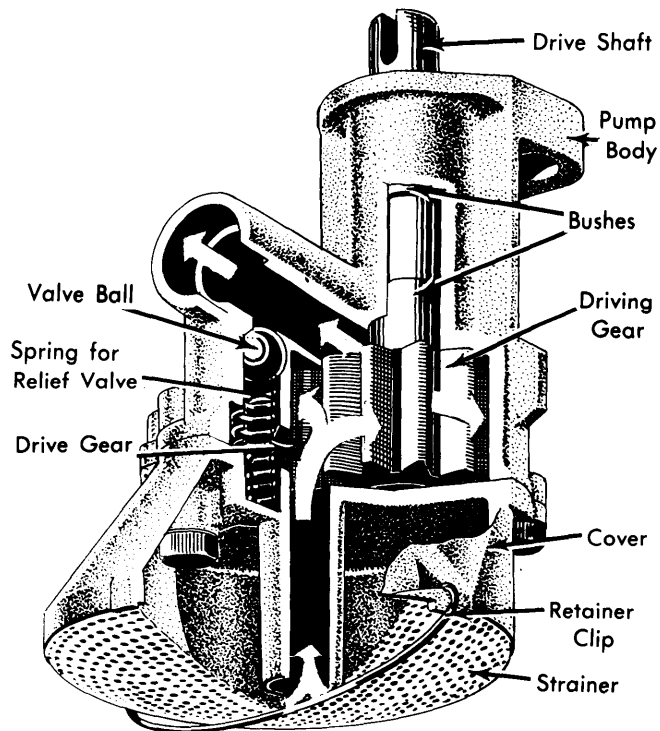

Fig. 9 Cutaway & Operational View of Oil Pump Assembly

ENGINE COOLING

WATER PUMP

Removal & Installation - 1) Disconnect lower radiator hose at engine to drain cooling system. Remove fan and fan shroud. Remove fan belt, spacer and pulley. Remove retaining screws for water pipes and pull pipes from pump. Remove water pump attaching bolts and remove water pump with gasket.

2) Clean all gasket surfaces thoroughly, install new gasket, then install water pump and attaching bolts. To install remaining components, reverse removal procedure.

Thermostat - Type 1 (marked "170") opens at 168-172°F (75-78°C); fully open at 192°F (89°C).
Type 2 (marked "82") opens at 177-181°F (81-83°C); fully open at 195°F (90°C).

TIGHTENING SPECIFICATIONS

Application	Ft. Lbs.(mkg)
Cylinder Head Bolts	
Step One	30 (4.1)
Step Two	60 (8.3)
Step Three	①65 (9.0)
Main Bearing Caps	87-94 (12-13)
Connecting Rod Caps	51-57 (7.0-7.9)
Flywheel Bolts	47-51 (6.5-7.0)
Spark Plugs	25-29 (3.5-4.0)
Camshaft Nut	94-108 (13.0-14.9)
Crankshaft Pulley Bolt	50-60 (7.0-8.3)
Oil Pan Bolts	6-8 (.8-1.1)

① - With engine warm.