

## TYPE 1 1600 CC 4 CYLINDER

GENERAL SPECIFICATIONS										
Year	Displ.		Carburetor	HP at RPM	Torque (Ft. Lbs. at RPM)	Compr. Ratio	Bore		Stroke	
	cu. ins.	cc					in.	mm	in.	mm
1975										
Type 1										
AH	96.9	1584	Fuel Inj	46@4000	72@2000	7.3-1	3.36	85.5	2.72	69
AK	96.9	1584	Fuel Inj	46@4000	72@2000	7.3-1	3.36	85.5	2.72	69

### ENGINE IDENTIFICATION

Engine identification is determined by first digits of serial number. Engine serial number is stamped on crankcase under generator support flange

**Application** ..... **Engine Code**  
Type 1 ..... AK or AH

### ENGINE REMOVAL

1) Disconnect battery ground cable and remove air cleaner. Disconnect electrical connections from generator, coil, oil pressure switch, and fuel injection. Disconnect accelerator cable at fuel injection and preheating air control cable (if equipped).

2) If equipped with Automatic Stick Shift, disconnect cable from control valve and vacuum hose from carburetor and intake manifold. Disconnect ATF pressure pipe and position so that fluid does not run out. Disconnect and plug ATF suction pipe.

3) Remove upper engine mounting nuts, accessible from behind fan shroud. Disconnect and plug fuel line. Raise vehicle and support on stands. Disconnect heater cables and remove heater tubes from engine. Pull accelerator cable from guide tube.

4) If equipped with Automatic Stick Shift, remove four bolts from drive plate through hole in transmission case. Engine may be rotated to gain access to all bolts.

5) Place a floor jack under engine to support and remove two nuts from lower engine mounting studs. Pull back on engine slightly until engine clears transmission shaft. Lower engine taking care not to damage transmission shaft or clutch. Remove engine.

**NOTE** — On vehicles equipped with Automatic Stick Shift, hold torque converter in place with a clamp.

6) On manual transmission models, inspect clutch release bearing for damage. Coat transmission shaft with molybdenum-disulfide powder and lubricate starter shaft bushing with multipurpose grease. Install engine carefully to avoid damage to transmission shaft or clutch. To complete installation, reverse removal procedure, adjust accelerator cable and check ignition timing. On Automatic Stick Shift models, check ATF level.

### INTAKE MANIFOLD

1) Intake manifold can be removed with engine in vehicle. Remove hood, fan belt, and clamp securing generator to mount on crankcase.

2) Remove warm air duct from lower right side. Remove bolt securing thermostat to bracket and unscrew thermostat from control rod. Remove hoses from fan housing. Disconnect wires from generator and coil. Remove screws at side of fan housing and remove housing.

3) Disconnect fuel and vacuum lines from carburetor. Remove nuts securing manifold to cylinder heads and bolts securing pre-heating tube to muffler. Remove intake manifold with carburetor from vehicle.

4) To install reverse removal procedure. Use new gaskets and tighten all nuts and bolts uniformly.

### CYLINDER HEAD

**NOTE** — Engine must be removed from vehicle, and manifolds removed, before removing cylinder heads. If cylinders are not to be removed, use retaining device to keep cylinders from pulling free.

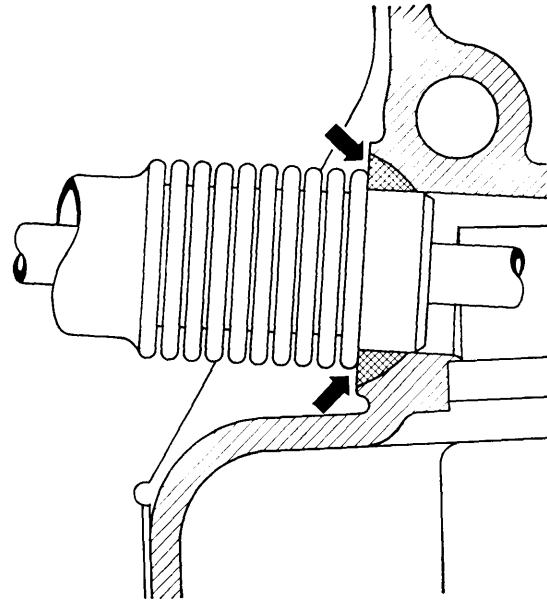

Fig. 1 Push Rod Tube Installation with Detail of Seal Fit

**Removal** — 1) Remove engine and intake manifold as previously outlined. Remove muffler and heat exchangers. Disconnect spark plug wires at spark plugs. Remove deflector cover plates from under cylinder cover plates and remove cylinder cover plates.

2) On fuel injected engines remove lower left side warm air duct. Remove bolt securing thermostat to bracket and unscrew thermostat from control rod. Disconnect rod from control lever at top.

# Volkswagen Engines

## TYPE 1 1600 CC 4 CYLINDER (Cont.)

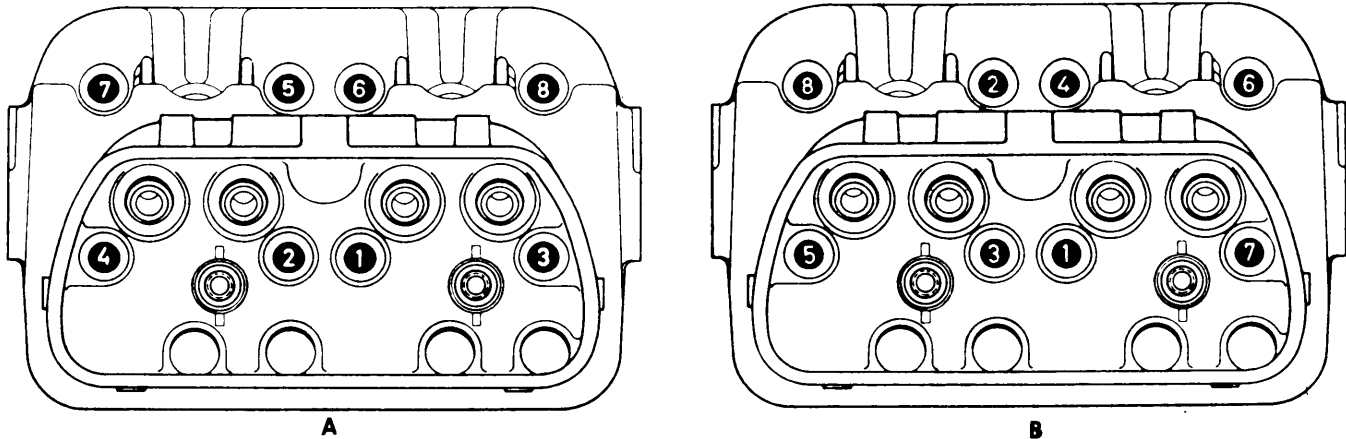

Fig. 2 Step One and Two for Cylinder Head Tightening Sequence — Volkswagen 1600 cc

3) Remove rocker arm cover with gasket and remove rocker arm assemblies. Remove push rods, keeping in order for reassembly. Loosen cylinder head nuts gradually working in sequence from outside toward center and remove cylinder head.

**Installation** — 1) Install new seals on pushrod tubes. Install cylinder head with new cylinder seals and position pushrod

tubes with seams facing upward. Push head onto cylinders to hold pushrod tubes.

2) Install cylinder head washers and nuts to studs and tighten just enough to hold head and pushrod tubes in place. Uniformly tighten nuts in sequence shown in illustration "A" to 7 ft. lbs., then tighten in sequence shown in illustration "B" to required torque. Reverse removal procedure for remaining components. Adjust valves.

VALVES							
Engine & Valve	Head Diam. In. (mm)	Face Angle	Seat Angle	Seat Width In. (mm)	Stem Diameter In. (mm)	Stem Clearance In. (mm)	Valve Lift In. (mm)
1600 cc Int.	1.40 (35.6)	45°	45°	.055-.098 (1.40-2.49)	.3125-.3129 (7.938-7.948)	.009-.010 (.229-.254)	.....
Exh.	1.26 (32.0)	45°	45°	.055-.098 (1.40-2.49)	.3113-.3117 (7.907-7.917)	.009-.010 (.229-.254)	.....

### VALVE ARRANGEMENT

E-I-I-E (front to rear), both banks.

### VALVE GUIDE SERVICING

1) Place valve in valve guide with stem flush with end of guide. With dial indicator, measure valve rock at valve head. If rock exceeds .031" replace valve guide or valve. Valve guide with inside machined shoulder is exhaust.

2) To replace valve guide, drill guide with shouldered drill to depth of 1½-2" using slow speed drill. Drive guides down through cylinder head with suitable tool. Drive oversize guide from top of cylinder head using press. Pressure required should be 2000-4000 lbs. Ream guides to proper fit.

### VALVE STEM OIL SEALS

Coat valve stems with molybdenum-disulfide paste and insert in cylinder head. Slide valve stem seal over valve stem using a suitable guide (VW699).

VALVE SPRINGS			
Engine	Free Length In. (mm)	PRESSURE Lbs. @ In. (kg @ mm)	
		Valve Closed	Valve Open
1600 cc Int. & Exh.	.....	117-184@1.22 (53.07-83.46@30.99)	.....

### VALVE SPRINGS

**NOTE** — Valve spring may be removed with cylinder head installed. Apply constant air pressure (minimum 85 psi) to cylinder through spark plug hole to hold valve in place while compressing spring.

**Removal** — Remove cylinder head cover and rocker arm shaft. Install suitable valve spring compressor tool (VW311H

## TYPE 1 1600 CC 4 CYLINDER (Cont.)

with cylinder head removed, VW653/2 with cylinder head installed). Compress spring retainer and spring and remove valve keepers. Release compressor and remove spring retainer and spring.

**Installation** — Install valve, valve spring, valve stem oil seal, and valve spring retainer. *NOTE* — Install spring with closely spaced coils against cylinder head. Compress spring with suitable compressor and install valve keepers.

### ROCKER ARM ASSEMBLY

- 1) Remove valve cover. Remove nuts from rocker arm studs and remove rocker arm assembly. Remove clips from end of shaft and remove washers, rocker arms and shaft supports.
- 2) Inspect shaft, supports and rocker arms for wear. Inspect sides of rocker arms and supports for wear. Smooth sides with emery paper before installing if worn.
- 3) To assemble reverse removal procedure. Install new seals on rocker arm studs, and reverse removal procedure to install. Adjust valve clearance.

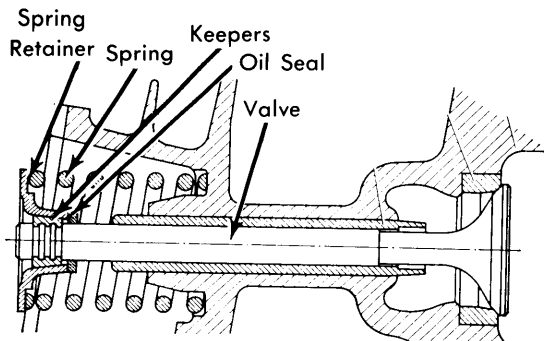

Fig. 3 Sectional View of Valve with Related Parts

### VALVE CLEARANCE ADJUSTMENT

Valve clearance is checked or adjusted with engine cold. Rotate engine until piston of valve being adjusted is at TDC of

compression stroke. Both valves can be adjusted at same time. Adjust both intake and exhaust valves to .006".

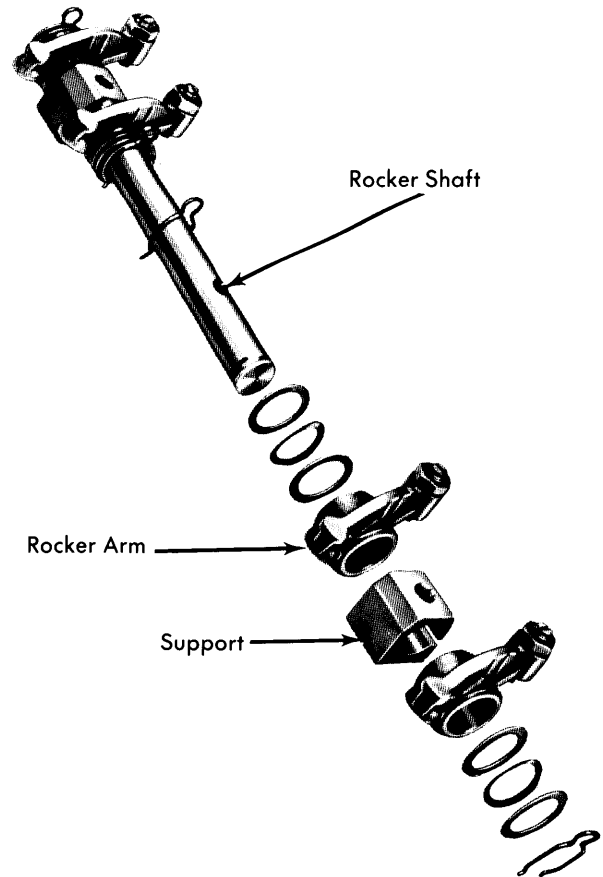

Fig. 4 Expanded View of 1600 cc Rocker Arm Assembly

PISTONS, PINS, RINGS						
Engine	PISTONS	PINS		RINGS		
	Clearance In. (mm)	Piston Fit In. (mm)	Rod Fit In. (mm)	Rings	End Gap In. (mm)	Side Clearance In. (mm)
1600 cc	.0016-.0024 (.041-.061)	①	.0004-.0008 (.010-.020)	1	.012-.018 (.31-.46)	.0027-.0039 (.069-.099)
				2	.012-.018 (.31-.46)	.0019-.0028 (.048-.071)
				3	.010-.016 (.25-.41)	.0012-.0020 (.030-.050)

① — Push fit with piston heated to approximately 176°F.

### CYLINDERS

**Removal** — Remove engine and remove cylinder head. *NOTE* — Mark cylinders to insure they are reinstalled in original position. Remove deflector plates from bottom of cylinders and pull cylinders from pistons.

**Installation** — 1) Check seating surfaces of cylinders on both ends. Make sure seating areas are perfectly clean and true before installing cylinders. Stagger ring gaps 90° apart so that oil ring gap faces upward when cylinder is installed.

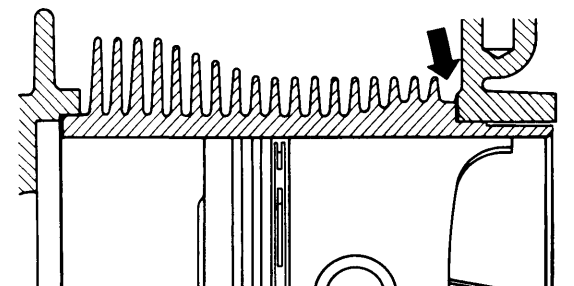

Fig. 5 Shows Correct Position of Cylinder Seal

## TYPE 1 1600 CC 4 CYLINDER (Cont.)

2) Apply oil to cylinder, piston, rings and piston pin. Compress rings with suitable ring compressor (VW123). Install new sealing gasket on crankcase side and slide cylinder over piston.

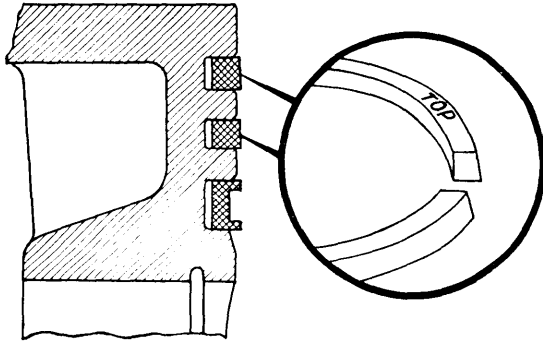

Fig. 6 Installation of Compression Rings 1 and 2

3) Make sure studs do not contact cooling fins when cylinder is completely seated against crankcase. Install cylinder deflector plates and remaining components in reverse of removal.

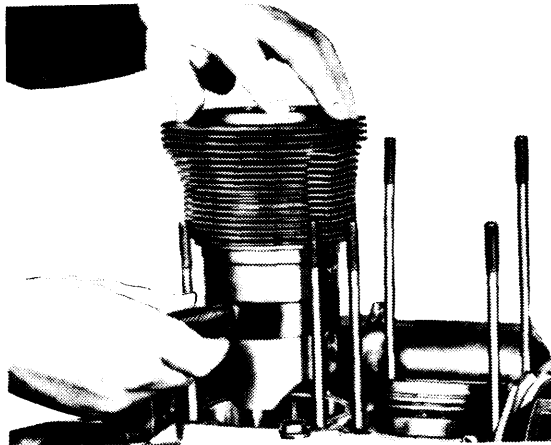

Fig. 7 Placing Cylinder Assembly into Case

## FITTING PISTONS

1) With piston and cylinder removed, measure clearance between piston and cylinder. Check piston size at bottom of skirt and 90° to piston pin. Check cylinder size at several points throughout cylinder, using largest reading to determine clearance.

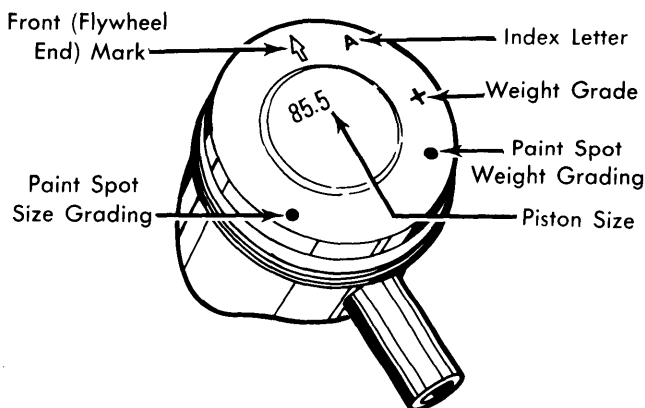

Fig. 8 Top View of Piston with Detail of Piston Markings

2) If clearance exceeds .008" replace piston and cylinder as a set. New piston must be of same weight grade as original or within 10 g of original piston weight. Piston size, weight, and installation position are marked on top of piston.

NOTE — Piston alone may be replaced with one of matching size. Only pistons of same size and weight grade should be installed in same engine.

3) New piston rings are size graded to match piston-cylinder sets. Measure ring gap with ring installed approximately 1/4" from bottom of cylinder.

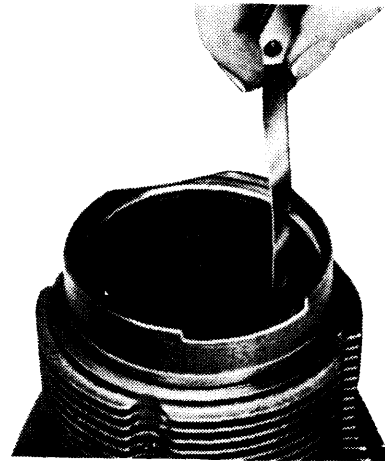

Fig. 9 Using a Feeler Gauge to Measure Ring Gap

4) Install rings on piston and measure ring side clearance using feeler gauge. If clearance exceeds .005" on top ring or .004" on second or oil ring, piston must be replaced.

## PISTON PINS

**Removal** — Remove cylinders and mark pistons before removing for proper installation. Using suitable pliers (VW122b), remove piston pin circlips and push piston pin out of piston using suitable tool (VW207).

**Installation** — 1) Check fit of pin in piston. Piston pin should be light push fit with piston 68-167°F. If pin is too loose, both pin and piston must be replaced. Check clearance of pin in rod. If clearance exceeds .0016" replace piston pin and rod bushing. See *Piston Pin Bushing Replacement*.



Fig. 10 Using a Feeler Gauge to Measure Ring Clearance

## TYPE 1 1600 CC 4 CYLINDER (Cont.)

2) Install one circlip in piston on side facing flywheel. Position piston on connecting rod and push piston pin through piston. Replace remaining circlip. **NOTE** — *Piston may be heated to ease pin installation.* Replace remaining components in reverse of removal.

### PISTON PIN BUSHING REPLACEMENT

1) At normal temperature, piston pin should push fit in connecting rod. If side clearance is felt with a new pin installed,

bushing must be replaced and reamed to correct fit with a new piston pin.

2) Press bushing out using a suitable mandrel and components (VW402, 409, 421 and 416B). Install new bushing using same procedure and tools used for removal.

3) Drill through oil holes in connecting rod. Ream bushing to .8664-.8667", bushing should be free of chatter marks when reaming is completed. Piston pin should push fit into bushing without oil.

CRANKSHAFT MAIN & CONNECTING ROD BEARINGS							
Engine	MAIN BEARINGS				CONNECTING ROD BEARINGS		
	Journal Diam. In. (mm)	Clearance In. (mm)	Thrust Bearing	Crankshaft End Play In. (mm)	Journal Diam. In. (mm)	Clearance In. (mm)	Side Play In. (mm)
1600 cc Journal No. 1	2.1640-2.1648 (54.966-54.986)	.0016-.0039 (.041-.099)	No. 1	.0027-.0051 (.069-.130)	2.1653 (54.999)	.0008-.0028 (.020-.071)	.004-.016 (.10-.41)
2	2.1640-2.1648 (54.966-54.986)	.0012-.0035 (.031-.089)					
3	2.1640-2.1648 (54.966-54.968)	.0016-.0039 (.041-.099)					
4	1.5739-1.5748 (39.977-39.999)	.0020-.0039 (.051-.099)					

Crankcase must be taken apart to replace connecting rods, connecting rod bearings and main bearings. It is also necessary to disassemble crankcase to remove crankshaft, camshaft, and camshaft bearings.

### CRANKCASE DISASSEMBLY

1) Remove engine from vehicle and remove cylinder heads, cylinders and pistons as previously outlined. Remove flywheel or drive plate, distributor, fuel pump, distributor drive, distributor drive washer and oil cooler.

2) Remove front pulley nut and remove pulley using suitable puller (VW203). Remove generator support housing and metal shroud from front of engine.

3) On all models remove oil pump cover and pull oil pump from crankcase using a suitable puller (VW201). Remove retaining plate and screen from bottom of motor. Remove nuts and bolts securing crankcase halves and separate.

**CAUTION** — Use a rubber hammer to separate crankcase halves, do not insert any kind of tool between sealing edges.

4) Remove camshaft and crankshaft. Remove crankshaft oil seal and cam plug. Remove number two bearing halves from both sides of crankcase and remove bearing dowel pins. Remove cam bearings if equipped. Remove oil pressure relief valve.

### CRANKCASE ASSEMBLY

1) Thoroughly clean and inspect crankcase halves for wear or cracking. Assemble empty crankcase halves and tighten nuts to specifications. Measure crankshaft bearing bores with an inside micrometer. Maximum size for bearing bores 1 through 3 is 2.5601" and maximum size for number 4 bearing bore is 1.9700". If necessary slightly chamfer edges of bearing bores.

2) Flush out all oil passages and blow out with compressed air. Make sure oil suction tube and all studs are tight in crankcase halves. Check valve tappets and bores in crankcase. Maximum clearance is .0047".

3) Insert valve tappets and crankshaft bearing dowel pins. Install camshaft bearings if equipped. Install number 2 bearing halves. Install crankshaft and connecting rod assembly, making sure bearings line up with dowel pins.

4) Install camshaft with "O" on cam gear centered between two teeth with punch marks on crankshaft gear. Install cam plug using sealer. Spread a thin coat of sealer on sealing edges of crankcase halves, making sure sealer does not enter oil passages.

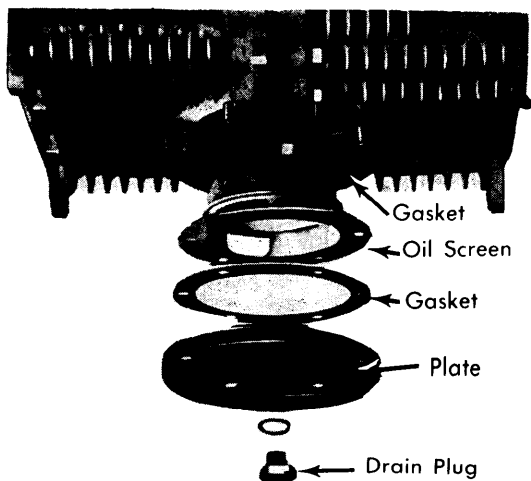

Fig. 13 Bottom View Showing Oil Strainer and Components

## TYPE 1 1600 CC 4 CYLINDER (Cont.)

5) Install "O" ring on large crankcase studs and push "O" ring into beveled portion of crankcase. Join crankcase halves together and lightly tighten nuts. Tighten M8 nut next to M12 nut near number 1 bearing then tighten all M12 nuts. Tighten remaining nuts and bolts.

6) Check crankshaft for freedom of movement. Install oil pressure relief valve. Install pistons, cylinders and cylinder heads as previously outlined.

7) On all models install all components except distributor and distributor drive in reverse of removal order. Set engine on number one firing position. Place distributor drive washer on a long screwdriver. Insert screwdriver into bottom of distributor hole, drop washer and center in bottom of hole with screwdriver.

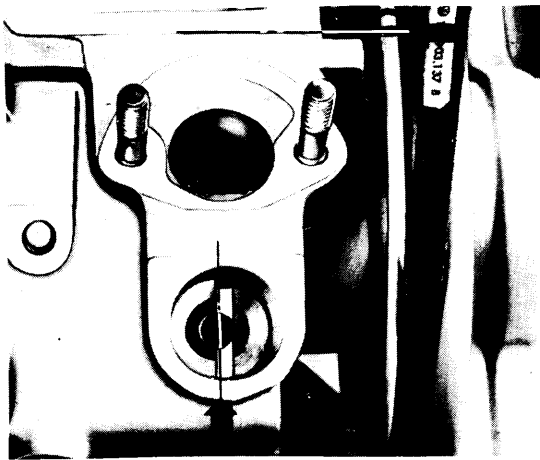

Fig. 11 1600 cc Distributor Drive Installation

8) Insert distributor drive with slot at 90° with crankshaft and small segment of slot toward pulley.

#### MAIN & CONNECTING ROD BEARING SERVICE

1) Split crankcase and remove crankshaft and connecting rod assembly as previously outlined. Attach crankshaft to a suitable holding fixture (VW310A).

2) Remove Woodruff key, oil thrower and number 4 bearing. Remove connecting rods and bearings. Remove snapping from end of crankshaft.

3) Press distributor drive gear, spacer and crankshaft gear from crankshaft. Remove number 3 bearing. Thoroughly clean crankshaft and blow out all oil passages with compressed air.

4) Check crankshaft for runout, maximum runout is .0011". Check crankshaft journals for out-of-round, maximum out-of-round is .0011". If excessive out-of-round conditions exist, crankshaft must be ground to next undersize.

5) Bearings for undersize crankshafts are available in .010, .020 and .030" undersize. Connecting rod bearing journals are also available in same undersizes.

6) Clean and inspect connecting rods. If bushing has been determined to be worn excessively, install new bushing. See *Piston Pin and Piston Pin Bushing Replacement*. Check connecting rod for twist and bending.

7) If connecting rod is replaced, make sure there is no more than 10 grams difference in weight between new and old connecting rods.

8) Main bearing clearance is checked by the Plastigage method. Place a piece of Plastigage wire across crankshaft journal. Install bearings on crankshaft and install crankshaft in empty crankcase halves. Bolt crankcase together at specified torque. Do not turn crankshaft. Separate crankcase and remove crankshaft. Remove bearings and compare flattened wire to scale on Plastigage package. Compare to specified clearance.

9) If clearance is more than specified, crankshaft can be ground to .010", .020" and .030" undersize. Replacement bearings of appropriate size must be used. This same procedure is used when determining connecting rod bearing clearance.

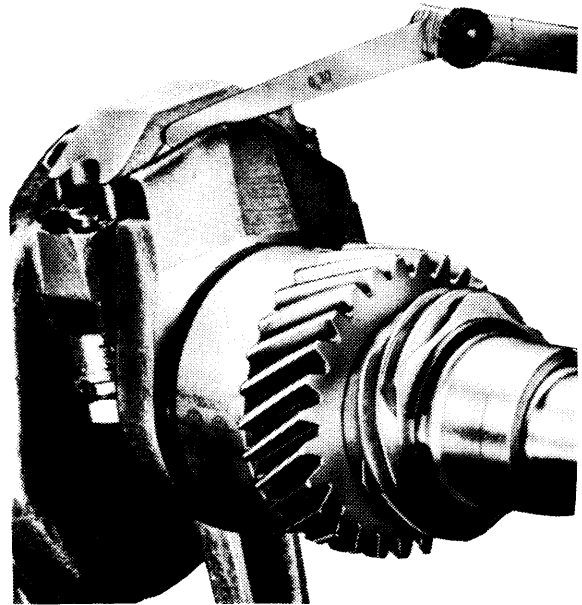

Fig. 12 Using a Feeler Gauge to Check Connecting Rod Side Clearance

10) Install bearing halves in rod and rod cap. Install on crankshaft with numbers on rod and rod cap together and with forged mark on rod up when crankshaft is installed. Tighten rod bolts or nuts to specifications. Check rod side clearance.

11) Oil and install number 3 bearing on crankshaft with dowel pin hole toward flywheel. Press on crank gear, spacer and distributor drive gear. Install snap ring. Oil and install number 4 bearing with groove toward oil thrower. Install oil thrower and Woodruff key.

12) Oil and install number 1 bearing and install crankshaft in crankcase as previously outlined.

#### THRUST BEARING ALIGNMENT

1) Crankshaft endplay must be adjusted with crankshaft oil seal removed. Install two shims, flywheel gasket (paper or metal) and flywheel.

2) Correct end play is .0028-.0051" and must not exceed .006". Mount dial indicator to crankcase so back and forth movement of crankshaft can be determined. Rock crankshaft back and forth and determine thickness of third shim.

## TYPE 1 1600 CC 4 CYLINDER (Cont.)

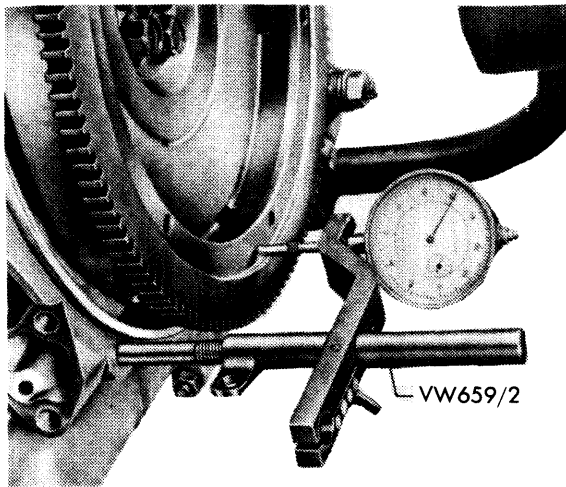

Fig. 18 Checking Crankshaft End Play with Dial Gauge

3) Install third shim, oil seal, and flywheel with gasket. Recheck end play. Following shim sizes are available:

Millimeter Marking (Etched in Shim)	Inch Equivalent
0.24 mm .....	.0094"
0.30 mm .....	.0118"
0.32 mm .....	.0126"
0.34 mm .....	.0133"
0.36 mm .....	.0142"

### MAIN BEARING OIL SEAL SERVICE

1) Remove flywheel and pry out old seal. Clean recess in crankcase and coat with a thin film of sealer.

2) Install a new seal using a suitable installer (VW240D). Make sure seal is squarely seated in recess.

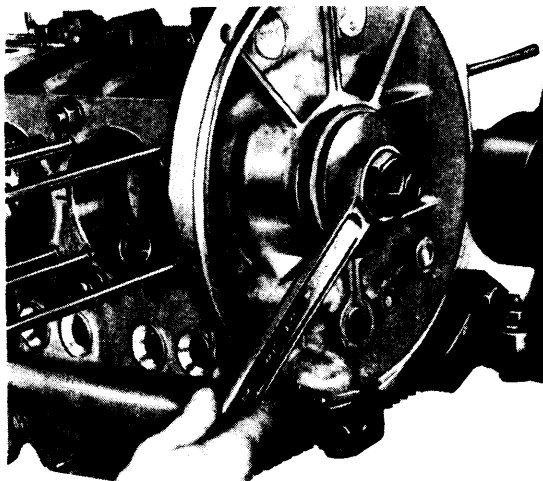

Fig. 19 Crankshaft Oil Seal Installation with Special Tool

3) Lubricate contact surface or seal and install flywheel. Tighten flywheel retaining nut to specification.

CAMSHAFT			
Engine	Journal Diam. In. (mm)	Clearance In. (mm)	Lobe Lift In. (mm)
1600 cc	.9837-.9842 (24.986-24.999)	.0008-.0019 (.020-.048)	.....

### CAMSHAFT REMOVAL

1) Split crankcase and remove camshaft as previously outlined. Clean camshaft and inspect riveted joint between camshaft and gear.

2) Inspect camshaft lobes and bearing journals for excessive wear. Maximum wear for bearing journals is .0015". Check camshaft runout on number 2 bearing journal. Maximum runout is .0016".

3) Check backlash between camshaft and crankshaft gears. Correct backlash is 0-.002". If backlash is incorrect, camshafts with different pitch radius are available. Pitch radius is stamped on inner face of gear.

### CAMSHAFT END THRUST

Camshaft end play is checked with camshaft installed in crankcase half. Measure back and forth movement of camshaft with a dial indicator. If end play exceeds .0062", replace camshaft or camshaft bearings. Correct end play is .0016-.0051".

Engine	VALVE TIMING			
	INTAKE		EXHAUST	
	Open (BTDC)	Close (ABDC)	Open (BBDC)	Close (ATDC)
All	7.5°	37°	44.5°	4°

### VALVE TIMING

Install camshaft with "O" stamped in tooth on outside of camshaft gear between two teeth with punch marks on crankshaft gear.

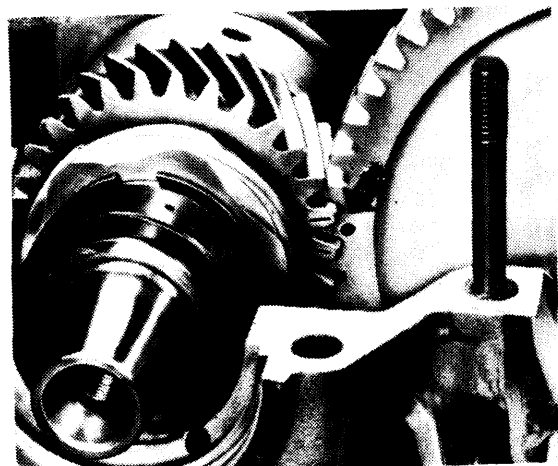

Fig. 20 Correct Position of Camshaft Timing Gear

## TYPE 1 1600 CC 4 CYLINDER (Cont.)

### ENGINE OILING

**Oil Capacity** — 2.65 Qts.

**Normal Oil Pressure** — Minimum oil pressure at 550 RPM is 7 psi. At 2500 RPM minimum oil pressure is 28 psi and standard oil pressure is 42 psi.

**Pressure Regulator Valves** — Oil pressure relief valve, used to protect oil cooler from excessive pressure, is located in crankcase to rear of oil pan. Oil pressure control valve, used to control oil pressure to bearings, is located in crankcase forward of oil pan. Oil pressure relief spring should have length of 1.73" at 12.3-16.0 lbs. load. Oil pressure control spring should have length of .795" at 6.8-8.4 lbs. load.

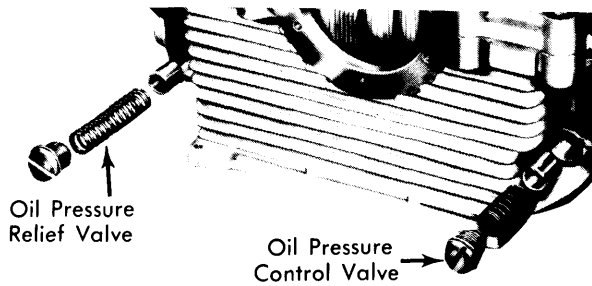

Fig. 14 Oil Pressure Regulator Valves Location

### ENGINE OILING SYSTEM

Full pressure lubrication system with gear type oil pump. Oil pump is mounted at front of engine and driven by the camshaft. Oil is pumped through oil cooler into oil passages. Crankshaft main and connecting rod journals oil through cross drilled holes in crankshaft. Oil is pumped to camshaft through oil passages that also lubricate valve tappets. Oil flows through tappets and into push rods to lubricate rocker arms and shafts. Valves and valve stems are lubricated by splash oil. Excess oil flows back into crankcase through push rod tubes. Cylinder walls, pistons and piston pins are oiled by splash oil.

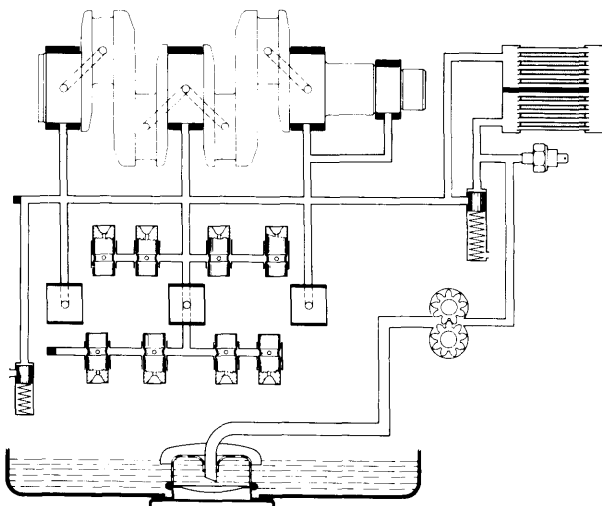

Fig. 15 Engine Lubrication Circulation Diagram

### OIL PUMP REPLACEMENT

**W/Man. Trans.** — 1) Remove crankshaft pulley and metal shroud from behind pulley.

2) Remove oil pump cover and gears. Pull pump housing from crankcase using a suitable puller (VW201). Check gear backlash and endplay.

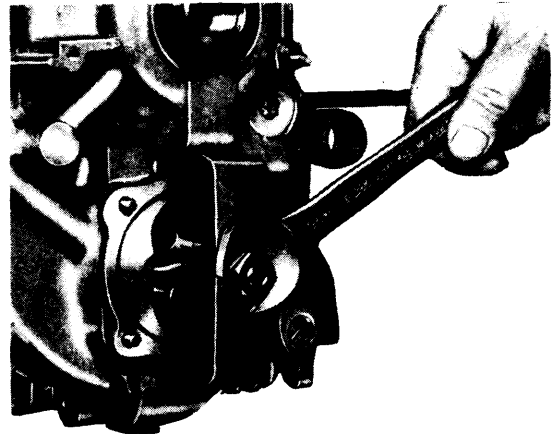

Fig. 16 Removing Oil Pump with a Puller Tool

3) Inspect pump body mating surfaces for wear or damage. Install pump body and gasket (without sealer) in crankcase. Insert a suitable pilot in housing in place of gear.

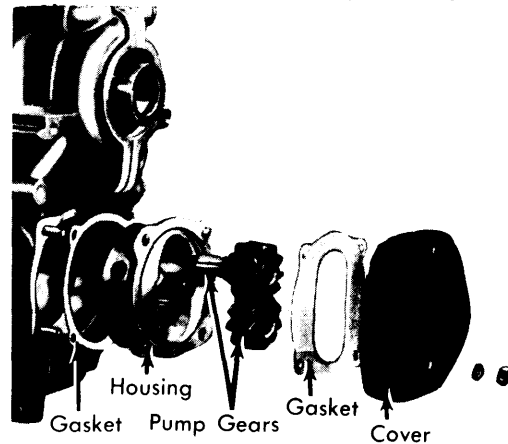

Fig. 17 Partially Disassembled View of Oil Pump

4) Rotate crankshaft 360° twice to center pump body with slot in camshaft. Remove pilot and install gears. Inspect cover and machine flat if necessary. Use new gasket (without sealer) and install cover. Tighten bolts and install remaining components as previously outlined.

**W/Auto. Stick Shift** — 1) Apply same procedures as outlined above, noting the following: Remove Woodruff keys to avoid damage to intermediate plate seals. If intermediate plate or front cover are damaged, replace complete oil pump.

### Oil Pump Specifications

Application	Measurement
Gear Backlash.....	0-.008" (0-.20 mm)
End Play Without Gasket (Max.).....	.004" (.10 mm)

## TYPE 1 1600 CC 4 CYLINDER (Cont.)

### ENGINE COOLING

#### COOLING SYSTEM

Engine is cooled by a radial fan mounted on end of generator and inside of upright shroud. Fan draws air in through large hole in fan shroud. Air is then directed over finned cylinders and cylinder heads by deflector plates. A thermostat is mounted under cylinders number one and two. Thermostat operates by opening and closing deflector plates in fan shroud.

#### FAN SHROUD

- 1) Removal of fan shroud can be accomplished with engine in or out of vehicle. Hood must be removed if shroud is to be removed with engine in vehicle. Remove heater hoses and fan belt.
- 2) Remove generator strap and wires to generator if engine is in vehicle. Pull coil wire from coil and remove distributor cap. Disconnect spark plug wires at spark plugs.
- 3) Remove screws from both sides of shroud. Remove bolt from bracket securing thermostat, accessible through hole in warm air duct on bottom of engine. Unscrew thermostat from connecting rod and pull shroud off with generator.
- 4) Reverse removal procedure to install. Check belt tension. See *Belt Tension Adjustment*. Adjust air control flap. See *Air Control Flap Adjustment*.

#### FAN REMOVAL

- 1) Remove fan shroud as previously outlined. Remove four bolts securing generator mount to shroud. Pull out generator and fan.
- 2) Remove nut from center of fan and remove fan, spacer washer and hub from generator. Reverse removal procedure to install. Distance between fan and cover should be approximately .079" (2.0 mm). Install spacer between hub and thrust washer to obtain this distance.

#### BELT TENSION ADJUSTMENT

Press in on belt firmly at midpoint. Belt should depress approximately .6". If adjustment is required, remove from generator pulley. Remove front half of pulley. Remove or add shims between pulley halves to obtain correct adjustment.

#### AIR CONTROL FLAP ADJUSTMENT

Remove right hand cylinder head cover plate. Lubricate all joints of linkage with molybdenum-disulfide paste. Press flaps into closed position. Tighten clamp screw on actuating lever. Connect long end of spring to flap and short end to actuating plate.

### TIGHTENING SPECIFICATIONS

Application	Ft. Lbs. (mkg)
Cylinder Heads.....	23 (3.18)
Connecting Rods.....	24 (3.32)
Crankcase Halves (8mm).....	14 (1.94)
Crankcase Halves (12mm).....	25 (3.46)
Rocker Shaft-To-Cylinder Head.....	18 (2.49)
Intake Manifold-to-Cylinder Head.....	14 (1.94)
Oil Pump-to-Crankcase.....	14 (1.94)
Oil Drain Plug.....	25 (3.46)
Oil Strainer-to-Crankcase.....	5 (.69)
Oil Cooler-to-Crankcase.....	5 (.69)
Oil Filler & Breather-to-Generator Stand.....	40 (5.53)
Flywheel-to-Crankshaft.....	253 (34.99)
Clutch-to-Flywheel.....	18 (2.49)
Converter-to-Driveplate.....	18 (2.49)
Engine-to-Transmission.....	22 (3.04)
Generator Pulley.....	43 (5.95)
Crankshaft Pulley.....	32 (4.42)
Fan Nut.....	43 (5.95)

# Volkswagen Engines

## TYPE 2 1800 CC 4 CYLINDER

GENERAL SPECIFICATIONS										
Year	Displ.		Carburetor	HP at RPM	Torque (Ft. Lbs. at RPM)	Compr. Ratio	Bore		Stroke	
	cu. ins.	cc					in.	mm	in.	mm
1975										
AW	109.5	1800	Fuel Injection	65@4200	92@3000	7.3-1	3.660	93	2.600	66
ED	109.5	1800	Fuel Injection	70@4800	70@2400	.....	3.660	93	2.600	66

### ENGINE IDENTIFICATION

Engine serial and code number is stamped on crankcase below breather and near ignition coil. First two digits indicate engine type.

Application	Code
Type 2 .....	ED,AW

### ENGINE REMOVAL

**Removal** – 1) Disconnect battery and remove air cleaner. Disconnect wiring from distributor, alternator regulator, oil pressure switch, fuel injection unit, transmission switch, trigger for ignition timing, and temperature sensor mounted in upper right hand side of engine compartment

2) Disconnect wire for backup lights at in-line fuse holder, near ignition coil, and remove ignition coil. Disconnect hose from activated charcoal filter canister. Disconnect wires and two hoses from vacuum advance cutoff valve near warm air fan.

3) Remove duct hoses connecting warm air fan with heat exchangers. Remove rear and side engine cover plates, and gravel guard from under rear bumper.

4) On vehicles with automatic transmission, remove ATF dipstick, loosen clamp nuts holding filler pipe and remove ATF filler pipe by turning counterclockwise.

5) Disconnect accelerator cable from throttle operating crossrod. On vehicles with automatic transmission, remove three bolts attaching torque converter to drive plate by turning engine to make bolts accessible through opening in converter housing.

6) Remove two upper engine-to-transmission bolts. Pull accelerator cable out of guide tube and disconnect fuel line from fuel pump. **CAUTION** – Plug fuel line to prevent fuel spillage.

7) Disconnect wires from starter solenoid and disconnect heater flap cables from heat exchangers. Pull off ducts connecting heat exchangers with vehicle interior. Install a suitable bar under transmission to support transmission (VW 785).

8) Remove two lower engine-to-transmission bolts. Place floor jack under engine and support engine. Remove bolts attaching engine bearer brackets to frame. Move engine to rear to clear transmission drive shaft and carefully lower to floor.

**NOTE** – On vehicles with automatic transmission install retaining strap across converter housing to prevent torque converter from falling off support tube.

9) To install engine, reverse removal procedure. Lubricate clutch release bearing, transmission drive shaft and starter drive bushing. Tighten engine-to-transmission bolts before tightening engine bearer bracket bolts. Engine bearer bracket must be vertical and parallel to engine fan housing.

### INTAKE MANIFOLD

**Removal** – 1) Fuel injection manifold can be removed with engine in vehicle. Remove air cleaner, hoses, and pressure switch.

2) Disconnect wires on fuel injectors and remove two screws. Pull injectors off with plate and retainer. Make sure locating bushings are removed from manifold. Disconnect hoses on injectors and remove.

3) Remove intake manifold cover plate. Remove nuts and washers securing manifold to cylinder heads. Lift up on manifold and pull from tubes on air distributor.

**Installation** – To install manifold, reverse removal procedure and note the following: Use new gaskets and tighten intake manifold mounting nuts uniformly. Make sure gray protective cap on injector is to rear and cap is to front.

### CYLINDER HEAD

**NOTE** – Engine must be removed from vehicle and manifolds removed, before removing cylinder heads. If cylinders are not to be removed, use retaining device to keep cylinders from pulling free.

**Removal** – 1) Remove rocker arm cover and gasket. Remove rocker arm shaft retaining nuts, loosening gradually one at a time to relieve spring tension evenly. Remove rocker arm assemblies.

2) Remove push rods, keeping in order for reassembly. Loosen cylinder head nuts gradually working in sequence from outside toward center.

## TYPE 2 1800 CC 4 CYLINDER (Cont.)

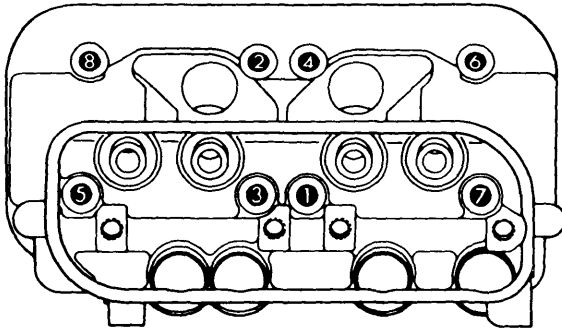

Fig. 1 1800 cc Cylinder Head Tightening Sequence

**Installation** - 1) Install new seals on pushrod tubes. Install cylinder head with new gaskets on cylinder head studs and position pushrod tubes with seams facing upward. Push head onto cylinders to hold pushrod tubes.

2) Install cylinder head washers and nuts to studs and tighten just enough to hold head and pushrod tubes in place. Uniformly tighten nuts to approximately 11 ft. lb. in sequence, then tighten in sequence again to 23 ft. lb. Reverse removal procedure for remaining components.

VALVES							
Engine & Valve	Head Diam. In. (mm)	Face Angle	Seat Angle	Seat Width In. (mm)	Stem Diameter In. (mm)	Stem Clearance In. (mm)	Valve Lift In. (mm)
1800 cc Int.	1.614 (41.00)	29.5	30°	.071-.087 (1.80-2.21)	.3125-.3129 (7.936-7.948)	.018 (.46)	.....
Exh.	1.338 (34.00)	45°	45°	.079-.098 (2.01-2.49)	.3508-.3512 (8.910-8.920)	.018 (.46)	.....

### VALVE ARRANGEMENT

E-I-I-E

### VALVE GUIDE SERVICING

1) Place valve in valve guide with stem flush with end of guide. With dial indicator, measure valve rock at valve head. If rock exceeds .035" (.89 mm), replace valve guide or valve. Valve guide with inside machined shoulder is exhaust.

2) To replace valve guide, drill guide with shouldered drill to depth of 1½-2" using slow speed drill. Drive guides down through cylinder head with suitable tool. Drive oversize guide from top of cylinder head using press. Pressure required should be 2000-4000 lbs. Ream guides to proper fit.

valve keepers. Release compressor and remove spring retainer and spring.

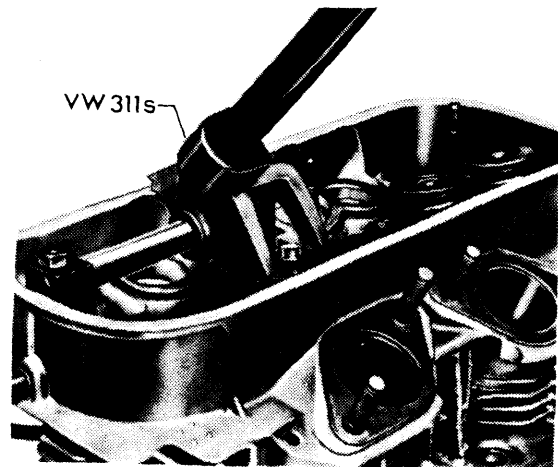

Fig. 2 Using Special Tool VW 311s to Remove Valve Spring

VALVE SPRINGS			
Engine	Free Length In. (mm)	PRESSURE Lbs. @ In. (kg @ mm)	
		Valve Closed	Valve Open
All Int. & Exh.	.....	168-186@1.14 (76.20-84.37@28.96)	.....

### VALVE SPRINGS

**NOTE** - Valve spring may be removed with cylinder head installed. Apply constant air pressure (minimum 85 psi) to cylinder through spark plug hole to hold valve in place while compressing spring.

**Removal** - Remove cylinder head cover and rocker arm shaft. Install suitable valve spring compressor tool (VW311s with cylinder head removed, VW653/2 with cylinder head installed). Compress spring retainer and spring and remove

**Installation** - Install valve, valve spring, and valve spring retainer. **NOTE** - Install spring with closely spaced coils against cylinder head. Compress spring with suitable compressor and install valve keepers.

### ROCKER ARM ASSEMBLY

1) With rocker arm assembly, push rod tubes, and valve tappets removed, check valve tappet face and sides for wear or scoring. If diameter of tappet is less than .9421" C23.929 mm), replace tappet.

# Volkswagen Engines

## TYPE 2 1800 CC 4 CYLINDER (Cont.)

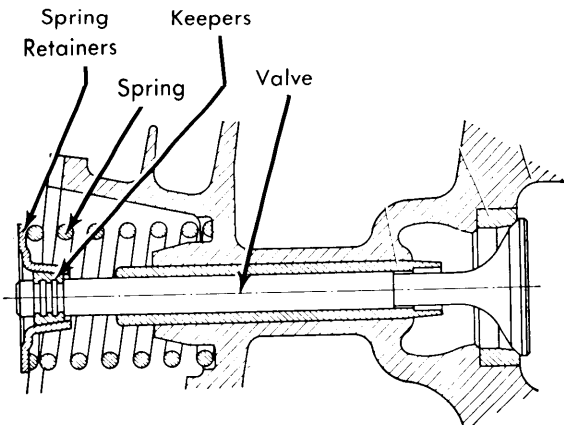

Fig. 3 Sectional View of Valve with Related Parts

2) Check rocker arms and shafts for wear. If inside diameter is more than .7890" (20.041 mm), replace rocker arm. If diameter is less than .7846" (19.929 mm), replace rocker shaft.

3) To install components, lubricate tappet with oil and insert in crankcase. Install push rod tubes with new seals. Slide shaft support stands on rocker shafts so slots face down when installed on engine.

**NOTE** — A new type rocker shaft spring is available (ends not ground). When using new type spring, thrust washers must be removed.

4) Install rocker arm assemblies and tighten nuts to specifications. Install push rod tube securing clip. Clip is secured to head by sliding into slots in rocker shaft support stands. Adjust valve clearance. See *Valve Clearance Adjustment*.

### VALVE CLEARANCE ADJUSTMENT

Valve clearance is checked or adjusted with engine cold. Rotate engine until piston of valve being adjusted is at TDC of compression stroke. Both valves can be adjusted at same time. Adjust both intake and exhaust valves to .006" (.15 mm).

PISTONS, PINS, RINGS						
Engine	PISTONS	PINS		RINGS		
	Clearance In. (mm)	Piston Fit In. (mm)	Rod Fit In. (mm)	Rings	End Gap In. (mm)	Side Clearance In. (mm)
All	.0016-.0023 (.041-.058)	⓪	.0004-.0012 (.010-.030)	1	.014-.021 (.35-.53)	.0023-.0035 (.058-.089)
				2	.014-.021 (.35-.53)	.0016-.0028 (.041-.071)
				3	.010-.016 (.25-.41)	.0008-.0019 (.020-.048)

⓪ — Push fit with light thumb pressure.

### CYLINDERS

**Removal** — Remove engine and remove cylinder head.  
**NOTE** — Mark cylinders to insure they are reinstalled in original position. Remove deflector plates from bottom of cylinders and pull cylinders from pistons.

**Installation** — 1) Check seating surfaces of cylinders on both ends. Make sure seating areas are perfectly clean and true before installing cylinders. Stagger ring gaps 90° apart so that oil ring gap faces upward when cylinder is installed.

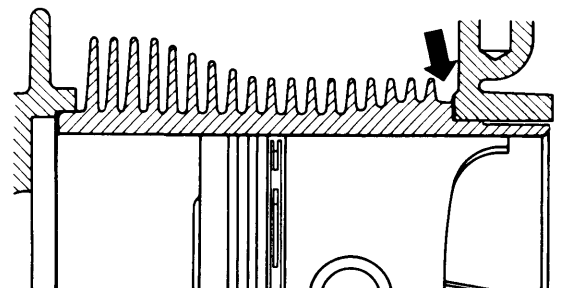

Fig. 4 Location and Seating of Cylinder Seal

2) Apply oil to cylinder, piston, rings and piston pin. Compress rings with suitable ring compressor (VW123). Install new sealing gasket on crankcase side and slide cylinder over piston.

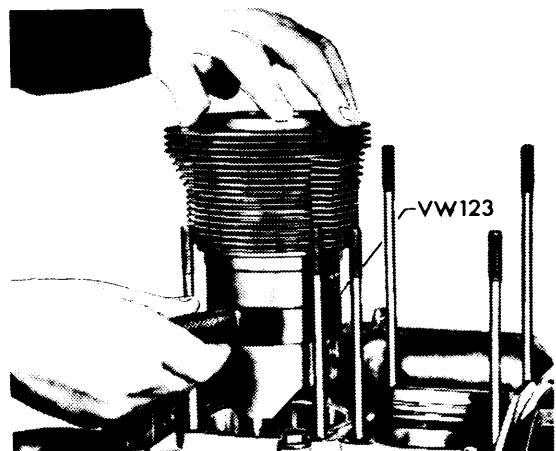

Fig. 5 Installing Cylinder Assembly into Case

3) Make sure studs do not contact cooling fins when cylinder is completely seated against crankcase. Install cylinder deflector plates and remaining components in reverse of removal.

## TYPE 2 1800 CC 4 CYLINDER (Cont.)

### FITTING PISTONS

1) With piston and cylinder removed, measure clearance between piston and cylinder. Check piston size at bottom of skirt and 90° to piston pin. Check cylinder size at several points throughout cylinder, using largest reading to determine clearance.

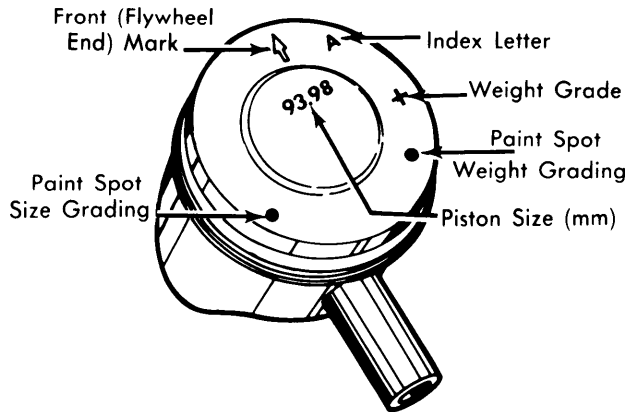

Fig. 6 Top View of Piston with Detail of Piston Markings

2) If clearance exceeds .008" (.20 mm), replace piston and cylinder as a set. New piston must be of same weight grade as original or within 10 g of original piston weight. Piston size, weight and installation position are marked on top of piston (Fig. 6).

Standard Size & Code	Cylinders	Pistons
3.54"		
Blue	3.5429-3.5433"	3.5413"
Pink	3.5433-3.5437"	3.5417"
Green	3.5437-3.5441"	3.5421"
3.56"		
Blue	3.5626-3.5630"	3.5610"
Pink	3.5630-3.5633"	3.5614"
Green	3.5634-3.5638"	3.5618"
3.58"		
Blue	3.5823-3.5826"	3.5807"
Pink	3.5827-3.5830"	3.5811"
Green	3.5831-3.5835"	3.5815"

**NOTE** — Piston alone may be replaced with one of matching size. Only pistons of same size and weight grade should be installed in same engine.



Fig. 7 Using a Feeler Gauge to Measure Piston Ring Gap

3) New piston rings are size graded to match piston-cylinder sets. Measure ring gap with ring installed approximately 1/4" from bottom of cylinder.

4) Install rings on piston and measure ring side clearance using a feeler gauge. If clearance exceeds .005" (.13 mm), on top ring or .004" (.10 mm) on second or oil ring, piston must be replaced.

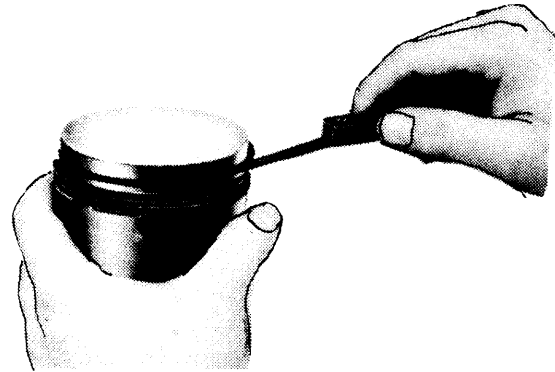

Fig. 8 Measuring Piston Ring Side Clearance with Feeler Gauge

### PISTON PINS

**Removal** — Remove cylinders and mark pistons before removing for proper installation. Using suitable pliers (VW122b), remove piston pin circlips and push piston pin out of piston.

**Installation** — 1) Check fit of pin in piston. Piston pin should be light push fit with piston at 68-167°F. If pin is too loose, both pin and piston must be replaced. Check clearance of pin in rod. If clearance exceeds .0016" (.041 mm), replace piston pin and rod bushing. See *Piston Pin Bushing Replacement*.

2) Install one circlip in piston on side facing flywheel. Position piston on connecting rod and push piston pin through piston. Replace remaining circlip. **NOTE** — Piston may be heated to ease pin installation. Replace remaining components in reverse of removal.

### PISTON PIN BUSHING REPLACEMENT

1) At normal temperature, piston pin should push fit in connecting rod. If side clearance is felt with a new pin installed, bushing must be replaced and reamed to correct fit with a new piston pin.

2) Press bushing out using a suitable mandrel and components (VW402, 409, 421 and 416B). Install new bushing using same procedure and tools as used for removal.

3) Drill through oil holes in connecting rod. Ream bushing to .9455-.9458" (24.016-24.023 mm) with a reamer. Bushing should be free of chatter marks when reaming is completed. Piston pin should push fit into bushing without oil.

## TYPE 2 1800 CC 4 CYLINDER (Cont.)

CRANKSHAFT MAIN & CONNECTING ROD BEARINGS							
Engine	MAIN BEARINGS				CONNECTING ROD BEARINGS		
	Journal Diam. In. (mm)	Clearance In. (mm)	Thrust Bearing	Crankshaft End Play In. (mm)	Journal Diam. In. (mm)	Clearance In. (mm)	Side Play In. (mm)
All No. 1	2.3609-2.3617 (59.967-59.987)	.0016-.0039 (.041-.099)	No. 1	.0027-.0050 (.069-.127)	2.1644-1.1653 (54.975-54.997)	.0008-.0027 (.020-.069)	.004-.016 (.10-.41)
2	2.3609-2.3617 (59.967-59.987)	.0012-.0035 (.030-.089)					
3	2.3609-2.3617 (59.967-59.987)	.0016-.0039 (.041-.099)					
4	1.5739-1.5758 (39.977-40.025)	.0020-.0039 (.051-.099)					

## CRANKCASE

Crankcase must be taken apart to replace connecting rods, connecting rod bearings and main bearings. It is also necessary to disassemble crankcase to remove crankshaft, camshaft, and camshaft bearings.

**Disassembly** — 1) Remove engine from vehicle and remove cylinder heads, cylinders, and pistons. Remove flywheel or drive plate, and crankshaft pulley. Remove distributor, distributor drive shaft and fuel pump.

2) Remove oil cooler, oil filter and bracket, and oil pump assembly. See *Oil Pump Removal*. Remove rear engine carrier crossmember, bonded rubber mountings, and fan hub. Remove oil pan and oil filler pipe mounting bracket bolt.

3) Remove six 10 mm nuts and five 8 mm bolts and nuts. Using spring clips, clamp tappets in right hand crankcase half and lift off right hand crankcase half. **CAUTION** — *Never use sharp tool to pry crankcase halves apart. Smallest scratches will cause oil leak. Use rubber hammer to loosen crankcase halves.*

**Assembly** — 1) Thoroughly clean and inspect both crankcase halves. Remove old sealing compound from mating surfaces and from all bolts, studs and washers. Blow out oil passages with compressed air. Check studs for tightness and check oil suction pipe for tightness.

2) Install crankshaft with connecting rods, in left side crankcase half, making sure dowel pins are properly seated in bearings. Install camshaft. See *Camshaft Installation*. Install camshaft plug using liquid sealer all around plug. Spread liquid sealer over mating surfaces of crankcase halves.

3) Using spring clips, clamp tappets in right hand half of crankcase and join crankcase halves. Coat main bearing bolt heads (10 mm) with sealer and install in crankcase. **NOTE** — *Install plastic dampers (part No. 021 101 107) on shank of main bearing bolts whether or not originally equipped.*

4) Coat the sealing nuts for main bearing bolts with sealer and install nuts with sealing rings outward. Tighten main bearing nuts and bolts and hand turn crankshaft to check for free movement. Coat bolt heads and nuts of 8 mm bolts with sealer, then install and tighten.

5) Check crankshaft end play. See *Thrust Bearing Alignment*. Install new crankshaft oil seals. See *Front Crankshaft Oil Seal Replacement and Rear Crankshaft Oil Seal Replacement*. Install remaining components in reverse of removal procedure.

## MAIN &amp; CONNECTING ROD BEARING SERVICE

1) With crankshaft and connecting rod assembly removed, remove snap ring securing distributor drive gear and crankshaft gear to crankshaft. Remove distributor drive gear and crankshaft gear by pressing or using a suitable mandrel (VW457). Remove number three bearing. Remove connecting rods.

2) Thoroughly clean and inspect crankshaft. Blow out oil passages with compressed air. Check runout of crankshaft, if runout is more than .0008" (.020 mm), regrind crankshaft to next undersize.

3) Check crankshaft journals for wear, if journals are worn more than .0012" (.030 mm), regrind crankshaft to next undersize. Main and connecting rod bearings are available in .010", .020" and .030" undersize.

4) Lubricate and install number three bearing. Heat crankshaft to approximately 176°F in an oil bath and install crankshaft and distributor drive gears using suitable drivers (VW427, VW428 and VW415a). Install snap ring.

5) Thoroughly clean and inspect connecting rods for damage. Replace connecting rod if studs are damaged. Using plastigage method, check connecting rod bearing clearance. If clearance exceeds .006" (.15 mm), replace bearings. Check piston fit in connecting rod, if fit is too loose, replace pin bushing. See *Piston Pin Installation*.

6) Install bearing halves in connecting rod and cap. Install on crankshaft with numbers on rod and cap on same side. Forged mark on connecting rod must face up when crankshaft is installed. Install and tighten rod cap nuts.

7) Check connecting rod side play with feeler gauge. If side play exceeds .026" (.66 mm), replace connecting rod. Install crankshaft and connecting rod assembly as previously outlined. Check crankshaft end play. See *Thrust Bearing Alignment*.

## TYPE 2 1800 CC 4 CYLINDER (Cont.)

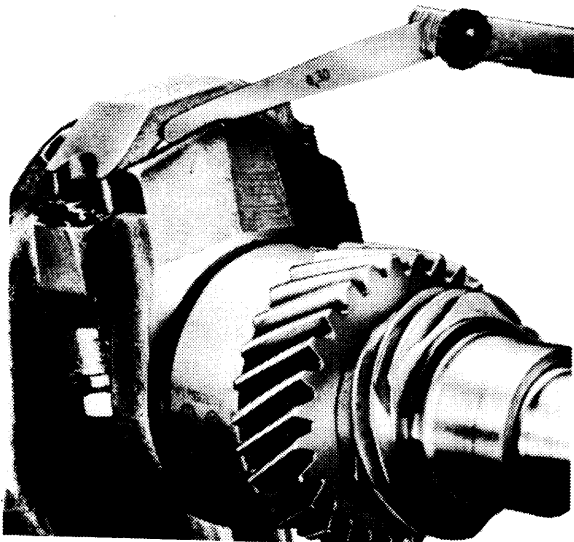

Fig. 9 Using a Feeler Gauge to Check Connecting Rod Side Clearance

### THRUST BEARING ALIGNMENT

**NOTE** — Crankshaft end play is checked with engine assembled.

1) Install flywheel with two shims, but do not install crankshaft oil seal. Attach dial indicator to crankcase and measure back and forth movement of crankshaft.

2) Calculate necessary thickness of third shim. Install third shim and recheck end play. Thickness of shim is etched on face of shim, always use three shims to obtain correct end play.

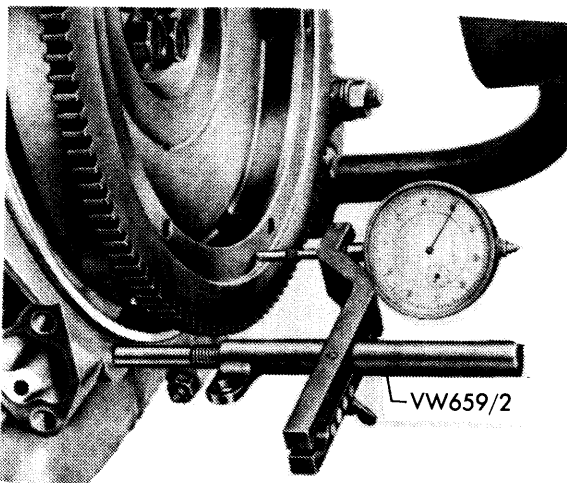

Fig. 10 Using a Dial Indicator to Check Crankshaft End Play

### Thrust Bearing Shims

MM Markings On Shim	Inch Equivalent
.24 mm .....	.0094"
.30 mm .....	.0118"
.32 mm .....	.0126"
.34 mm .....	.0134"
.36 mm .....	.0142"
.38 mm .....	.0150"

3) With correct shim thickness determined, install crankshaft oil seal. See *Front Crankshaft Oil Seal*. Install flywheel, tighten bolts as required, and recheck crankshaft end play.

### FRONT CRANKSHAFT OIL SEAL

1) Remove flywheel and pry out crankshaft oil seal. Make sure seal seat in crankcase is clean. If necessary, chamfer edges of seal seat.

2) Press seal into crankcase, using a suitable seal installer (VW191). Make sure seal is seated in bottom of crankcase. Lubricate sealing edge of seal, install flywheel, and tighten bolts.

### REAR CRANKSHAFT OIL SEAL

1) Remove cooling blower impeller from rear of engine. Remove impeller hub, using a suitable puller (VW185).

2) Pry out old seal and thoroughly clean seal seat in crankcase. Chamfer edges of seal seat, if necessary. Press new seal into crankcase, using a suitable seal installer (VW190). Make sure seal is seated in bottom of crankcase. Lubricate sealing edge of seal and install cooling blower impeller.

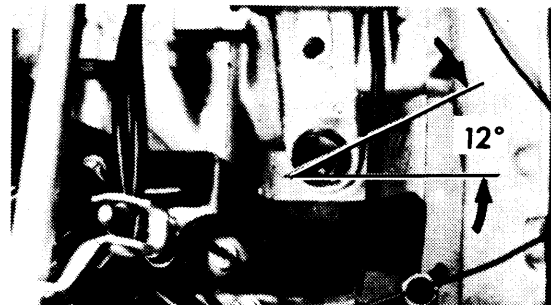

Fig. 11 1800 cc Engine Distributor Drive Installation Position

### DISTRIBUTOR DRIVE INSTALLATION

When crankcase has been assembled, and remaining components installed, distributor drive must be installed in correct position. Rotate crankshaft until number one piston is at TDC of compression stroke. Install distributor drive with slot at a 12° angle to center line of engine with small segment of slot toward outside of vehicle (Fig. 11).

CAMSHAFT			
Engine	Journal Diam. In. (mm)	Clearance In. (mm)	Lobe Lift In. (mm)
All	.9839-.9843 (24.991-25.001)	.0008-.0020 (.020-.051)	.....

### CAMSHAFT INSTALLATION

1) With camshaft removed, check riveting of camshaft gear to camshaft. Check camshaft for runout, if runout exceeds .0016" (.041 mm), replace camshaft.

## TYPE 2 1800 CC 4 CYLINDER (Cont.)

2) Check gear backlash with camshaft and crankshaft installed in crankcase half. Correct backlash is .002" (.05 mm). Gears have correct fit when crankshaft is rotated backwards and camshaft does not try to lift out of bearings.

3) If camshaft rises out of bearings, teeth on camshaft gear have the wrong pitch radius for crankshaft gear. Camshafts with gears that have various pitch radii are available. Pitch radius is stamped on back of gear facing number three bearing journal of camshaft.

4) Install camshaft with "O" stamped in tooth on outside of camshaft gear between two teeth with punch marks on crankshaft gear. Assemble crankcase halves as previously outlined.

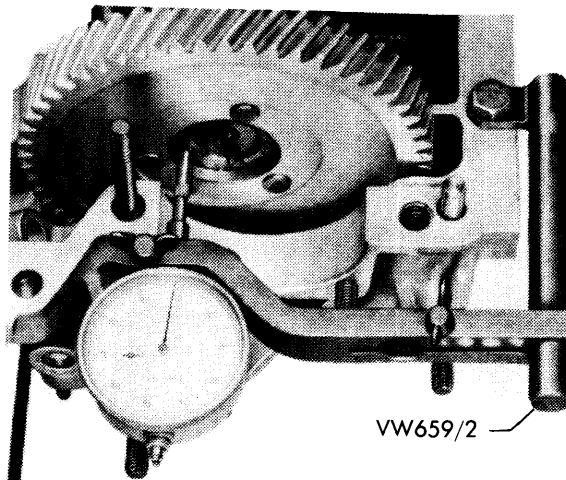

Fig. 12 Measuring Camshaft End Play with a Dial Gauge

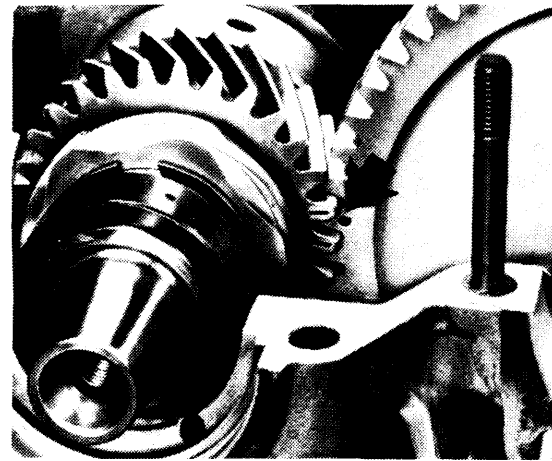

Fig. 13 Position of Camshaft Timing Gear

## ENGINE OILING

**Oil Capacity** — 3.15 qts. Add .5 qt. with filter change.

**Oil Pressure** — 42 psi at 2500 RPM with engine at 158°F.

**Oil Filter** — Full flow oil filter.

**Pressure Regulator Valves** — Oil pressure relief valve, used to protect oil cooler from excessive pressure, is located in crankcase under oil filter. Oil pressure control valve, used to control oil pressure to bearings, is located in crankcase below oil breather. Oil pressure relief spring should have length of 1.563" at 15-19.5 lbs. load. Oil pressure control spring should have length of 1.062" at 3.8-4.4 lbs. load.

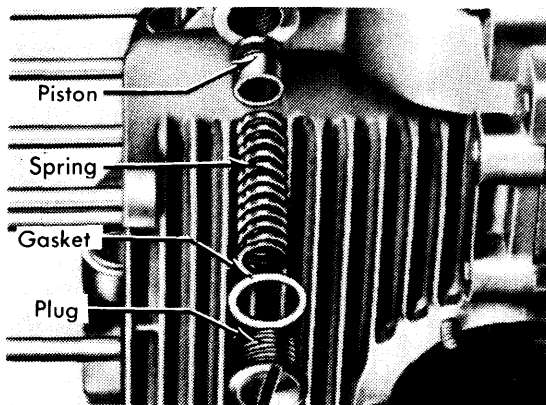

Fig. 14 Expanded View of Relief Valve Components

## ENGINE OILING SYSTEM

Full pressure lubrication system utilizing a gear type oil pump installed in rear of engine and driven by the camshaft. Oil is pumped through oil filter, oil cooler and into main oil passages in crankcase. Crankshaft main and connecting rod journals are oiled through crossdrilled oil passages in crankcase. Oil is pumped to camshaft through oil passages that also lubricate

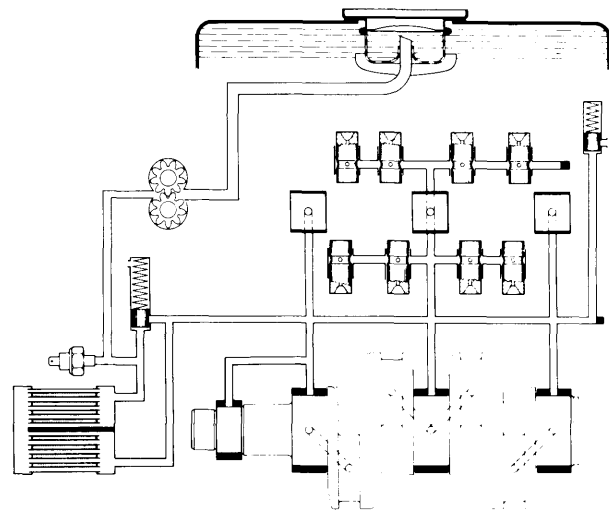

Fig. 15 Distribution of Oil for Engine Lubrication

## TYPE 2 1800 CC 4 CYLINDER (Cont.)

valve tappets. Oil flows through push rods to lubricate rocker arms and shafts. Valve stems are lubricated by splash oil from rocker arms. Excess oil flows back into crankcase through push rod tubes. Cylinder walls and piston pins are lubricated by splash oil.

### OIL COOLER

To remove oil cooler, remove cooling air fan housing, three 6 mm nuts with washers attaching oil cooler to rear of crankcase, and bolts attaching oil cooler support strap. Remove support strap and oil cooler as unit. Always use new rubber seals when installing oil cooler.

### OIL PUMP

1) Cooling shrouds, blower impeller and related components must be removed from rear of engine to remove oil pump. See *Engine Cooling*. Remove nuts securing oil pump to crankcase and pry pump out of crankcase, prying equally on both sides.

2) With pump removed, remove four nuts from pump cover and remove cover with a suitable puller (VW803). Pull out drive gear and driven gear. Thoroughly clean and inspect all components for signs of wear or damage and replace as necessary.

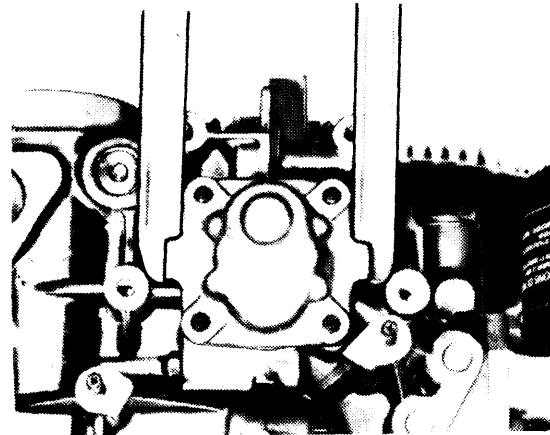

Fig. 16 Using Special Puller to Remove Oil Pump

3) To assemble, lubricate drive gear and driven gear and insert in oil pump housing. Install oil pump cover with new sealing ring lubricated and installed in housing. Tighten nuts and check rotation of gears.

4) To install oil pump, insert a new seal in crankcase. Position drive gear shaft so drive portion of shaft is aligned with slot in camshaft and install oil pump in crankcase. Rotate crankshaft two revolutions to center oil pump and tighten nuts.

## ENGINE COOLING

**Thermostat** – Opens at 150-160°F (65.6-71.1°C).

**Cooling Volume** – 1699 CFM @ 4600 RPM.

### COOLING SYSTEM

Engine is cooled by a radial blower mounted to rear end of crankshaft. Blower draws air through opening in blower shroud at rear of engine. Blower shroud is two-piece unit, mounted around blower and attached to crankcase. As air is drawn in, it is directed over finned cylinders and cylinder heads by deflector plates. A thermostat is mounted under No. 1 and No. 2 cylinders and actuates flaps mounted in shroud to control volume of air directed in deflector plates. As engine warms up, thermostat opens flaps completely to allow total flow of air.

### BLOWER SHROUD REMOVAL

1) Remove engine as previously outlined. Remove air injection pump, belt, and adjusting bracket. Remove extension shaft with pulley, ignition timing scale, fan with crankshaft pulley and alternator belt.

2) Disconnect cooling air control cable from control flap shaft. Pull rubber elbow for alternator out of front half of blower shroud. Remove four nuts attaching blower shroud to crankcase and pull assembly to rear and off engine. To install, reverse removal procedure. Adjust air flap control cable by pushing flaps into closed position and tighten cable.

3) Disconnect flap actuating cable from control shaft. Remove nuts securing shroud to crankcase and remove both halves of blower shroud.

4) To install, reverse removal procedure. Adjust air flap control by pushing flaps into closed position and tighten cable control. Attach elbow for cooling alternator to fan shroud front half.

5) Install drive belt and tighten alternator into proper belt tensioning position (maximum 0.6" deflection). Install cover plates and engine as previously outlined.

### TIGHTENING SPECIFICATIONS

Application	Ft. Lbs. (mkg)
Connecting Rod Nut.....	24 (3.32)
Crankcase Half Nuts (8 mm) .....	14 (1.94)
Crankcase Half Sealing Nuts (10 mm).....	25 (3.46)
Cylinder Head Nuts .....	23 (3.18)
Rocker Shaft-to-Cylinder Head .....	10 (1.38)
Heat Exchanger-to-Cylinder Head .....	16 (2.21)
Oil Pan-to-Crankcase Nuts.....	9 (1.24)
Drive Plate-to-Crankshaft .....	65 (8.99)
Hub-to-Crankshaft Bolt.....	23 (3.18)
Fan-to-Hub .....	14 (1.94)
Extension Shaft & Pulley-to-Fan.....	14 (1.94)
Engine-to-Transmission .....	22 (3.04)
Oil Pump-to-Crankcase .....	14 (1.94)
Oil Cooler-to-Crankcase .....	14 (1.94)
Flywheel-to-Crankshaft.....	80 (11.06)
Clutch-to-Flywheel .....	18 (2.49)
Torque Converter-to-Driveplate .....	14 (1.94)