

## DASHER 4 CYLINDER

### GENERAL SPECIFICATIONS

Year	Displ.		Carburetor	HP at RPM	Torque (Ft. Lbs. at RPM)	Compr. Ratio	Bore		Stroke	
	cu. ins.	cc					in.	mm	in.	mm
1975	89.7	1470	2-Bbl.	71@5800	75@5800	8.5:1	3.01	76.5	3.15	80

### ENGINE IDENTIFICATION

Engine identification number is stamped on left side of engine block, near fuel pump. Code numbers indicate the following:

#### Engine Codes

Application	Code
Manual Transmission Models .....	XS
Automatic Transmission Models .....	XR

### ENGINE REMOVAL

- 1) Disconnect battery ground strap. Pull off preheater hose and oil breather hose, remove cover, and unscrew nut from mounting bolt inside air filter. Remove air cleaner assembly.
- 2) Remove accelerator cable after pulling off retaining clip. Loosen upper adjustment nut and detach clutch cable. Disconnect and plug fuel hose. On relay plate with fuse box, loosen screws and bend harness clip open. Remove heater control cable after extracting clip.
- 3) Remove front engine mount, then front engine mount support. Disconnect electrical wiring from the following: ignition coil, oil pressure switch, ignition distributor, coolant temperature switch, by-pass air cut-off valve, generator, radiator thermo switch, and fan motor.
- 4) Remove engine block plug and lower radiator hose, then drain cooling system. Remove all coolant hoses. Remove heater valve operating cable by loosening clamps, pulling off valve hoses, detaching clip of Bowden cable, and unhooking cable at valve.
- 5) Loosen air duct attachments and all radiator mounting bolts, then lift out radiator. Raise vehicle on hoist. Remove starter. Unscrew exhaust pipe-to-manifold retaining nuts. Remove nuts from both engine mountings on left and right side.
- 6) Unscrew and remove lower engine-transmission bolts, and only loosen upper bolts. If vehicle is equipped with automatic

transmission, remove torque converter bolts. Support transmission with a suitable jack (VW 785/1).

- 7) Lower vehicle to ground. Attach engine lifting device and raise assembly until transmission housing contacts steering drive. Adjust transmission support to retain this position. Remove upper engine-transmission retaining bolts, then pry engine and transmission apart at mounting joint and remove intermediate plate from engine. Lift and turn engine diagonally to remove from engine compartment.

### CYLINDER HEAD

- 1) Disconnect battery ground cable. Drain cooling system and disconnect hoses which are attached to cylinder head. Remove exhaust pipe and electrical wiring. Disengage accelerator linkage and disconnect at its holder. Loosen alternator tensioner and remove camshaft drive belt and alternator belt.
- 2) Remove all other components necessary to gain clearance around camshaft cover. Remove cover, Remove the head bolts in reverse order shown in Fig. 1. When installing, ensure head gasket is positioned with "TOP" or "OBEN" mark facing upward. Tighten head bolts to "cold" setting using Fig. 1 for tightening sequence reference.

*NOTE* — When checking cylinder head bolts or retorquing bolts, either cold or hot setting can be used.

#### Cylinder Head Tightening

Application	Ft. Lbs. (mkg)
Cold .....	54 (7.5)
Hot .....	61 (8.5)

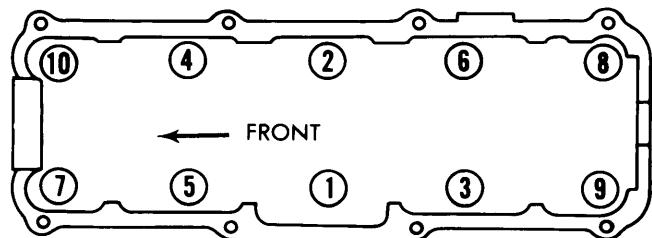

Fig. 1 Cylinder Head Tightening Sequence

### VALVES

Engine & Valve	Head Diam. In. (mm)	Face Angle	Seat Angle	Seat Width In. (mm)	Stem Diameter In. (mm)	Stem Clearance In. (mm)	Valve Lift In. (mm)
1470 cc Intake	1.338 (33.9)	45°	45°	.079 (2.0)	.314 (7.98)	.001-.002 (.03-.05)	....
Exhaust	1.220 (31.0)	45°	45°	.095 (2.4)	.313 (7.95)	.002-.003 (.05-.07)	....

## DASHER 4 CYLINDER

## VALVE ARRANGEMENT

E-I-E-I-I-E-I-E (front to rear).

## VALVE GUIDE SERVICING

1) Before taking measurements, clean valve guides with a cleaning broach. To measure, attach a suitable device with a dial gauge (VW689/1) to mounting surface of cylinder head. Insert a new valve until end of stem is flush with end of valve guide. Rock valve head against dial indicator and check amount of "rock" recorded. Maximum allowable rock is .016" (1.0 mm) for intake valves, and .051" (1.3 mm) for exhaust valves. Proper valve guide diameter is .315-.316" (8.01-1.04 mm).

2) Use a suitable press and adapter (10-206) to remove and install valve guides. Always perform this operation from top side of head. When installing new guides, heat cylinder head in oil bath to approximately 176-212°F (80-100°C), and press in new guide until it measures 2.23" (56.6 mm) from top of guide to cylinder head gasket mounting surface. Ream guide to proper size, reface valve seat, and rework valve.

## VALVE STEM OIL SEALS

With tappet, adjuster pad, keepers, springs, and spring seats removed, extract valve stem oil seal. When installing new seal, first position protective plastic sleeve on valve stem, lubricate seal, and use a suitable mandrel (10-204) to push seal onto valve guide.

remove valve keepers and collars. Lift out valve springs and extract lower spring seats. Check spring length and tension, and examine condition of all other spring parts. To install, reverse removal procedure.

## VALVE CLEARANCE ADJUSTMENT

1) Adjust valves with engine at normal operating temperature. Clearance adjustments are to be checked and made according to firing order sequence (1-3-4-2). Rotate crankshaft until No. 4 cylinder valves overlap, then measure valve clearances of No. 1 cylinder.

2) If adjustment is necessary, determine thickness of tappet adjuster disc installed. Using clearance measurement, determine thickness of tappet disc necessary to bring valve clearances within specifications. Tappet discs are available in .0019" (.05 mm) increments from .1181" (3.0 mm) to .1673" (4.25 mm). Thickness is stamped on bottom side of disc.

3) Special tools 10-208 (disc removal tool) and VW546 (tappet depressing tool) are required to remove and install new tappet discs. Rotate camshaft until cams of cylinder to be changed no longer rest on the tappet discs. Turn tappet until notches are at 90° to camshaft. Install tool VW546 and depress tappet. Using tool 10-208, grasp tappet disc and rotate it out from under camshaft. Install proper disc and remove tools. Repeat procedure as required to bring all valves within proper clearances.

VALVE SPRINGS			
Engine	Free Length In. (mm)	PRESSURE Lbs. @ In. (kg @ mm)	
		Valve Closed	Valve Open
1470 cc			
Inner	....	46-51@.719 (21-23@18.3)	....
Outer	....	96-106@.916 (43.5-48@22.3)	....

## VALVE SPRINGS

With tappets and adjuster pads removed, install suitable valve spring compressor tool (10-210). Compress springs and

## Valve Clearance Specifications

Application	In. (mm)
Intake	
Hot .....	.008-.012 (.20-.30)
Cold .....	.006-.010 (.15-.25)
Exhaust	
Hot .....	.016-.020 (.40-.50)
Cold .....	.014-.018 (.35-.45)

NOTE - Cold settings are given for reference as initial settings to be used during cylinder head rework. Final adjustments are to be made with engine at normal operating temperature. After head repairs, recheck valve clearances after 600 miles.

PISTONS, PINS, RINGS						
Engine	PISTONS		PINS		RINGS	
	Clearance In. (mm)	Piston Fit In. (mm)	Rod Fit In. (mm)	Rings	End Gap In. (mm)	Side Clearance In. (mm)
1470 cc	.0012 (.03)	Push Fit	Push Fit	Comp.	.012-.018 (.30-.45)	.0008-.002 (.02-.05)
				Oil	.010-.016 (.25-.40)	.0008-.002 (.02-.05)

## OIL PAN

Using suitable device to support engine from above, drain engine oil, then unbolt and remove subframe. If necessary, remove flywheel guard plate. Unbolt and remove oil pan.

## PISTON &amp; ROD ASSEMBLY

1) Before removing connecting rods, mark rod and cap for proper reinstallation. Remove rod cap bolts and carefully push piston and rod assembly out top of cylinder.

## DASHER 4 CYLINDER

2) On reassembly, ensure cast bosses and locating projections of bearing inserts face toward intermediate shaft. All connecting rods must be of same weight class (weight is stamped on bottom of rod caps). Using a suitable ring compressor, install piston and rod assemblies with arrow on crown of piston facing forward.

### FITTING PISTONS

1) Measure cylinder at three points: .39" (10 mm) from top and bottom, and at center of bore. Take measurements in line with thrust face and also at 90° to thrust face. Cylinder wear limit is .0028" (.07 mm) beyond standard dimensions; if this is exceeded, rebore cylinder and install oversize pistons.

2) Measure pistons at .63" (16 mm) from bottom of piston skirt (measuring 90° to pin bore). Combining this measurement with measurement of corresponding cylinder bore, note piston-to-cylinder clearance. If this exceeds .0028" (.07 mm), oversize pistons must be installed.

3) Place piston rings squarely in top of cylinder bore (above ring ridge) and measure end gap. Measure ring side clearance. Install rings on piston with end gaps 120° offset to each other (start with oil ring gap directly to the rear). Ensure stamp mark "TOP" on rings is facing upward.

*NOTE* — Engine blocks are stamp-coded on left front side (just below head) with a number which corresponds to size of piston and bore.

### Standard Pistons & Cylinder Dia.

Piston Dia. In. (mm)	Cyl. Dia. In. (mm)	Stamp Code
3.0110 (76.48)	3.0121 (76.51)	651
3.0114 (76.49)	3.0125 (76.52)	652
3.0118 (76.50)	3.0129 (76.53)	653

### Oversize Pistons & Cylinder Dia.

Piston Dia. In. (mm)	Cyl. Dia. In. (mm)	Stamp Code
3.0208 (76.73)	3.0220 (76.76)	676
3.0212 (76.74)	3.0224 (76.77)	677
3.0216 (76.75)	3.0228 (76.78)	678
3.0307 (76.98)	3.0318 (77.01)	701
3.0310 (76.99)	3.0322 (77.02)	702
3.0314 (77.00)	3.0326 (77.03)	703
3.0503 (77.48)	3.0516 (77.51)	751
3.0507 (77.49)	3.0520 (77.52)	752
3.0511 (77.50)	3.0524 (77.53)	753

### PISTON PINS

Use a suitable drift to remove circlip from piston. Insert suitable piston pin removal tool (VW207c) and withdraw pin. To install, use same tool, and replace circlips. Ensure piston is attached to connecting rod so that arrow will be facing forward when placed in cylinder.

CRANKSHAFT MAIN & CONNECTING ROD BEARINGS							
Engine	MAIN BEARINGS				CONNECTING ROD BEARINGS		
	Journal Diam. In. (mm)	Clearance In. (mm)	Thrust Bearing	Crankshaft End Play In. (mm)	Journal Diam. In. (mm)	Clearance In. (mm)	Side Play In. (mm)
1470 cc	2.126 (54)	.0011-.0033 (.028-.088)	No. 3	.003-.007 (.07-.17)	1.81 (46)	⊕.005 (.12)	⊕.015 (.37)

⊕ — Wear Limit.

### MAIN & CONNECTING ROD BEARINGS

1) Push crankshaft toward one end and measure crankshaft end play at No. 3 (thrust) bearing. Main bearing caps are stamped "1" to "5" (front to rear), and must be returned to original positions upon reassembly. Measure end play (side play) of connecting rods. Remove all bearing caps and check bearing clearance using Plastigage method.

2) Measure crankshaft journals with a micrometer to determine if crankshaft is out-of-round. Maximum ovality permissible is .0012" (.03 mm). Install main inserts with bearing half having oil groove into block. Lubricate bearings and install caps.

#### Crankshaft Journal Diameters

Size	Main Bearing In. (mm)	Con. Rod Bearing In. (mm)
Standard	2.126 (54.00)	1.81 (46.00)
1st US	2.116 (53.75)	1.80 (45.75)
2nd US	2.106 (53.50)	1.79 (45.50)
3rd US	2.096 (53.25)	1.78 (45.25)

### REAR MAIN BEARING OIL SEAL

Rear main bearing oil seal may be replaced with engine in vehicle, if transmission and flywheel are removed. Carefully pry oil seal from crankcase. Install protective sleeve tool (10-205) on crankshaft. Slide new seal over tool, by hand, as far as possible, then remove tool. Attach suitable pressing tool (10-220) and press seal into final position by alternating tightening tool attaching bolts (see illustration).

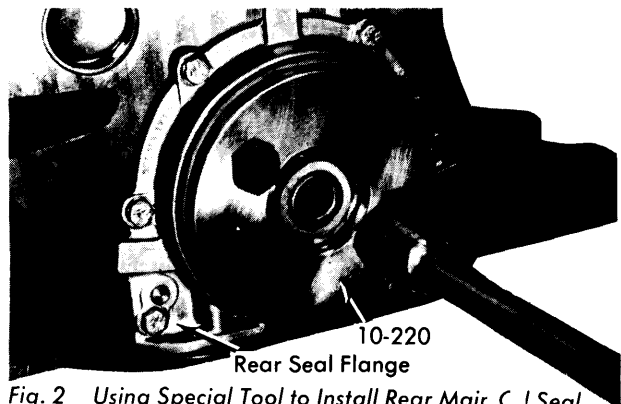

Fig. 2 Using Special Tool to Install Rear Main C I Seal

## DASHER 4 CYLINDER

## INTERMEDIATE SHAFT OIL SEAL

Remove seal flange from engine block, and use a suitable press and mandrel to remove and install new oil seal.

## FRONT MAIN BEARING OIL SEAL

1) Front main bearing oil seal may be replaced with engine in vehicle: remove license plate, radiator grille, and camshaft belt guard. Rotate crankshaft to TDC and use a screwdriver to lock crankshaft from turning (through opening in transmission case). Remove pulley bolt. Loosen camshaft belt tensioner and alternator adjuster. Remove both belts.

2) Pry seal out of flange using suitable removal tool (10-219). Do not place tool between seal and crankshaft, but position on inner edge of support ring by cutting seal dust lip with sharp edge of tool (see illustration). To install new seal, use suitable installation tool (10-203), placing seal over guide sleeve of tool. Press seal in until flush with flange, by turning tool bolt.

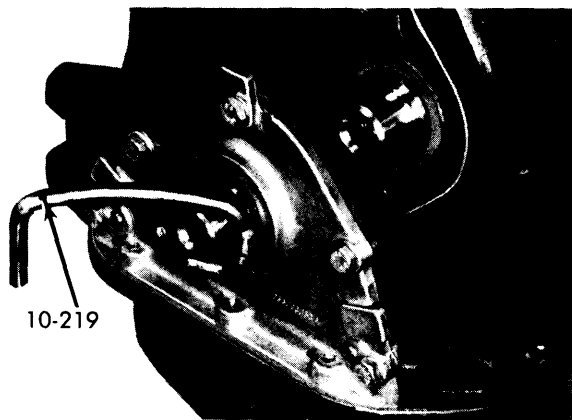

Fig. 3 Using Special Tool 10-21 to Remove Front Main Oil Seal

## CAMSHAFT

Engine	Journal Diam. In. (mm)	Clearance In. (mm)ⓐ	Lobe Lift In. (mm)
1470 cc	.....	.0015-.0024 (.04-.06)	.....

ⓐ — End play .006" (.15 mm)

## TIMING BELT

1) Loosen alternator mounting bolts and remove alternator belt. Unbolt and remove camshaft belt cover. Loosen mounting nut of camshaft belt tensioner arm and remove tension from belt. Slide belt forward off camshaft sprocket. **NOTE** — Do not remove camshaft belt sprocket. See Valve Timing for proper location of timing marks before replacing belt.

2) Install new belt and adjust tensioner eccentric until it is just possible to twist timing belt 90° with thumb and forefinger pressure applied at midpoint between components, then adjust alternator belt tension until it is possible to depress belt .40-.50" (10-15 mm) at midpoint on longest run of belt.

## CAMSHAFT

With camshaft cover removed, loosen and remove bearing caps in the following sequence: (caps are numbered front to rear) 5, 1, and 3, then loosen nuts of bearings caps 2 and 4 diagonally. Use same sequence for installation after lubricating all bearing contact surfaces. Ensure caps are replaced in their same respective positions as removed.

Engine	VALVE TIMING			
	INTAKE		EXHAUST	
	Open (BTDC)	Close (ALDC)	Open (BLDC)	Close (ATDC)
1470 cc	7°	43°	47°	3°

## VALVE TIMING

With timing belt removed as previously described, turn crankshaft and intermediate shaft until both markings are in line with notch of pulley (Fig. 4) this is firing point of No. 1 cylinder. Next, turn camshaft until marking on rear of camshaft sprocket is in line with cylinder head cover. (Fig. 5). Replace timing belt.

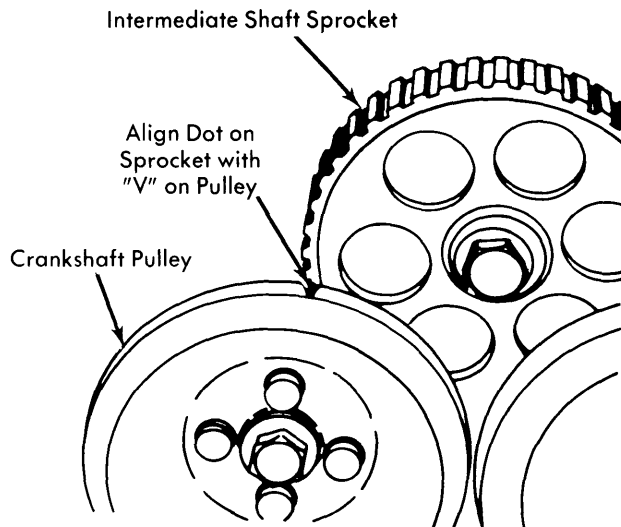

Fig. 4 Crankshaft and Intermediate Shaft Index Marks Aligned with Notch on Pulley

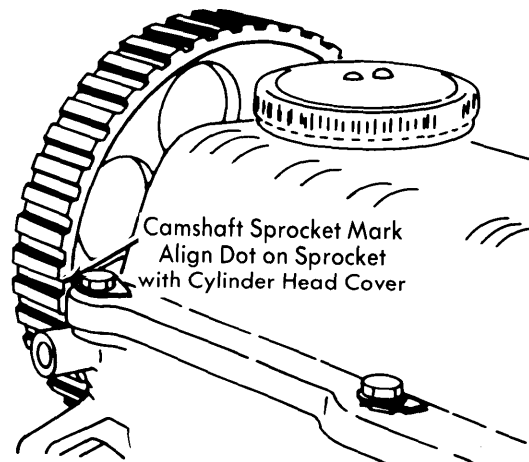

Fig. 5 Index Mark on Camshaft Sprocket Aligned with Cylinder Head Cover

## DASHER 4 CYLINDER

### ENGINE OILING

**Crankcase Capacity** — 3.7 qts. (incl. filter).

**Oil Filter** — Replaceable spin-on type.

**Normal Oil Pressure** — 28 psi@2000 RPM (normal operating temperature).

### ENGINE OILING SYSTEM

Oiling system is a pressure feed type. A gear oil pump lifts oil from pan and pressure feeds it to crankshaft journals,

camshaft bearings, and intermediate shaft. Other parts of system receive oil mist or splash for lubrication.

### OIL PUMP

Remove oil pan, as previously described. Unscrew two oil pump mounting bolts and pull pump straight down from engine. Unbolt pump cover, withdraw pump drive shaft and gears, then bend up metal edges and remove filter and screen. Clean and assemble all parts then check gear-to-gear backlash; it should be .002-.008" (.05-.20 mm). Lay a straightedge across pump face and insert a feeler gauge to determine gear-to-cover end play; it should be .006" (.15 mm).

### ENGINE COOLING

**Cooling System Capacity** — 12.7 pints.

**Thermostat** — Begins to open at 176°F (80°C).

**Radiator Cap** — Pressure cap relieves between 13-16 psi (approximate).

### WATER PUMP

Drain cooling system and remove alternator belt. Unbolt and remove camshaft belt cover. Unscrew water pump mounting bolts and lift out pump by turning slightly. Remove pulley and pump body mounting screws. Remove pump housing. Check for wear. To assemble, reverse procedure. Adjust belt tension.

### TIGHTENING SPECIFICATIONS

Application	Ft. Lbs. (mkg)
Timing Belt Tensioner Bolt .....	33 (4.5)
Intermediate Sprocket Bolt .....	58 (8.0)
Crankshaft Pulley Bolt .....	58 (8.0)
Water Pump Pulley Bolts .....	14 (2.0)
Main Bearing Cap Bolts .....	47 (6.5)
Flywheel-to-Crankshaft Bolts .....	54 (7.5)
Connecting Rod Cap Bolts .....	33 (4.5)
Camshaft Sprocket Bolt .....	58 (8.0)
Camshaft Bearing Cap Nuts .....	14 (2.0)
Cylinder Head Bolts	
Cold .....	54 (7.5)
Hot .....	61 (8.5)
Oil Pump Mounting Bolts	
Socket Head Bolt .....	14 (2.0)
Hex Head Bolt .....	7 (1.0)
Oil Pan Bolts .....	7 (1.0)