

Porsche Engines

911 6 CYLINDER

GENERAL SPECIFICATIONS										
Year	Displ.		Carburetor	HP at RPM	Torque (Ft. Lbs. at RPM)	Compr. Ratio	Bore		Stroke	
	cu. ins.	cc					in.	mm	in.	mm
1975	163.97	2687	Fuel Inj.	157@ 5800	166@4000	8.5-1	3.54	90	2.77	70.4

ENGINE IDENTIFICATION

Engine identification number is die stamped on blower fan support near oil temperature sensor. Second digit of number identifies engines as follows:

Application	Engine Code
911 S and Carrera	
Federal.....	4
California.....	5

ENGINE REMOVAL

1) Place vehicle on floor stands and open hood. Disconnect hot air duct from air cleaner. Remove air cleaner and disconnect oil tank vent hose. Disconnect wires from electric fuel pump.

2) Disconnect alternator cables at voltage regulator and body clamps. Disconnect coil lead at coil and fuel line at float chambers. Remove battery cables. Disconnect throttle linkage at bell crank.

3) Remove oil breather hose from oil filler. Disconnect oil pressure sensor wire. Drain engine oil and remove hoses from oil tank.

4) Disconnect axle shafts at shaft flanges. Disconnect power cable from starter. Separate air gates from hot air ducts connecting heat exchanger and air gate.

5) Loosen and withdraw clutch cable at clutch release lever. Disconnect engine ground strap. Remove back-up light wire. Disconnect throttle linkage.

6) Remove rear center tunnel cover in passenger compartment. Remove rubber boot in tunnel by pulling forward. Remove conical bolt. Disconnect shift rod clutch from shift control lever.

7) Using a carrier plate, place jack under engine at center of gravity. Tension jack slightly. Remove engine and transmission mounting bolts. Lower jack and pull engine and transmission rearward. Separate engine and transmission.

CYLINDER HEAD REMOVAL

Removal — 1) With fuel injection system removed, remove distributor cap and spark plug wires. Remove all cool air ducts and cover shrouds.

2) Remove air ducts connecting air blower outlets and heat exchanger inlets, together with cover shrouds. Remove rear engine mount (transverse leaf spring) from holder.

3) Remove fuel pump and hoses. Remove exhaust pipes and engine mounting bracket. Remove blower pulley and drive belt.

4) Loosen both screws of band strap which attaches alternator to blower housing. Pull blower housing rearward. Disconnect alternator cables and remove blower housing with alternator.

5) Remove heat exchanger using suitable wrenches (No. P 205 & P 217). Disconnect camshaft oil lines between crankcase and chain housing covers. Remove covers.

6) Remove chain tensioner, pivot lever and chain sprocket as an assembly. Remove camshaft sprocket nuts using suitable tools (No. P 202 & P 203). Withdraw sprocket dowel pin, using suitable tool (No. P 212).

7) With a screwdriver lift spring retainers from groove and remove chain guides. Remove camshaft sprockets and flanges. Pry Woodruff keys from camshafts.

NOTE — Each cylinder has a separate cylinder head. If camshaft housing is removed, any single head may be removed. If camshaft housing is left attached to cylinder heads, cylinder heads and camshaft housing may be removed as an assembly.

8) To remove a single head, rotate camshaft to take load off of rocker arm shaft to be removed. Loosen rocker arm shafts and push out shafts. Remove camshaft housing.

9) Using a suitable tool (No. P 119), remove cylinder head nuts and lift off cylinder head.

NOTE — Mark cylinder heads, cylinders and camshaft housings so they will be reassembled in their original positions.

10) To remove all three cylinder heads and camshaft housing as an assembly, evenly loosen and unscrew cylinder head nuts using suitable tool (No. P 119).

Installation — 1) Place cylinder head gaskets on cylinders with perforated side of steel insert facing cylinder. Install cylinder heads and oil return tubes at same time. Coat oil return tubes with engine oil for easier installation. Lightly tighten cylinder head nuts.

2) Install cool air shrouds and attach with clamps. Thinly coat camshaft housing gasket with gasket compound. Slide camshaft housing onto mounting studs. Tighten camshaft housing nuts down a few turns to ensure gasket seal. Install Allen screws in proper location and tighten camshaft housing in a crosswise pattern.

911 6 CYLINDER (Cont.)

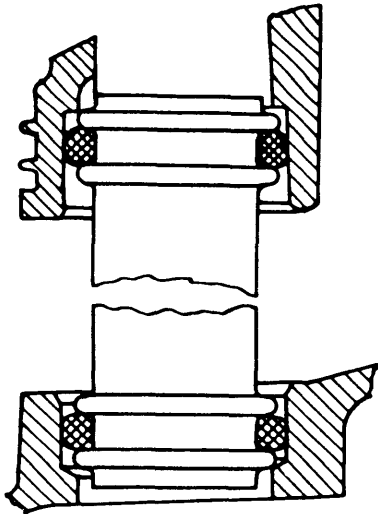

Fig. 1 Cylinder Head Oil Return Tube Installation

NOTE — Camshaft housings are interchangeable, but camshafts are not. Camshafts must be positioned on their proper side, see Fig. 4.

3) Tighten cylinder head nuts in a crosswise pattern, checking that camshaft does not bind in housing. If camshaft binds, loosen cylinder head nuts and tighten in a different sequence. With cylinder head nuts tight, camshaft must be free to rotate.

4) Install rocker arms and shafts. Install rocker arm shaft with approximately .060" (1.52 mm) clearance between shaft grooves and mounting face, see Fig. 2. Tighten Allen bolts to 13 ft. lbs. (1.8 mkg), using suitable tools (P 210 & P 211).

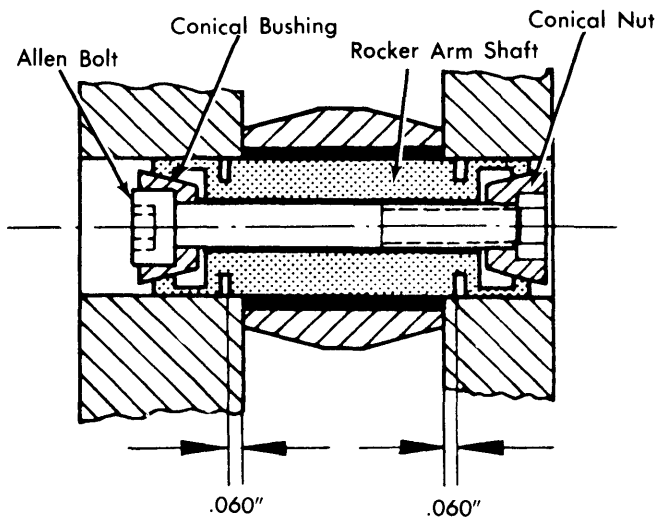

Fig. 2 Cross Sectional View of Rocker Arm Shaft Assembly

5) Install gasket, "O" ring, sealing flange, thrust plate, spacer, Woodruff key and camshaft sprocket flange as shown in Fig. 3. No provision is made to adjust camshaft end play, if sealing flange is worn, replace it.

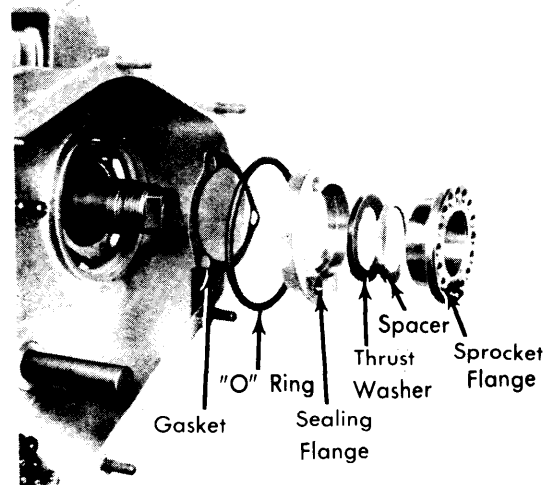

Fig. 3 Assembling Components to Install Camshaft Sprocket Flange and Sprocket

6) Install camshaft sprockets. Check chain alignment, see Fig. 12.

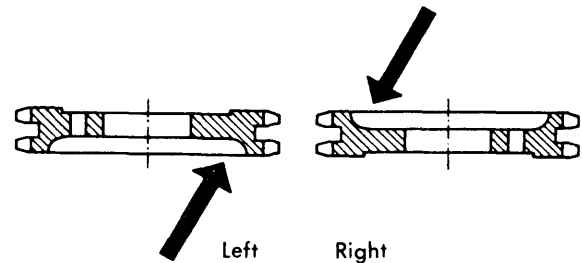

Fig. 4 Camshaft Sprocket Position (Viewed from Blower End of Engine)

7) Install heat exchanger before chain tensioner. Slide chain guides on mounting studs. With a screwdriver lift retaining spring and slide chain guide into place. Install chain tension pivot lever and sprocket. Check that oil holes in pivot stud face upward.

8) Fill and bleed chain tensioners, depress chain tensioners and install. Left chain tensioner may be positioned in only as far as to let camshaft nut to be installed after valve timing. See *Valve Timing*.

9) Install chain housing covers and camshaft oil lines. Reverse removal procedures for remaining components.

Porsche Engines

911 6 CYLINDER (Cont.)

VALVES							
Engine & Valve	Head Diam. In. (mm)	Face Angle	Seat Angle	Seat Width In. (mm)	Stem Diameter In. (mm)	Stem Clearance In. (mm)	Valve Lift In. (mm)
2687 cc Intake	1.80-1.81 (45.7-46.0)	45°	45°	.055-.062 (1.4-1.6)	.3526 (8.96)
Exhaust	1.57-1.58 (39.9-40.1)	45°	45°	.055-.062 (1.4-1.6)	.3518 (8.94)

VALVE ARRANGEMENT

All upper valves are intake.
All lower valves are exhaust.

VALVE GUIDE SERVICING

- 1) Drill out valve guide with a .433" (11 mm) drill from camshaft side of head. Drift out remaining valve guide into combustion chamber.
- 2) Using a hole gauge, measure guide bore in cylinder head. Turn oversize guide in a lathe until O.D. gives an interference fit of .0012-.0024" (.030-.061 mm).
- 3) Press valve guide into head from camshaft side until a measurement of .5196" (13.20 mm) is reached (see illustration). Use tallow as a lubricant when pressing in guides. Bore or ream guide I.D. to .3543-.3549" (9.0-9.01 mm).

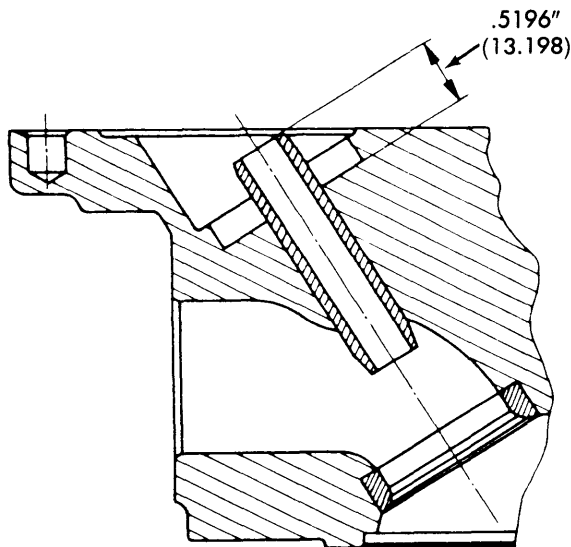

Fig. 5 Cross Sectional View of Valve Guide for Replacement

VALVE STEM OIL SEALS

- 1) Using a suitable spring compressor, remove valve keepers. Withdraw collar and springs. Remove valve stem oil seal from end of valve guide.
- 2) Slide a new oil seal over valve stem, using care not to damage seal as it passes over keeper grooves. Force seal over end of valve guide. Reverse removal procedure for springs, collar and keepers.

VALVE SPRINGS			
Engine	Free Length In. (mm)	① PRESSURE Lbs. @ In. (kg @ mm)	
		Valve Closed	Valve Open
2687 cc Intake	1.378 (35)
Exhaust	1.398 (35.5)
Carrera Intake	1.398 (35.5)
Exhaust	1.358 (34.5)

① — Measurement given is spring installed height; no pressure specification provided. See Valve Spring Servicing.

VALVE SPRING SERVICING

- 1) Using a suitable spring compressor, remove valve keepers and collar. Check springs for wear or fatigue, replace as necessary.
- 2) Install outer spring with closely wound coils next to cylinder head. Measure installed height of springs; add or remove spacers under valve spring to attain specified installed height.

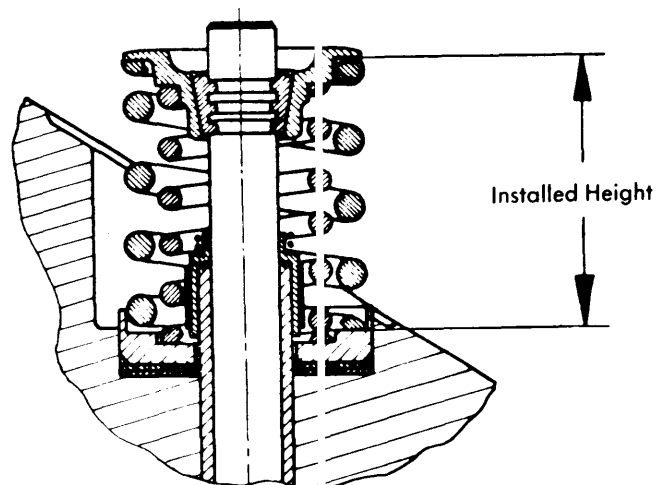

Fig. 6 Arrows Indicate Measurement Location Points for Valve Spring Installed Height

911 6 CYLINDER (Cont.)

ROCKER ARM ASSEMBLY

- 1) Using an Allen wrench, loosen rocker arm shaft bolt. Slide rocker shaft out of cylinder head and remove arm.
- 2) Check rocker arm shaft and rocker bushing for wear.

Application	Rocker Arm Specifications (In.)	
	Diameter	Wear Limit
Rocker Arm Bushing.....	.0709-.7094.....	.7106
Rocker Arm Shaft.....	.0708-.7084.....	.7074
Rocker Arm Width.....	1.015-1.019.....	1.011
Housing Width.....	1.023-1.029.....	1.033

- 3) Install rocker arm shaft. Center rocker arm shaft in housing, see Fig. 2. Tighten rocker arm Allen bolt.

NOTE — Install outside rocker arm shafts with Allen bolt facing either cylinder two or five.

VALVE CLEARANCE ADJUSTMENT

1) Valve clearance should be set to .004" (.10 mm) with engine cold. If valves or seats have been reground, set clearances to .010" (.25 mm), run engine for one-half hour, then reset valves to original cold clearance.

2) Adjust valves in firing order sequence 1, 6, 2, 4, 3 and 5. Rotate to TDC of firing stroke on No. 1 cylinder and adjust clearance.

3) Rotate engine 120° until No. 6 cylinder is at TDC and adjust. Rotate engine 120° for each cylinder to be adjusted.

PISTONS, PINS, RINGS						
Engine	PISTONS	PINS		RINGS		
	Clearance In. (mm)	Piston Fit In. (mm)	Rod Fit In. (mm)	Rings	End Gap In. (mm)	Side Clearance In. (mm)
911S & Carrera Uncoated ^①	.0010-.0018 (.025-.045)	Press Fit	.0007-.0015 (.018-.038)	No. 1	.008-.016 (0.2-0.4)	.0029-.0042 (.07-.11)
	.0011-.0020 (.028-.052)	Press Fit	.0007-.0015 (.018-.038)	No. 2	.006-.014 (.15-.35)	.0029-.0042 (.07-.11)
Coated ^②				No. 3	(.41-1.48)	(.02-.05)

- ① — Uncoated pistons installed in coated cylinders. See *Fitting Pistons in this article*.
 ② — Coated pistons installed in uncoated cylinders. See *Fitting Pistons in this article*.

OIL PAN REMOVAL

Remove nuts attaching oil pan (strainer cover plate). Remove strainer plate, gaskets and strainer. Clean strainer and cover plate. Using new gaskets, replace strainer and cover plate, making sure oil strainer hole slides over pickup tube.

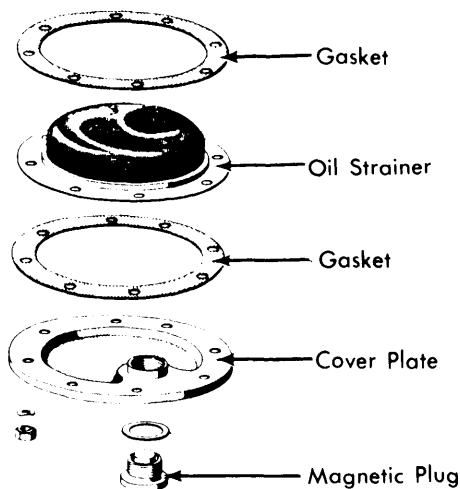

Fig. 7 Exploded View of Oil Strainer and Cover Plate

PISTON ASSEMBLY

NOTE — Connecting rods are not removed from crankshaft until crankcases are separated and crankshaft has been removed. Therefore pistons are removed with connecting rods still attached to crankshaft.

Mark piston and cylinder for proper relocation upon reassembly. Remove cylinders. Extract piston pin circlip, heat piston to approximately 176°F (80°C), and press out pin. Clean and inspect piston, rings, and pin for each cylinder. *NOTE* — See measurement procedures in *Fitting Pistons*. Replace parts as necessary.

FITTING PISTONS

Two different types of pistons are available in these models: (1) An uncoated piston installed in a coated (Nilasil) cylinder. This piston is stamped-marked "A2" on its face. (2) A coated (Ferrocoat) piston installed in an uncoated cylinder. Both types of pistons are manufactured by Mahle and have a raised pin bore enclosed open oil scraper ring for identification.

Porsche Engines

911 6 CYLINDER (Cont.)

NOTE — Coated pistons are also identified as "LS" type pistons. Manufacturer indicates it is possible to use the uncoated (Alusil) cylinders with coated ("LS") pistons in the same engine with the coated cylinders and uncoated pistons; however, it is important that only pistons and cylinders of the same weight group and dimensions be mixed. Therefore, in order to prevent possible "unbalanced" weights and sizes, manufacturer suggests that cylinders and pistons of same type and make be constant throughout the engine.

CAUTION — When installing pistons place large valve pocket (intake on Schmidt pistons) or flat (intake on Mahle pistons) facing toward intake valve (up).

1) Measure cylinder for wear and out-of-roundness. Cylinders are marked according to size (see Piston & Cylinder Specifications table) and are matched according to piston types (as described previously). Measure cylinder diameter at a point .08-.12" (2-3 mm) below the highest point of top ring travel; take one measurement in line with thrust face and another at 90° to this measurement. Cylinder is worn if diameter measurement is more than .004" (0.1 mm) beyond diameter specification. If difference in the two measurements is more than .0016" (.04 mm), then cylinder has exceeded its ovality limit.

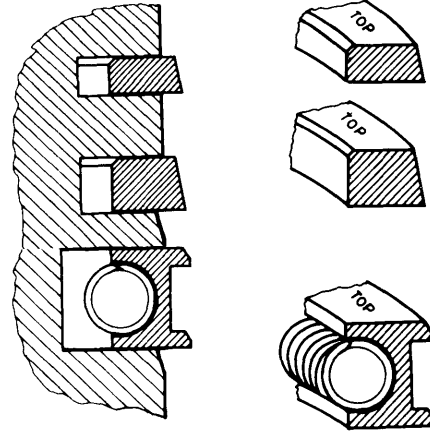

Fig. 9 Sectional View of Piston Ring Installation

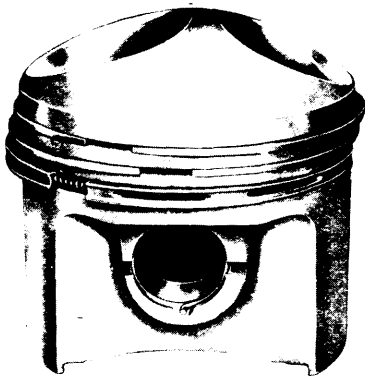

Fig. 8 Mahle Type Piston — Showing Piston Head Shape

Piston & Cylinder Specifications (All Standard Sizes)

Application & Marking	Piston Diam. In. (mm)	Cylinder Diam. In. (mm)
All Models (Uncoated)		
0	3.5433-3.5437 (90.00-90.01)	3.5421 (89.97)
1	3.5437-3.5441 (90.01-90.02)	3.5425 (89.98)
2	3.5441-3.5445 (90.02-90.03)	3.5429 (89.99)
911S & Carrera ("LS"/Mahle)		
0	3.5433-3.5438 (90.000-90.012)	3.5417-3.5422 (89.960-89.972)
1	3.5438-3.5442 (90.012-90.024)	3.5422-3.5427 (89.972-89.984)
2	3.5442-3.5447 (90.024-90.036)	3.5427-3.5431 (89.984-89.996)

2) Position rings in bottom of cylinder and measure ring gap. Check side clearance in piston ring grooves. Install rings on piston with marking "TOP" facing upward as showing in Fig. 9.

NOTE — All piston measurements are made .098" (2.49 mm) from the bottom of piston skirt.

CRANKSHAFT MAIN & CONNECTING ROD BEARINGS

Engine	MAIN BEARINGS				CONNECTING ROD BEARINGS		
	Journal Diam. In. (mm)	Clearance In. (mm)	Thrust Bearing	Crankshaft End Play In. (mm)	Journal Diam. In. (mm)	Clearance In. (mm)	Side Play In. (mm)
2687 cc Jrnls 1-7	2.2429-2.2436 (56.97-56.99)	.0003-.0028 (.008-.07)	No. 1	.0043-.0076 (.11-.19)	2.0460-2.0468 (51.97-51.99)	.0011-.0034 (.028-.086)
Jrnl 8	1.219-1.220 (30.96-30.99)	.004 (.10)					

911 6 CYLINDER (Cont.)

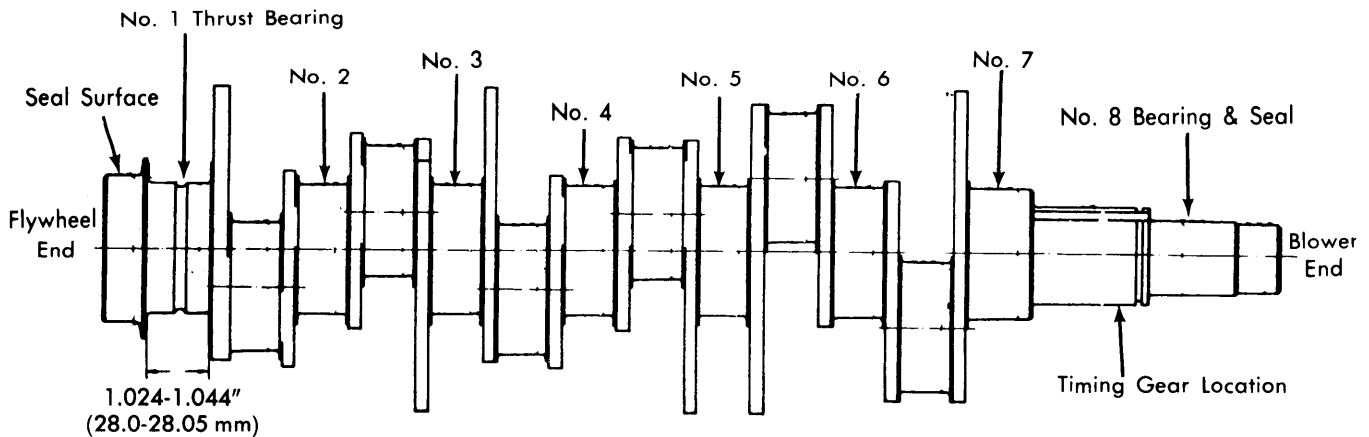

Fig. 10 Side View of Porsche Crankshaft with Detail of Bearing Locations

MAIN BEARING SERVICE

1) Separate crankcase halves. Lift out crankshaft and connecting rods. Place crankshaft on a suitable stand and remove connecting rods.

NOTE — Replace connecting bolts whenever rods are disassembled. Connecting rod bolts are stretch bolts and should never be reused.

2) Inspect crankshaft and connecting rods for wear, damage or out-of-true. Crankshaft main journals one through seven and all connecting rod journals have the same diameter. Replace bearings or fit undersize bearings as required.

3) Main bearing number eight is a special bearing with an external "O" ring and internal oil seal. A steel dowel pressed in crankcase is used to locate number eight bearing and prevent it from turning. Use care when installing bearing that dowel engages hole and not groove in bearing.

THRUST BEARING ALIGNMENT

Check end play at No. 1 main bearing. Width of No. 1 bearing is 1.1024-1.1044" (28.0-28.05 mm). Maximum wear limit is .011" (.28 mm) beyond specifications. Replace main bearing or crankshaft if excessive wear is present.

MAIN BEARING OIL SEALS (BLOWER END)

Remove belt pulley. Using a screwdriver, pry out old seal. Coat new seal with oil and press in place using suitable tool (No. P 216).

MAIN BEARING OIL SEAL SERVICE (FLYWHEEL END)

Remove flywheel. With a chisel or drift, displace oil seal. With a screwdriver pry out seal. Coat outer seal edges with sealing compound and press into crankcase until seal is flush with face of crankcase, using suitable tool (P 215).

INTERMEDIATE SHAFT BEARING SERVICE

With crankcase halves separated, lift out intermediate shaft and bearings. Inspect shaft and bearings for wear or damage. Replace shaft and bearings as necessary. No undersize bearings are available.

CAMSHAFT			
Engine	Journal Diam. In. (mm)	Clearance In. (mm)	Lobe Lift In. (mm)
2687 cc	1.8474-1.8481 (46.92-46.94)	.0009-.0025 (.023-.06)

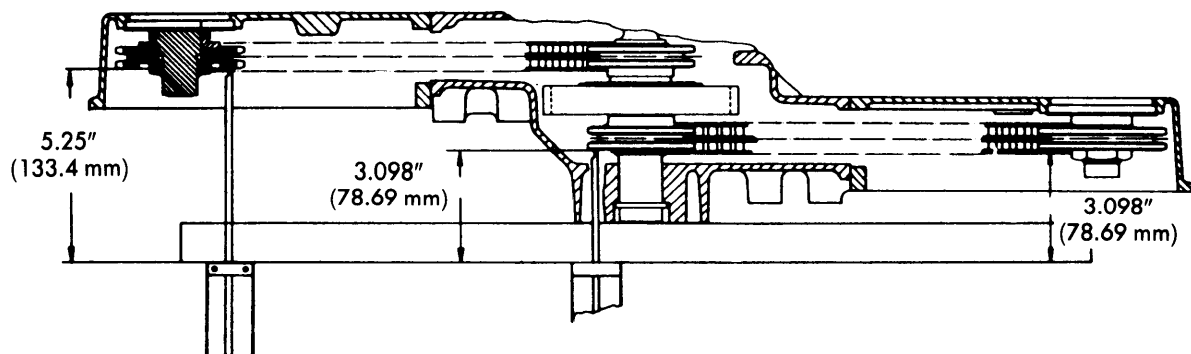

Fig. 11 Top View Showing Timing Chain Alignment

911 6 CYLINDER (Cont.)

Remove chain housing covers, chain tensioner and chain tensioner sprocket. Remove old chains. Install new chains. Reverse removal procedure to reassemble. Check valve timing and chain alignment, see Fig. 12.

CAMSHAFT REMOVAL

- 1) Remove rocker covers and rocker arm assemblies. Disconnect exhaust muffler. Remove oil hose from crankcase to chain housing cover. Remove chain tensioner and chain tensioner sprocket.
- 2) On 911S models, remove belt pulley from left camshaft. Remove bearing and chain housing covers. With a puller, remove ball bearing from camshaft.
- 3) Unscrew nuts attaching camshaft sprocket, using suitable tools (No. P 202 & P203). Using suitable tool (No. P 212), withdraw dowel pin from camshaft sprocket.
- 4) Pull sprocket and sprocket flange. Remove Woodruff key from camshaft. Remove three attaching screws, "O" ring and withdraw camshafts rearward.

NOTE — Camshafts are not symmetrical and must be replaced on side they were removed from during disassembly.

CAMSHAFT END THRUST

With a dial indicator measure camshaft end play. If end play is excessive replace aluminum thrust washer located behind camshaft sprocket flange.

VALVE TIMING				
Engine	INTAKE		EXHAUST	
	Open (ATDC)	Close (ALDC)	Open (BLDC)	Close (BTDC)
2687 cc 911S & Carrera	24°	2°	6°	50°

VALVE TIMING

- 1) Rotate crankshaft until mark "Z 1" on crankshaft pulley aligns with mark on crankcase.

NOTE — Use care when rotating crankshaft or camshafts so that valve and piston do not collide. If resistance is felt, backoff a little and rotate camshaft until you are free to continue.

- 2) Using suitable tool (No. P 202) to rotate camshaft until dot on end of shaft is on top of camshaft vertical center line (see illustration). Find a hole in camshaft sprocket which exactly

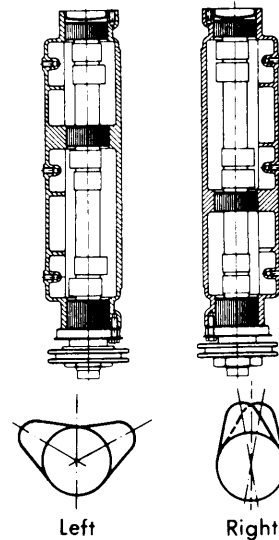

Fig. 13 Camshaft and Housing Location as Viewed from Blower End of Engine

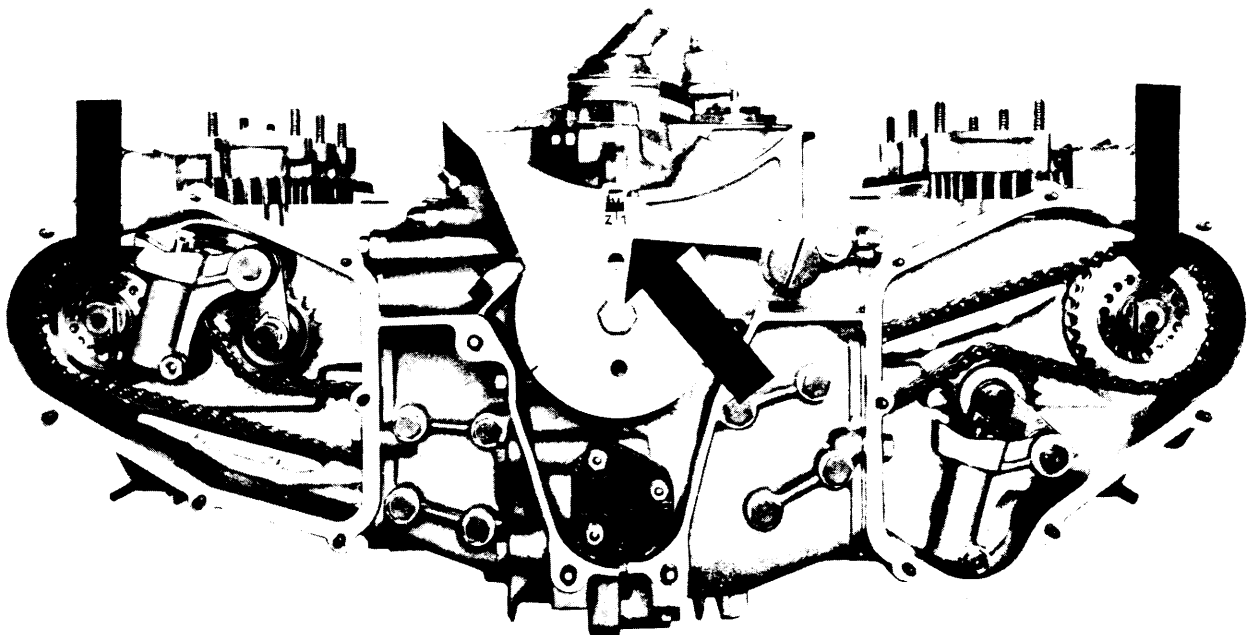

Fig. 12 Head on View of Engine Showing Valve Timing Marks

911 6 CYLINDER (Cont.)

2) Using suitable tool (No. P 202) to rotate camshaft until dot on end of shaft is on top of camshaft vertical center line (Fig. 14). Find hole in camshaft sprocket which exactly lines-up with camshaft flange and insert dowel pin. Install lock washer and nut.

3) Adjust cylinder No. 1 intake valve clearance to .04" (1 mm). Install a dial indicator with pressure foot resting squarely on valve spring collar. Preload dial indicator to .4" (10 mm) to provide for valve movement.

4) Using a screwdriver, depress chain tensioner on side to be measured and block it with piece of metal. Rotate crankshaft 360° until "Z 1" (TDC) mark is aligned with mark on

crankcase. Read dial indicator and compare with measurement given in *Intake Valve Lift Table*.

5) If correct valve opening measurement is not achieved, loosen camshaft nut, remove dowel pin and rotate camshaft until valve is open correct amount. Locate holes which align exactly and install dowel pin. Make sure crankshaft remains on TDC. Rotate crankshaft two complete revolutions and recheck valve lift, repeat timing procedure if necessary. Repeat procedure on No. 4 cylinder for other side of engine.

Intake Valve Lift

Application	In. (mm)
911S & Carrera016-.021 (.40-.54)

ENGINE OILING

Oil Capacity — 2.9 gals. (add 2.64 qts. if equipped with Sportomatic. At oil change, 2.64 gals. are replaced.

Oil Filter — Disposable canister type.

Normal Oil Pressure — Minimum 70 psi @ 5500 RPM with oil temperature at 175°F.

Pressure Relief Valve — Non-adjustable.

ENGINE OILING SYSTEM

Lubrication is dry sump type. Two independent oil pumps provided for pressure and suction in system. Pressure pump takes oil from an externally mounted oil tank and forces oil to individual oil passages for all main bearings. From main bearings a drilled passage in crankshaft carries oil to connecting rod bearings. Another passage leads to front bearing of intermediate shaft. A passage in intermediate shaft takes oil to rear bearing of shaft.

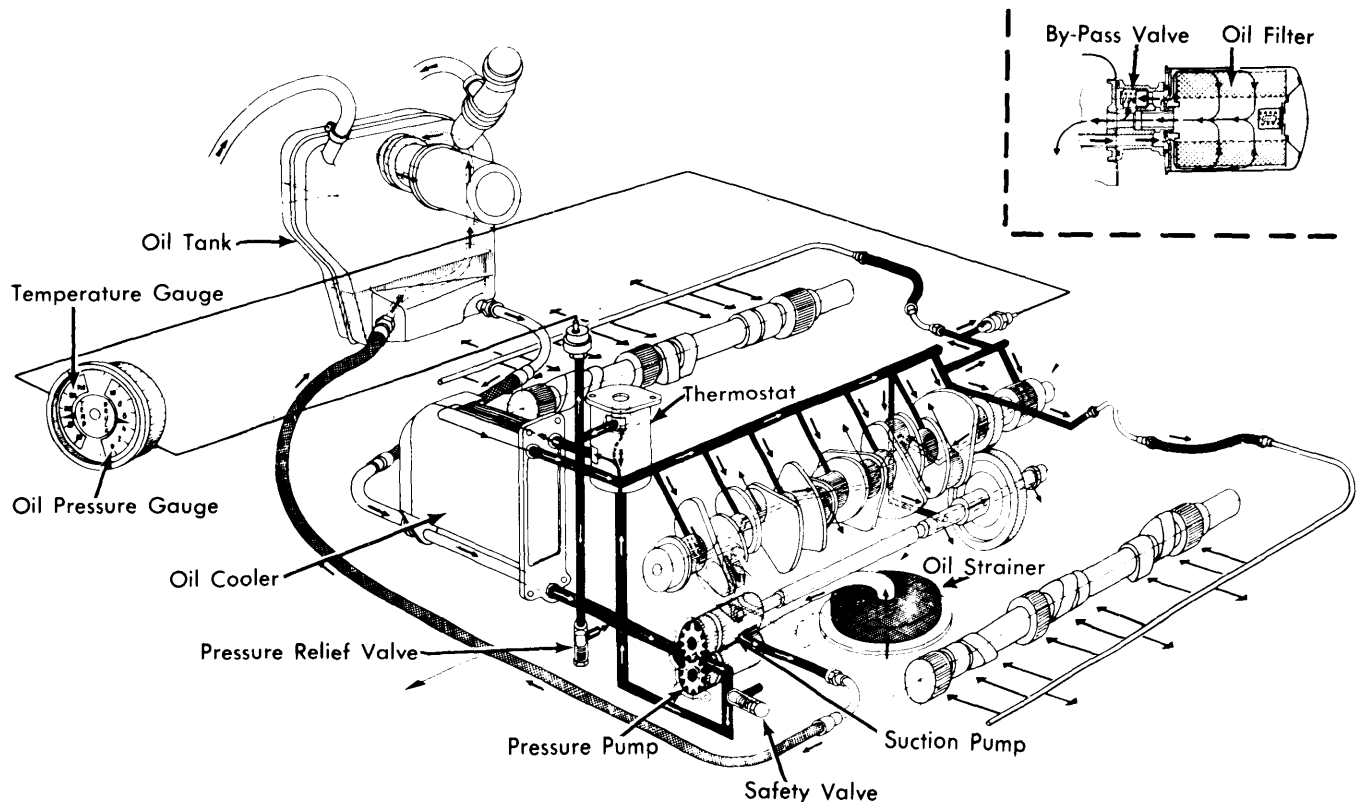

Fig. 14 Diagram Showing Porsche Engine Oil System

Porsche Engines

911 6 CYLINDER (Cont.)

ENGINE OILING (Cont.)

Camshaft oiling is accomplished by external oil lines leading to camshaft housings. Camshaft housings contain aluminum tubes with holes; three holes of .120" diameter carry oil to camshaft bearings. Six holes of .040" diameter splash oil on camshaft lobes. Remaining three holes allow oil to splash against intake valve cover in such a manner that it will drip on rocker arms and valve stems.

Suction pump takes oil from engine sump through a strainer and forces it through oil filter to oil tank. Oil collected in lower part of camshaft housing is returned to crankcase by oil return pipes. Suction pump then returns oil to oil tank. A tube in oil tank carries oil to base of oil tank and filter.

Oil pressure regulation is controlled by means of four separate valves. A thermostatically controlled valve directs oil directly to engine when temperature is below 176°F. When temperature

is above 176°F oil flows through oil cooler and then to main bearings. A pressure relief and safety valve located in right crankcase half opens if oil pressure rises above 76.9-99.6 psi and oil is passed directly into crankcase. A safety valve is mounted in left crankcase half immediately after oil pump. It operates in event of a defective pressure relief valve to prevent damage to oil cooler or oil lines. As a safety measure, by-pass valves are built into filter base and filter body. If oil pressure exceeds 28.4 psi, oil by-passes oil filter and flows directly into oil tank.

OIL PUMP

Oil pump may be removed when crankcase halves are separated. No repair of pump is possible, replace if defective.

ENGINE COOLING

Cooling is accomplished by means of a blower, consisting of an impeller and blower housing. Center of blower housing holds support for alternator. Impeller and belt pulley are attached to alternator shaft. Blower delivers air required for cooling engine, oil cooler, alternator as well as fresh air for heating system. Cooling air flows through upper molded plastic air guides to cylinders and heads. Baffle plates provide uniform distribution of air. A duct incorporated into upper air guide leads air flow directly to oil cooler. Ducting for air delivery to heat exchangers is on both sides of blower housing. Adjustment of blower drive belt is done by adding or removing spacers between impeller housing and pulley half. This will cause belt to ride higher or lower on pulley, thereby loosening or tightening drive belt.

TIGHTENING SPECIFICATIONS

Application	Ft. Lbs. (mkg)
Crankcase Joining Bolts	18 (2.5)
Camshaft Housing	16 (2.2)
Main Bearing Caps	25 (3.5)
Flywheel	108 (15)
Connecting Rod Caps	36 (5.0)
Cylinder Heads	24 (3.3)
Camshaft Nut	72 (10)
Rocker Arm Shafts	13 (1.8)
Crankshaft Pulley	58 (8.0)
Alternator	29 (4.0)