

## MGB 4 CYLINDER

GENERAL SPECIFICATIONS										
Year	Displ.		Carburetor	HP at RPM	Torque (Ft. Lbs. at RPM)	Compr. Ratio	Bore		Stroke	
	cu. ins.	cc					in.	mm	in.	mm
1975	109.8	1798	2x1	...	...	9.1-1	3.16	80.26	3.5	89

### ENGINE IDENTIFICATION

Engine identification and serial number are stamped on plate secured to right hand side of crankcase.

### ENGINE REMOVAL

It is possible to remove only the engine from car, but it is recommended that engine and transmission be removed as complete assembly.

- 1) Disconnect battery cables and remove hood. Drain oil and coolant. Disconnect oil cooler and oil pressure gauges from engine and remove oil cooler mounting bolts. Remove radiator and oil cooler, complete with hoses.
- 2) Disconnect wiring from generator or alternator, and from distributor. Remove spark plug wires from plugs and remove distributor cap. Disconnect heater hoses and heater control cable.
- 3) Disconnect water temperature sending unit, disconnect wiring from starter. Disconnect fuel line, choke cables, and remove air cleaners from carburetors. If tachometer is mechanical type disconnect it.
- 4) On cars equipped with manual transmission and overdrive, remove gear lever plate, raise rubber boot and remove lever retaining bolts. Remove gear lever. Disconnect wiring from back-up switch and overdrive switch. Disconnect clutch slave cylinder from transmission housing and move it clear of housing.
- 5) On cars equipped with automatic transmission, disconnect downshift cable from carburetors and disconnect gear lever from transmission. Disconnect wiring from neutral start switch and from back-up switch.
- 6) Disconnect speedometer cable from transmission and using engine hoist, take up the weight of engine. Support transmission. Disconnect exhaust pipe from exhaust manifold and release pipe clip from transmission housing. Disconnect and remove propeller shaft. Remove front engine mount bolts.
- 7) Remove four bolts holding crossmember to frame and remove two bolts holding bottom tie bracket to crossmember. Lower transmission so that it rests on fixed crossmember. Remove rear mounting nuts and remove crossmember.

8) Ease assembly forward until transmission is clear of crossmember, then tilt assembly and lift out of car. Remove transmission from engine if necessary.

### INTAKE & EXHAUST MANIFOLDS

**Removal** – Remove air cleaners and carburetors and disconnect distributor vacuum line. Remove manifold stud nuts and remove manifold.

**Installation** – Reverse removal procedure using new gasket. Center manifold stud nuts have large washers which hold both intake and exhaust manifolds. Outside nuts have small washers and hold exhaust manifold only.

### CYLINDER HEAD

**Removal** – 1) Drain cooling system and remove top radiator hose. Remove thermostat housing and thermostat. Remove air cleaners, carburetors and exhaust and intake manifolds. Remove rocker assembly and seven external cylinder head nuts at same time, loosening a turn at a time until all load is released.

2) Disconnect spark plug wires and remove spark plugs. Disconnect heater hose and heater control cable from water valve. Remove water temperature sensor from front of cylinder head and release conductor from its support clip.

3) Loosen clips and disconnect hoses from water pipe on left side of cylinder head. Remove pipe. Remove distributor vacuum line from rear cylinder head stud and remove cylinder head.

**Installation** – 1) Thoroughly clean all gasket surfaces and install new gasket. Place cylinder head in position and replace vacuum control line bracket. Install seven cylinder head external nuts finger tight and replace push rods.

2) Replace rocker arm assembly, securing nuts finger tight. Tighten 11 cylinder head nuts a turn at a time in sequence. Tighten four rocker arm assembly nuts and reverse removal procedure for remaining items.

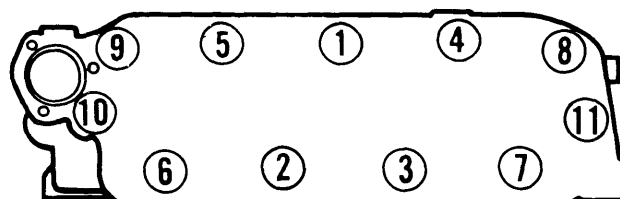

Fig. 1 MGB Cylinder Head Tightening Sequence

## MGB 4 CYLINDER (Cont.)

VALVES							
Engine & Valve	Head Diam. In. (mm)	Face Angle	Seat Angle	Seat Width In. (mm)	Stem Diameter In. (mm)	Stem Clearance In. (mm)	Valve Lift In. (mm)
1798 cc Int.	1.625-1.630 (41.27-41.40)	45.5°	45.5°	...	.3429-.3434 (8.70-8.72)	.0008-.0018 (.020-.046)	.3645 (9.25)
Exh.	1.343-1.348 (34.11-34.23)	45.5°	45.5°	...	.3417-.3422 (8.68-8.69)	.002-.003 (.051-.076)	.3645 (9.25)

## VALVE ARRANGEMENT

E-I-I-E-E-I-I-E (front-to-rear).

## VALVE GUIDE SERVICING

1) Remove cylinder head and valves. Rest cylinder head with machined face downward on a clean surface. Drive valve guide downwards into combustion space with a suitable drift. This should be a hardened steel punch 9/16" in diameter and not less than 4" in length, with a starting diameter of 5/16" for locating and engaging bore of guide.

2) When installing new guides, they should be driven in from top of cylinder head. Guides must be inserted with end having largest chamfer at top. Guides should be driven into combustion spaces until exhaust valve guides are 5/8" and intake valve guides are 3/4" above machined surface of valve spring seating.

Intake .750" (19.05 mm)

Exhaust .625" (15.86 mm)

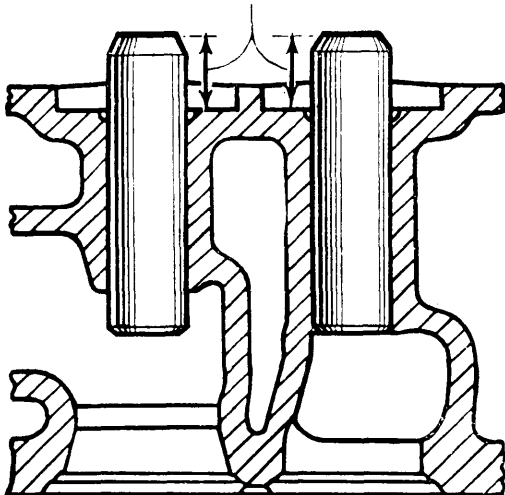

Fig. 2 Cross Sectional View of Installed Valve Guide

## VALVE SPRINGS

**Removal** — With cylinder head and rocker arm assembly removed, remove valve circlip. Compress springs using suitable tool (18G45), and remove two valve keepers. Release valve springs and remove compressor, valve spring retainer, spring and bottom retainer. Remove "O" ring seal from keeper groove and remove valve from guide.

**Installation** — Reverse removal procedure using new valve "O" ring seals. Soak rings in clean engine oil for a short time before use to ease installation.

## ROCKER ARM ASSEMBLY

**Removal** — 1) Drain cooling system and disconnect breather pipe from rocker cover. Remove throttle cable, remove two rocker cover attaching nuts and lift off rocker cover. Take care not to damage cork gasket or lose washers or rubber seals.

2) Notice that under the right rear rocker stud nut there is a locking plate. Unscrew eight rocker shaft bracket nuts and external cylinder head nuts gradually, one turn at a time, until all load is released.

**NOTE** — It is important that external cylinder head nuts are loosened at same time to avoid possibility of head distortion and water entering cylinders.

3) Remove all rocker shaft bracket nuts and remove rocker assembly, complete with brackets and rockers. Remove push rods, arranging them so that they may be replaced in same positions.

## ROCKER ARM DISASSEMBLY

1) Remove set screw which locates rocker shaft in rear rocker mounting bracket and remove split pins, flat washers, and spring washers from each end of shaft. Slide rockers, brackets, and springs off the shaft.

2) To reassembly, reverse disassembly procedure and replace rockers and springs in their original positions. Remember to replace rocker shaft locating screw lock plate.

## ROCKER BUSHING REPLACEMENT

1) Using suitable tool (18G226), place rocker on anvil and drive out worn bushing. Place new bushing on driver and position bushing with butt joint at top of rocker bore and oil groove in bushing at bottom of rocker bore.

VALVE SPRINGS			
Engine	Free Length In. (mm)	PRESSURE Lbs. @ In. (kg @ mm)	
		Valve Closed	Valve Open
1798 cc	1.92 (48.8)	82 @ 1.44 (37.2 @ 36.6)	142 @ 1.08 (64.4 @ 27.4)

## MGB 4 CYLINDER (Cont.)

2) It is necessary to drill oil holes in bushing to coincide with oilways in rocker. Holes may be drilled either before or after installation.

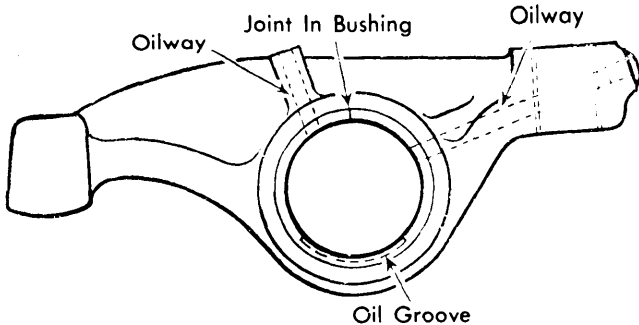

Fig. 3 Rocker Arm Bushing with Detail of Oil Holes

3) If holes are drilled after installation, remove adjuster screw and use .093" (2.36 mm) drill to extract end plug and to continue oilway through bushing. Replug end after operation us-

ing a rivet and weld rivet into position. Oil hole in top of rocker barrel must be continued through the bushing with a No. 47 drill. Finally, burnish ream bushing to .6255-.6260" (15.89-15.90 mm).

### VALVE CLEARANCE ADJUSTMENT

Remove valve cover and observe opening and closing of valves. To check clearances, turn crankshaft until valves in first column are fully open, then valves in second column may be checked and adjusted to .015" (.381 mm). Set clearance with engine cold.

Valves Open	Valves to Adjust
1	8
3	6
5	4
2	7
8	1
6	3
4	5
7	2

PISTONS, PINS, RINGS						
Engine	PISTONS	PINS		RINGS		
	Clearance In. (mm)	Piston Fit In. (mm)	Rod Fit In. (mm)	Rings	End Gap In. (mm)	Side Clearance In. (mm)
1798 cc	① .0021-.0033 (.053-.084)	③	Press Fit	No. 1	.012-.022 (.30-.56)	.0015-.0030 (.038-.076)
	② .0006-.0012 (.015-.030)			No. 2	.012-.022 (.30-.56)	.0015-.0030 (.038-.076)
				No. 3	.015-.045 (.38-1.14)	.0008-.0068 (.020-.173)

- ① - Top.
- ② - Bottom.
- ③ - Hand Push Fit at 60°F (15.6°C).

### OIL PAN REMOVAL

1) Drain engine oil and drain coolant. Disconnect radiator hoses and remove engine front mounting bolts. Lift engine enough to gain access to front oil pan bolts.

2) Remove all oil pan bolts and remove oil pan from engine. To install, reverse removal procedure using new oil pan gasket.

### PISTON & ROD REMOVAL

1) Remove cylinder head and oil pan. Pistons and rods must be removed from top of cylinder block. Unlock and remove big-end bolts and remove bearing caps. Release connecting rods from crankshaft.

2) Remove piston and rod assembly from top of cylinder block and reinstall bearing cap. Big-end bearing caps are offset. Make sure that parts are marked so they may be reassembled in original positions.

### FITTING PISTONS

All oversize pistons are marked with the actual oversize bore. The running clearance has been allowed for in the machining.

### PISTON RINGS

When replacing piston rings, note that the second and third compression rings are tapered and marked with letter "T", indicating top of ring. Make sure that ring to groove clearance and end gap are within limits before installing piston rings.

### PISTON PINS

Piston pins are press fit and are fully interchangeable in complete sets with earlier assemblies which have full floating pin. Use suitable tool or press to remove or install pins.

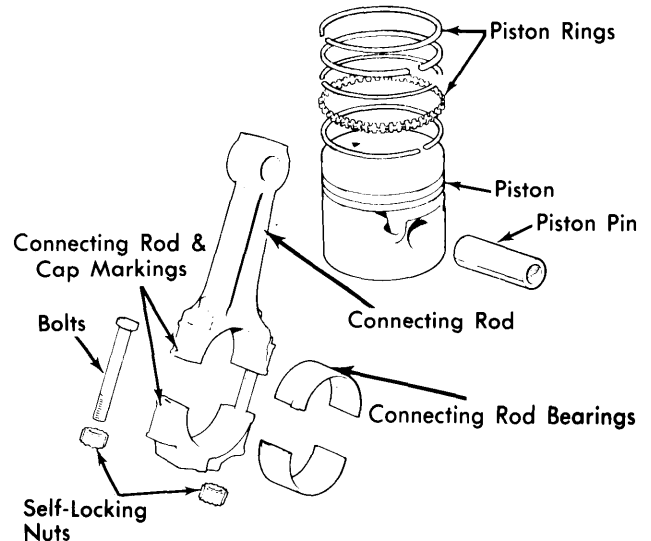

Fig. 4 Exploded View of Piston and Rod Assembly

## MGB 4 CYLINDER (Cont.)

CRANKSHAFT MAIN & CONNECTING ROD BEARINGS							
Engine	MAIN BEARINGS				CONNECTING ROD BEARINGS		
	Journal Diam. In. (mm)	Clearance In. (mm)	Thrust Bearing	Crankshaft End Play In. (mm)	Journal Diam. In. (mm)	Clearance In. (mm)	Side Play In. (mm)
1798 cc	2.1262-2.1270 (54.005-54.026)	.0010-.0027 (.025-.068)	Center	.004-.005 (.10-.13)	1.8759-1.8764 (47.648-47.660)	.001-.0027 (.025-.068)	.008-.012 (.20-.30)

**CRANKSHAFT REMOVAL**

Remove engine and remove clutch and flywheel. Remove timing cover, timing wheels and chain. Remove oil pan, oil pump strainer and rear engine mounting plate. Remove big end bearing cap and then take off main bearing caps. Lift crankshaft out of bearings, first marking bearings and bearing caps for correct replacement.

**FLYWHEEL REMOVAL**

- 1) Remove engine. Remove clutch by unscrewing six bolts and spring washers holding it to flywheel. Release bolts a turn at a time to avoid distortion of cover flange.
- 2) Three dowels locate clutch cover on flywheel. Unlock and remove 6 nuts and three lock plates which hold flywheel to crankshaft and remove flywheel.
- 3) When replacing flywheel, make sure that No. 1 and No. 4 timing mark on flywheel is in line with and on same side as first and fourth throws of crankshaft. A depression in crankshaft flange face is stamped with a similar timing mark. These should be in line with the one on flywheel periphery.

**CONNECTING ROD BEARINGS**

To remove bearings, bend down locking strips so that bolts may be removed. Remove connecting rod caps and extract bearings. No scraping of bearings is required as bearings are machined to give correct clearance of .0016" (.041 mm).

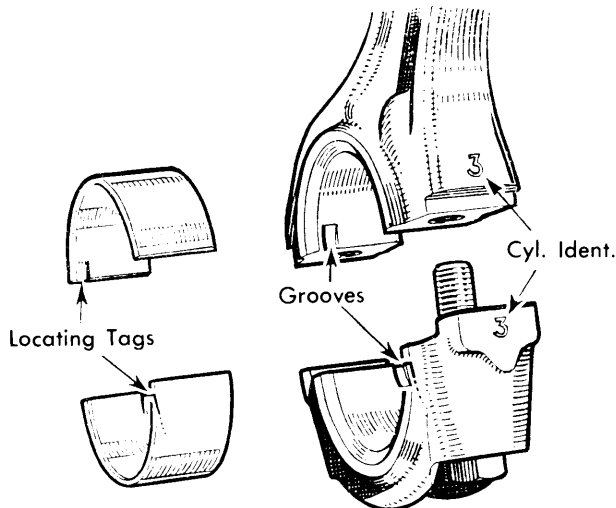

Fig. 5 Connecting Rod Bearings with Detail for Installation

**MAIN BEARINGS**

- 1) Remove engine from car and remove flywheel and clutch, timing chain, oil pan and oil strainer. Remove rear engine mounting plate. Remove two bolts and locking plate holding front main bearing cap to engine front plate. Remove main bearing cap retaining nuts and remove caps and bearings.
- 2) Bearings are machined to give correct clearance of .001-.0027". When replacing bearings that have been used but are

not damaged or worn, make sure that bearing and all surfaces are thoroughly cleaned. Rear main bearing cap horizontal joint surface should be lightly covered with Hylomar Jointing Compound or equivalent before cap is fitted to cylinder block. Tighten bearing cap nuts.

**THRUST BEARINGS**

A thrust washer is fitted on each side of center main bearing to take crankshaft end thrust. Washers each consist of two semi-circular halves, one having a lug located in recess in removable half of bearing and other one being plain. Washers are available in standard and .003" (.076 mm) oversize.

**FRONT COVER & OIL SEAL**

**Removal** - Drain cooling system and remove radiator. Loosen generator or alternator holding bolts and remove fan belt. Remove bolts holding steering rack to body and ease rack assembly forward enough to allow crankshaft pulley to be removed. Remove crankshaft pulley retaining bolt and remove pulley. Remove timing cover bolts and remove cover.

**Installation** - 1) Oil seal in timing cover should be renewed if necessary. Make sure that oil thrower behind crankshaft pulley is attached with face marked "F" away from engine. Fill annular groove between lips of oil seal with grease. Lube hub of pulley and push into seal. At same time turn pulley to avoid damage to seal.

2) With new gasket in place slide pulley onto shaft with keyway in line with key in crankshaft. Turn cover as necessary to align bolt holes with those in crankcase. Do not strain cover against flexibility of seal. Insert and tighten bolts, replace and tighten pulley attaching bolt.

CAMSHAFT			
Engine	Journal Diam. In. (mm)	Clearance In. (mm)	Lobe Lift In. (mm)
1798 cc			
Front	1.7887-1.7892 (45.433-45.446)	.001-.002 (.025-.051)	.250 (6.35)
Center	1.7288-1.7292 (43.912-43.922)		
Rear	1.6227-1.6232 (41.217-41.229)		

**TIMING CHAIN**

**Removal** - 1) Drain cooling system, remove radiator, crankshaft pulley and timing chain cover. Remove bottom plug from chain tensioner, insert 1/8" Allen wrench in cylinder and turn key clockwise until rubber slipper head is fully retracted and locked behind limit peg.

2) Remove bolts attaching tensioner and remove tensioner and backplate. Unlock and remove camshaft sprocket nut and lock washer. Ease both sprockets forward a fraction at a time with suitable small levers, and remove sprocket and chain.

## MGB 4 CYLINDER (Cont.)

**NOTE** — Use care not to lose gear packing washers behind crankshaft gear wheel. Make sure to replace the same number of washers as removed. To determine correct thickness of washers to be used if new camshaft or crankshaft components have been installed, place straight edge across sides of camshaft wheel teeth and measure gap between straight edge and crankshaft gear. Subtract .005" (.13 mm) from reading and add resultant thickness of crankshaft gear packing washers.

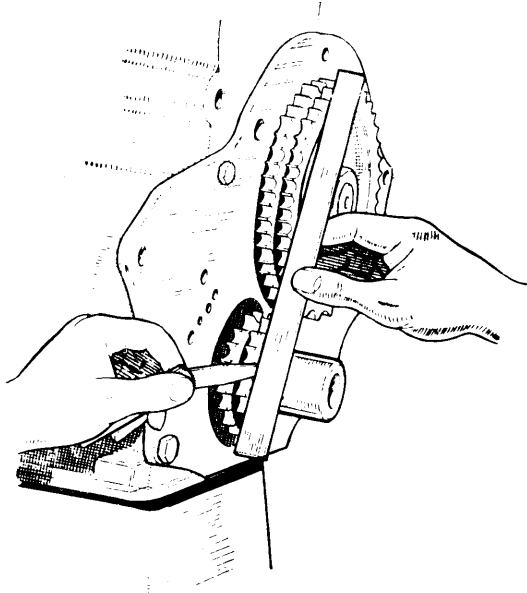

Fig. 6 Using a Straightedge to Align Chain Sprockets

**Installation** — 1) When replacing timing chain and gears, set crankshaft with keyway at TDC and camshaft with keyway about one o'clock position. Assemble gears into timing chain with two marks on gear wheels opposite each other.

2) Keep gears in this position and engage crankshaft gear keyway with key on crankshaft and rotate camshaft until camshaft gear keyway and key are aligned. Push gears onto shafts as far as they will go and tighten with lock washer and nut. Replace oil thrower with face marked "F" away from engine and replace remaining components.

### CAMSHAFT REMOVAL

1) Disconnect battery and remove intake and exhaust manifolds. Remove push rods and remove tappets. Remove timing cover, timing chain and timing gears.

2) Disconnect distributor vacuum line at distributor and remove two bolts with flat washers which hold distributor to housing. Do not loosen clamping plate bolt or ignition timing will be disturbed. Remove distributor assembly.

3) Remove oil pan, oil pump and oil pump drive shaft. If drive type tachometer is used, disconnect drive and remove nuts and washers and remove drive gear. Remove three set screws and shakeproof washers that hold camshaft locating plate to cylinder block. Remove camshaft.

4) Before reassembly, fix camshaft thrust plate and sprocket to camshaft, then check end play. Obtained specifications should not exceed .003-.007" (.08-.18 mm). Make measurement between retaining plate and thrust face of camshaft front journal.

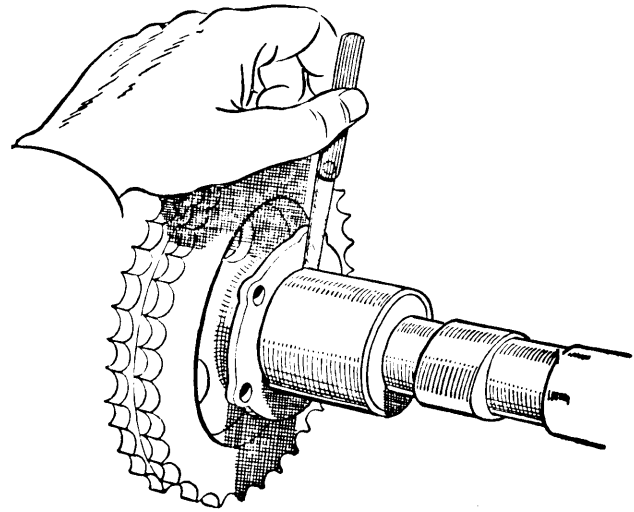

Fig. 7 Using a Feeler Gauge to Measure Crankshaft End Play

### CAMSHAFT BEARING SPECIAL TOOL

Old camshaft bearings can be punched out, new ones must be tapped into position. Bearings are easily damaged and use of suitable tool (18G 124A) is recommended. Tool consists of a body with built in thrust race, screw wing nut, stop plate, "C" washer and handle. Tool is used in conjunction with suitable adaptors (18G 124B, 124C, 124F, 124H).

### FRONT & REAR BEARING REMOVAL

1) Insert small end of suitable adaptor (18G 124F) into camshaft front bearing from inside cylinder block. Thread body of tool onto center screw and pass screw through adaptor from front of block.

2) Place slotted washer on flat at rear of center screw and insert bar into center screw behind slotted washer. Tighten wing nut to remove worn bearing.

3) Use same method for removing rear bearing using suitable adaptor (18G 124B).

4) To install new bearings, place bearing on smallest diameter of suitable adaptor (18G 124F) and insert into camshaft front bore from inside block, largest diameter first. Line up oil holes in bearing and cylinder block and make certain they remain aligned during operation.

5) Thread body of tool onto center screw and pass screw through adaptor located in front bearing. Position larger of two "C" washers on center screw with cutaway part turned away from butt joint of bearing. This joint must be covered by washer.

6) Place slotted washer on flat at rear of center screw and insert bar into screw behind slotted washer. Tighten wing nut and pull bearing into position.

7) Using suitable adaptor (18G 124B), use same method for replacing rear bearing.

### CENTER BEARING REMOVAL

1) Insert suitable stepped pilot adaptor (18G 124H) into camshaft front bore from inside block. Insert suitable adaptor (18G 124C) into center bearing from rear, small end first.

## MGB 4 CYLINDER (Cont.)

2) With body of tool positioned on center screw, pass screw through pilot adaptor and adaptor in center bearing. Place slotted washer on flat at rear of center screw and insert bar into screw behind slotted washer. Tighten wing nut to remove worn bearing.

3) To install bearing, insert stepped pilot adaptor into camshaft front bearing from inside block. Place new bearing on small end of suitable adaptor (18G 124C) and position in center bearing from rear, largest diameter first. Make sure oil holes in bearing and cylinder block line up and remain aligned during operation.

4) With body of tool positioned on center screw, insert screw through pilot adaptor and adaptor in center bore. Position larger of two "C" washers on center screw with cutaway portion turned away from butt joints of bearing. Joint must be covered by washer.

5) Place slotted washer and bar in center screw and tighten wing nut to pull bearing into position.

### CAMSHAFT BEARING REAMING TOOL

Before camshaft can be reassembled, bearings must be reamed in line to obtain correct clearance between shaft journals and bearings. Use suitable tools (18G 123A). Tool should consist of an arbor, bar, Allen wrench, and must be used with suitable adaptors (18G 123B, 123E, 123F, 123L, 123T, 123AB, 123AC, 123AD).

### FRONT & REAR BEARING REAMING

1) Insert suitable taper pilots (18G 123AB & 123AC) into center and rear bearings. Place suitable pilot (18G 123L) on arbor, followed by suitable cutter (18G 123E). Pass arbor through front bearing and pilot in center liner.

2) Place suitable cutter (18G 123B) on arbor and push arbor through taper pilot on rear bearing. Secure cutters and pilots in respective positions making sure cutter locating pins are engaged in correct numbered hole in arbor.

3) Cutter for front bearing will cut first with arbor piloting in center and rear bearings. Clean cuttings and filings away frequently during operation. Cutter for rear bearing will follow arbor piloting in front and center bearings. Make sure that all cuttings are cleared away before plain pilot is allowed to enter front bearing. When cut in rear bearing is finished, free cutters and remove arbor.

### CENTER BEARING REAMING

1) Insert suitable pilots (18G 123T & 123AD) in front and rear bearings. Pass arbor through pilot in front bearing and place cutter for center bearing on arbor. Push arbor through center bearing and pilot located in rear bearing.

2) Hold cutter and pilots in position, make sure locating pin of cutter engages correct numbered hole in arbor. Ream bearing, release cutter and remove arbor.

VALVE TIMING				
Engine	INTAKE		EXHAUST	
	Open (BTDC)	Close (ABDC)	Open (BBDC)	Close (ATDC)
1798 cc	16°	56°	51°	21°

### VALVE TIMING

1) Set No. 1 cylinder intake valve clearance to .055" with engine cold. Turn crankshaft until valve is about to open. Indicator groove in flange of crankshaft pulley should be opposite longest pointer on indicator bracket beneath crankshaft pulley, indicating TDC.

2) After timing has been checked, valve clearance should be reset. See *Valve Clearance Adjustment*.

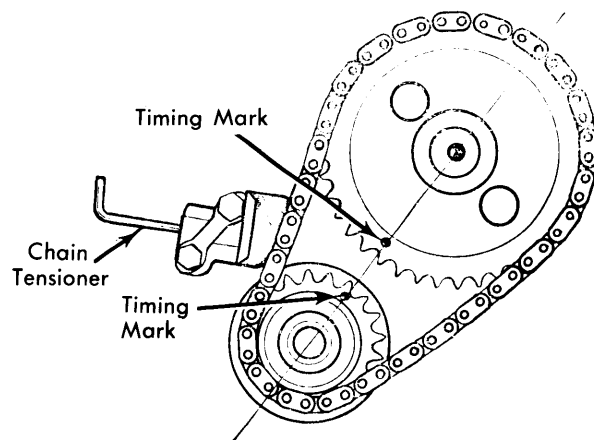

Fig. 8 Sprocket Alignment with Detail of Chain Tensioner

## ENGINE OILING

**Crankcase Capacity** — 6 pts. including filter. Add 1 ¼ pts. with oil cooler.

**Oil Filter** — Full flow type with disposable cartridge.

**Oil Pressure** — 10-25 psi (.7-1.7 kg/cm<sup>2</sup>) @idle: 50-80 psi (3.5-5.6 kg/cm<sup>2</sup>) @2000 RPM.

### ENGINE OILING SYSTEM

Force feed type with rotor type oil pump. A full-flow type oil filter is used. An oil pressure relief valve is used to enable oil to by-pass filter if oil filter becomes blocked.

## MGB 4 CYLINDER (Cont.)

### OIL PUMP

Two bolts hold on oil pump cover and three studs hold pump to crankcase. To remove pump, remove stud nuts and remove pump and drive shaft. To disassemble, proceed as follows:

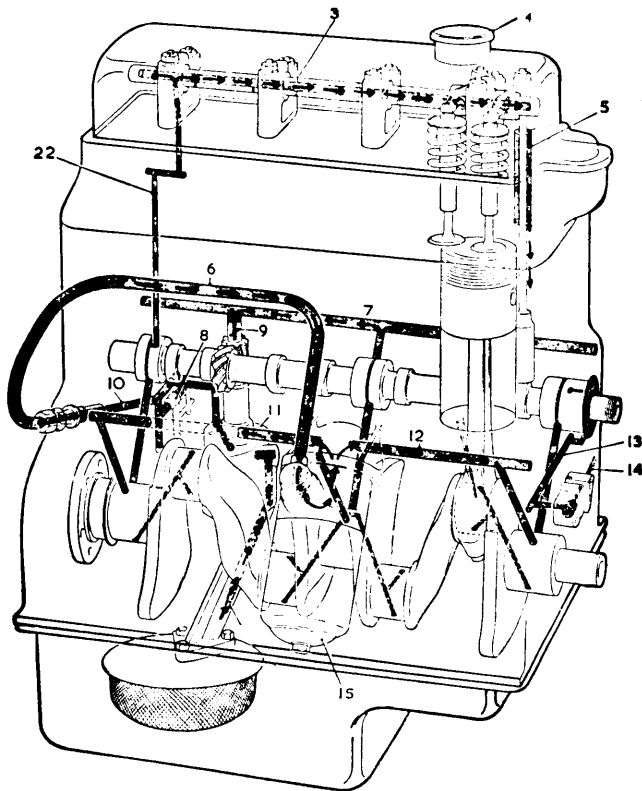

Fig. 9 Diagram Showing Engine Lubrication Distribution

1) Remove cover, located at base of oil pump by two dowels. Remove outer rotor complete with oil pump shaft. Clean all parts in kerosene and inspect for wear.

2) Rotor end play should be checked as follows: Install rotors in pump body and place straightedge across joint face of pump body. Measure clearance between top face of rotors and underside of straightedge. Clearance should not exceed .005" (.13 mm). If clearance is excessive, remove two cover locating dowels and tap the joint face of pump body.

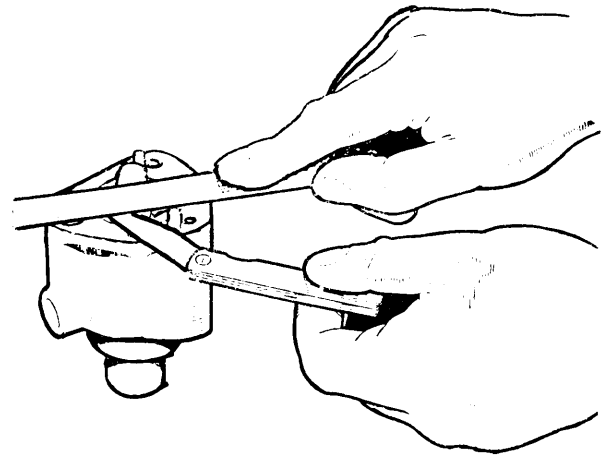

Fig. 10 Measuring Oil Pump Rotor End Play

3) Check clearance between outer rotor and rotor pocket in pump body. If clearance exceeds .010" (.25 mm), pump rotor, pump body, or complete pump assembly should be replaced.

4) Measure clearance of rotor lobes with rotors installed in pump body. If clearance exceeds .006" (.15 mm), rotors must be replaced.

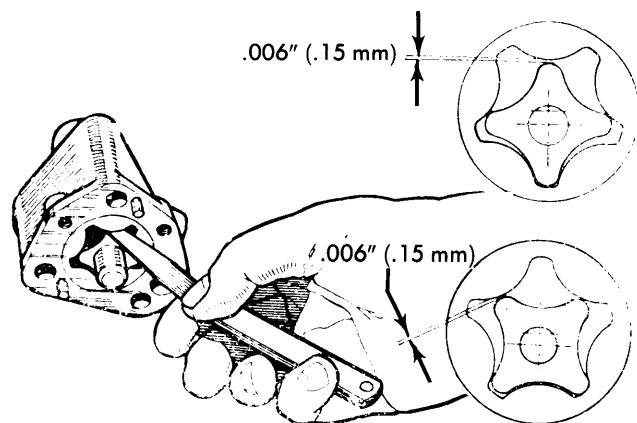

Fig. 11 Measuring Oil Pump Rotor Lobe Clearance

5) Reassemble pump and lubricate all parts with clean engine oil. Make sure outer rotor is installed in pump body with chamfered end at drive end of rotor pocket in pump body.

## MGB 4 CYLINDER (Cont.)

### ENGINE COOLING

**Cooling System Capacity** - 11.4 pts. Add .6 pts. with heater.

**Thermostat** - Setting of 175°F (80°C) is standard. An optional thermostat for cold climate with a setting of 180°F (82°C) is available.

**Pressure Cap** - Maintains pressure at 7 psi.

### WATER PUMP REPLACEMENT

1) Drain cooling system, remove top and bottom radiator hoses. If oil cooler is installed, disconnect oil cooler lines from both cooler and engine. Remove radiator mounting screws and remove radiator.

2) Remove generator or alternator, unscrew fan and pulley retaining screws and remove fan and pulley. Remove water pump retaining bolts and remove pump. To install, reverse removal procedure.

### TIGHTENING SPECIFICATIONS

Application	Specification
Main Bearing Nuts.....	70 (9.6)
Flywheel Set Screws.....	40 (5.5)
Connecting Rod Bolts.....	35-40 (4.8-5.5)
Rocker Bracket Nuts.....	25 (3.5)
Oil Pump-to-Crankcase.....	14 (2.0)
Oil Pan Bolts.....	6 (.83)
Side Covers.....	2 (.28)
Timing Cover	
1/4" Screws.....	8 (.83)
5/16" Screws.....	14 (2.0)
Rear Plate	
5/16" Screws.....	20 (2.8)
3/8" Screws.....	30 (4.2)
Water Pump.....	17 (2.4)
Thermostat Housing.....	8 (1.1)
Rocker Cover Nuts.....	4 (.55)
Manifold Nuts.....	15 (2.1)
Clutch-to-Flywheel.....	25-30 (3.5-4.2)
Carburetor Stud Nuts.....	2 (.28)