

Mercedes-Benz Engines

4.5 LITER V8

GENERAL SPECIFICATIONS										
Year	Displ.		Carburetor	HP at RPM	Torque (Ft. Lbs. at RPM)	Compr. Ratio	Bore		Stroke	
	cu. ins.	cc					in.	mm	in.	mm
1975	275.8	4520	Fuel Inj.	180@4750	220@3000	8.0-1	3.62	92	3.35	85

ENGINE IDENTIFICATION

Identification number is located on tag attached to engine crankcase. First six digits of code are used to identify engine, as follows:

Application	Chassis Type	Engine Number
450SE	116.032	117.983
450SEL	116.033	117.983
450SL	107.044	117.982
450SLC	107.024	117.982

ENGINE REMOVAL

Removal - 1) Disconnect all necessary water hoses, electrical leads (both battery cables), fuel lines, vacuum lines and fuel injection linkage. Remove fan, radiator and air cleaner.

2) Drain power steering reservoir and disconnect hoses. Unbolt air conditioning compressor and position hoses and compressor out of way. *NOTE - It is not necessary to discharge the air conditioning system during engine removal if compressor can be moved aside enough to permit engine clearance.*

3) Disconnect fuel injection heating connections, oil pressure gauge, and ground strap. Remove left engine shock mount and loosen right side mount. Disconnect upper left side mount and right side mount from suspension. Disconnect and lower the exhaust system. Disconnect torsion bar and hand brake.

4) Remove tunnel shield and disconnect drive shaft at center bearing. Using suitable jack, support transmission. Remove engine carrier, marking it for reinstallation. Disconnect all linkage extending from transmission. On standard transmission, disconnect hydraulic lines. Attach suitable hoist, remove engine mounting bolts and lift engine from vehicle.

INTAKE MANIFOLD REMOVAL

Drain cooling system and remove air cleaner. Disconnect fuel injection linkage and fuel lines on pressure regulator. Disconnect fuel start valve. Remove ignition valves. Extract in-

take manifold bolts and lift manifold off in rearward direction. To install, reverse removal procedure.

CYLINDER HEAD REMOVAL

1) Drain cooling system and crankcase. Remove air cleaner and battery. Disconnect cable set for electronic ignition system and fuel injection linkage. Loosen ring line with injection valves and remove.

2) Disconnect and remove intake pipe (manifold). If equipped with automatic transmission, remove fluid filler pipe from its attachment to cylinder head. Remove alternator and bracket. Remove oil pump (high pressure) carrier and distributor.

3) Disconnect exhaust system. Drain power steering reservoir and disconnect both hoses. Remove chain tensioner and valve covers. Mark camshaft gear and chain for reinstallation. Remove upper chain dampers (side rails). Withdraw bolts and remove cylinder head. *NOTE - Bottom row of camshaft bearing bolts also secure cylinder head. Care must be exercised when removing right side cylinder head as chain may not clear.* To install, reverse removal procedure.

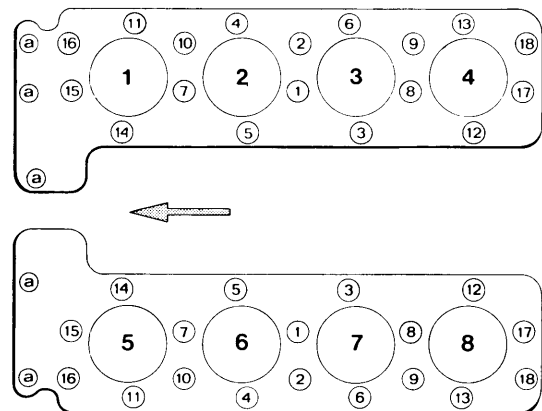

Fig. 1 Cylinder Head Tightening Sequence

VALVES							
Engine & Valve	Head Diam.	Face Angle	Seat Angle	Seat Width	Stem Diameter	Stem Clearance	Valve Lift
4520 cc Int.	1.7362-1.7440 (44.10-44.30)	45°	45°	.051-.078 (1.3-2.0)	.3492-.3498 (8.96-8.97)	
Exh.	1.4547-1.665 (36.95-37.25)	45°	45°	.059-.079 (1.5-2.0)	.4303-.4311 (10.93-10.95)	

4.5 LITER V8 (Cont.)

VALVE ARRANGEMENT

Right Bank – E-I-E-I-E-I-E (front to rear).

Left Bank – E-I-I-E-I-E-I-E (front to rear).

VALVE GUIDE SERVICING

1) With cylinder head removed and suitably supported, clean bores of valve guides. Hard oil carbon deposits can be eliminated with a honing needle.

2) Using a suitable plug gauge, inspect valve guide. If guide is beyond tolerance, replace.

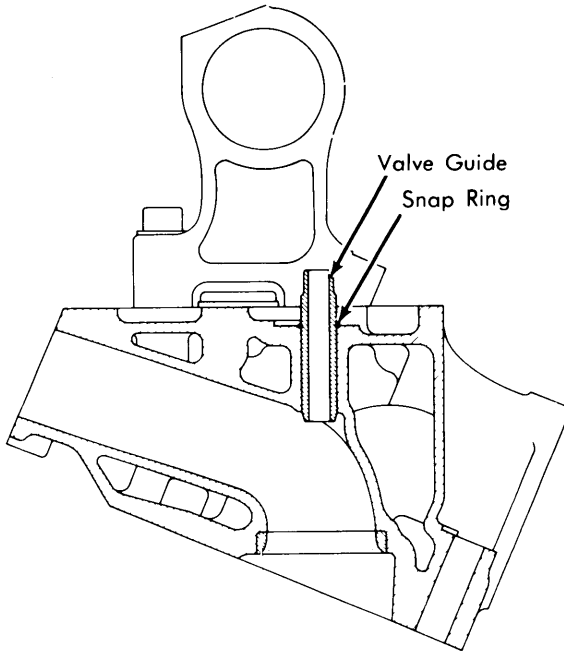

Fig. 2 Replacement of Valve Guides

3) With suitable remover/installer mandrel, drive worn guide from its position. Inspect valve guide bore (in cylinder head) and ream to accept ensuing oversize.

4) Heat cylinder head to approximately 194°F and cool valve guides (if possible). Coat valve guide bore with oil and, using remover installer mandrel, seat new valve guide. **NOTE** – Ensure circlip is properly installed. Recheck bore of valve guide and equalize any high spots.

VALVE STEM SEALS

1) Remove rocker arm. Bring piston of respective cylinder to TDC and support valve. **NOTE** – Valves must not seat on piston crown, because inclined arrangement of valves in relation to piston will bend valves.

2) With hammer, strike valve spring retainer to loosen cone halves. Use suitable remover/replacer tool and push valve spring retainer downward until cones can be removed. Remove valve spring retainer, valve springs, and valve stem seals.

3) To install, lubricate valve stem seal. Place assembly sleeve on inlet valve. Slide on seal with assembly mandrel (see illustration). To complete installation, reverse removal procedure.

VALVE SPRINGS			
Engine	Free Length In. (mm)	PRESSURE Lbs. @ In. (kg @ mm)	
		Valve Closed	Valve Open
4520 cc	Inner	1.3@24.7 (33@11.2)	.846@50.7 (21.5@23)
	Outer	2.01 (51)	1.2@189.6 (30.5@86)

VALVE SEAT RING

1) If valve seat is worn, carefully remove seat using suitable tool (000 589 17 69 00). Check valve guide prior to removing seat. See Valve Guide Servicing. Do not completely remove seat with tool; leave approximately .012-.016" (.3-.4 mm). Extract remainder with screwdriver or scribe.

2) Thoroughly clean receiving bore and check diameter; it should be 1.811-1.812" (46.0-46.02 mm) for both intake and exhaust.

3) To install, heat cylinder head to approximately 140°F (60°C) and place seat ring into bore. Position seat by lightly tapping with suitable mandrel and hammer. After ring is installed, peen-lock it at three points.

ROCKER ARM ASSEMBLY

1) Remove valve covers and from valve adjuster remove tensioning spring. A screwdriver should be only tool necessary.

NOTE – For cranking engine, do not use camshaft nut.

2) Position suitable remover/replacer tool against camshaft and on valve spring retainer. Push valve downward to relieve rocker arm (rocker arm should not be under a load). Before removing arm mark for reinstallation.

3) To install, reverse removal procedure. **NOTE** – Check valve clearance.

VALVE ADJUSTMENT

Adjust valves with engine cold. Set camshaft lobes of corresponding valve in such a manner that tip of lobe does not push rocker. Valve clearance is measured between side of rocker arm and basic cam circle. Measure valve clearance by inserting tolerance strip for intake and exhaust valves. If adjustment is necessary, turn screw, using suitable tool. Clearance is correct when light resistance felt removing tolerance strip.

Valve Clearance Adjustment

Application	Intake	Exhaust
All Models	.003" (.08 mm)	.008" (.20 mm)

Mercedes-Benz Engines

4.5 LITER V8 (Cont.)

PISTONS, PINS, RINGS						
Engine	PISTONS	PINS		RINGS		
	Clearance In. (mm)	Piston Fit In. (mm)	Rod Fit In. (mm)	Rings	End Gap In. (mm)	Side Clearance In. (mm)
4520 cc	.003 (.02-.03)0002-.0007 (.005-.018)	No. 1	.014-.022 (.35-.55)	.002-.003 (.050-.082)
				No. 2	.014-.022 (.35-.55)	.0016-.003 (.040-.072)
				Oil	.010-.016 (.25-.40)	.0016-.003 (.040-.072)

OIL PAN REMOVAL

1) Drain crankcase and disconnect transmission oil cooler (if equipped). Remove air cleaner. Disconnect front torsion bar.

2) Disconnect oil damper and place out of way. Remove oil dipstick. Raise front of vehicle and remove cover plate on intermediate flange.

3) On all models equipped with air conditioning, detach coolant compressor and place out of way. **NOTE** - Do not disconnect coolant lines under pressure. Loosen oil pan mounting bolts. For access to bolts behind damper align recess. Carefully lower oil pan.

CRANKSHAFT MAIN & CONNECTING ROD BEARINGS							
Engine	MAIN BEARINGS				CONNECTING ROD BEARINGS		
	Journal Diam. In. (mm)	Clearance In. (mm)	Thrust Bearing	Crankshaft End Play In. (mm)	Journal Diam. In. (mm)	Clearance In. (mm)	Side Play In. (mm)
4520 cc	2.517-2.518 (63.93-63.96)	.0014-.003 (.035-.075)004-.009 (.10-.23)	2.045 50.05	.001-.003 (.035-.065)	.009-.015 (.22-.38)

MAIN & CONNECTING ROD SERVICE

1) Mount main bearing cap to cylinder block and attempt to obtain same absolute value at three different points (see illustration). Ensure cap is correctly positioned when taking reading.

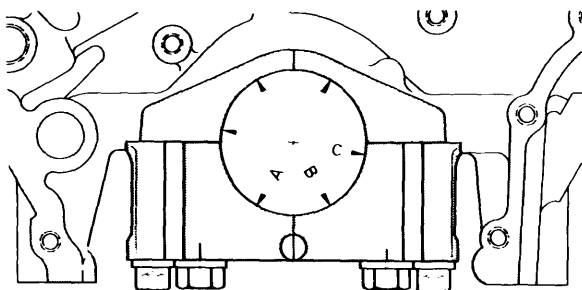

Fig. 3 Locations for Measuring Bore Diameter

2) If basic bore diameter is worn, causing excessive clearance, remove a maximum of .008" (.02 mm) from contact surface of bearing cap and install undersize bearing. **NOTE** - It is imperative that taper of bearing caps is not more than .004" (0.1 mm).

3) Bearings are available in two groups of varying thicknesses, and are to be used according to bearing basic

bore. If basic bore is 0-.0004" (0-.01 mm), use a blue color-coded bearing; if bore is .0004-.0008" (.01-.02 mm), use a red color-coded bearing.

4) Remove bearing cap and thoroughly clean both cap and bearing. To install, place in position and tighten to specification.

5) Holding connecting rod in a suitable vise, use above procedure to inspect connecting rod bearings.

6) With crankshaft installed, inspect end play by shifting in a fore and aft motion.

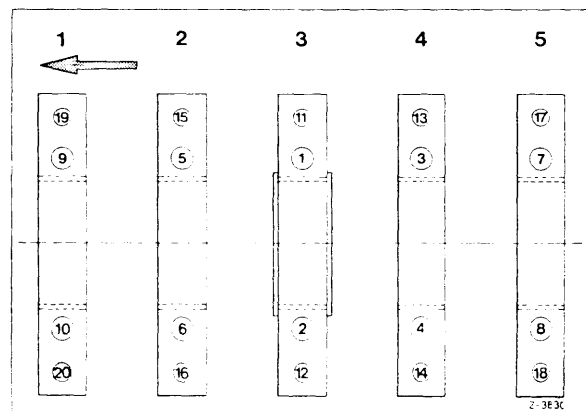

Fig. 4 Crankshaft Main Bearing Tightening Sequence

4.5 LITER V8 (Cont.)

REAR CRANKSHAFT SEALING RING

- 1) Remove air cleaner on automatic transmission models only. Disconnect control pressure linkage to transmission. Drain transmission. Disconnect rear torsion bar from mount. **NOTE** – Level control rod must be disconnected from valve.
- 2) Disconnect handbrake linkage. Disconnect from transmission, linkage, vacuum line, speedometer cable and oil filler tube.
- 3) On manual transmission models only, disconnect hydraulic line and plug openings. Disconnect transmission bell housing and starter, placing it out of way.
- 4) Remove engine mounts and crossmember after suitably supporting engine. Engine must not tilt downward. Lift out transmission.
- 5) Remove driven plate or flywheel and intermediate flange. Using two screwdrivers, remove cover and force sealing ring out of cover. To install, use a suitable tool and insert sealing ring. Coat cover with appropriate sealing compound. Reverse removal procedure to install remaining components.

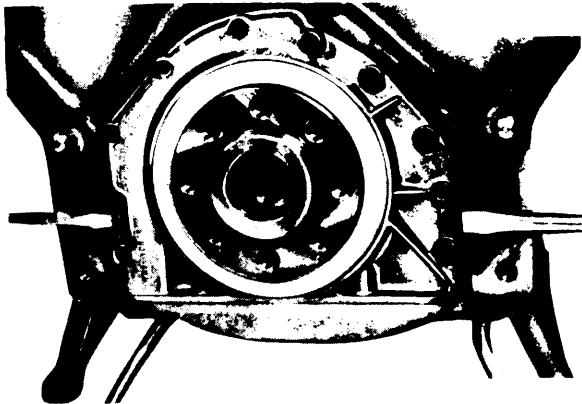

Fig. 5 Removing Sealing Ring

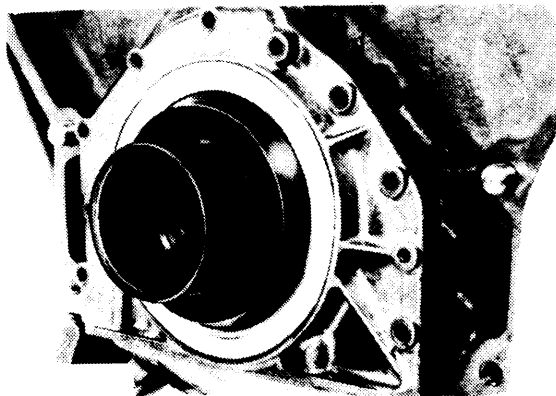

Fig. 6 Seating Sealing Ring

CAMSHAFT			
Engine	Journal Diam. In. (mm)	Clearance In. (mm)	Lobe Lift In. (mm)
4520 cc0010-.0022 (.025-.057)

CAMSHAFT REMOVAL

- 1) Remove air cleaner, venturi control valve unit and disconnect vacuum hose to brake unit. Remove valve covers. Remove both camshaft sprocket bolts, spark plugs and valve clamp springs (see illustration). Extract rocker arms and mark for reinstallation.

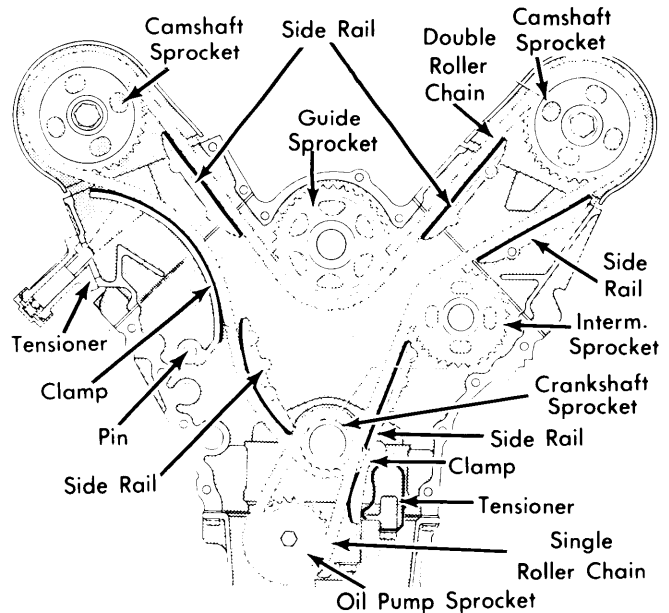

Fig. 7 Timing Chains & Sprockets

NOTE – Both camshafts should not be removed at same time.

- 2) Place No. 1 cylinder at TDC. Ensure timing pointer is at TDC and markings on both compensating washers of camshaft are in alignment with markings on front camshaft bearings.

CAUTION – Make sure rear cam bearing has an oiling hole and has not been replaced with a plain bearing.

- 3) Connect timing chain and camshaft sprocket with wire so chain does not fall or skip. Drive cam sprocket from camshaft. Remove bearing bracket bolts and lift camshaft off with brackets.

- 4) To install, lubricate new camshaft and insert into bearing brackets. Position assembly into cylinder head and tighten as required. **NOTE** – If external lubrication pipe has been removed, replace plastic connectors. Reverse removal procedure for remaining components.

4.5 LITER V8 (Cont.)

DISTRIBUTOR DRIVE GEAR

1) With timing and crankshaft chains exposed, disconnect all chain dampers (side rails) and timing chain tensioner. Remove chain from intermediate gear. Pull gear forward and remove from bearing in cylinder crankcase by twisting. Remove in an upward direction.

2) To install, reverse removal procedure. **NOTE** — When reinstalling chain, ensure hex bolts on camshaft gears are not loosened.

CHAIN TENSIONER

NOTE — In all instances chain tensioner is lubricated and connected to oiling circuit.

450SL & 450SLC — Remove right side valve cover. Extract both mounting bolts and remove chain tensioner. Cable bracket must be held aside.

450SE & 450SEL — Disconnect battery, remove right side valve cover and alternator. Unbolt bracket for right side engine damper from frame. Remove chain tensioner.

① VALVE TIMING				
Engine	INTAKE		EXHAUST	
	Open (BTDC)	Close (ALDC)	Open (BLDC)	Close (ATDC)
4520 cc	5°	21°	25°	5°

① — After 12,000 miles.

VALVE TIMING

NOTE — Measurements must be made with valve clearance set at zero and with .015" (.38 mm) valve lift.

1) After removing tensioning springs, push valve down using suitable rocker arm installer/remover. Insert a valve gauge between cam and rocker arm.

2) Attach a dial indicator gauge so that pointer of gauge rests on retainer of intake valve, preloaded to .079" (2.007 mm). Turn dial back to zero.

3) Turn engine and read dial when gauge reaches 60. Readings should correspond to those found in Valve Timing Chart.

4) If timing requires correction, an offset Woodruff key or new chain must be installed. Keys are available in four offsets.

ENGINE OILING

ENGINE OILING SYSTEM

Lubrication is provided by a gear type oil pump directly driven by crankshaft. Oil is picked up through a strainer from lower portion of oil pan and forced to oil filter through a duct in timing casing. After passing through filter, oil flows to center main duct, to crankshaft and through rod bearings up rods to piston pin bushing. Oil galleries run to cylinder head, valve assemblies and to camshafts. Circuit also includes chain tensioner, ignition and, if applicable, air compressor.

Oil Filter — Disposable cartridge type. Located near front of engine.

Normal Oil Pressure — 7.1 psi@idle; 42.6 psi@3000 RPM.

Over Flow Valve — Valve is located in crankcase and enters into main oil gallery. When filter becomes severely contaminated valve will open and oil will enter in an unfiltered state.

Crankcase Capacity — 8.0 quarts.

ENGINE COOLING

WATER PUMP

Disconnect all necessary water hoses and any remaining components from water pump housing. Remove distributor and all mounting bolts. Remove pump from vehicle. To install, reverse removal procedure.

Thermostat — Located in water pump housing, as shown in illustration. To remove drain cooling system, remove air cleaner, disconnect battery and alternator. Remove housing and ther-

mostat. When installing ensure ball valve is mounted at highest point.

Cooling System Capacity — 15.8 quarts.

Thermostat — Opens at 167°F (75°C).

Radiator Cap — 13-15 psi.

4.5 LITER V8 (Cont.)

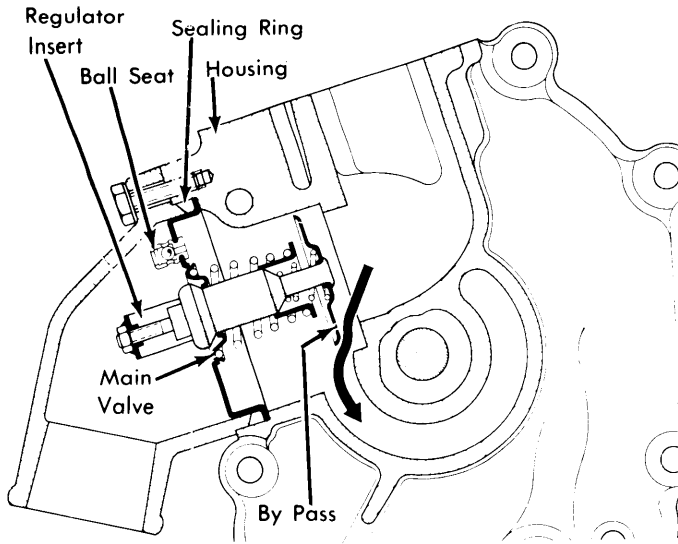

Fig. 8 Water Pump Assembly

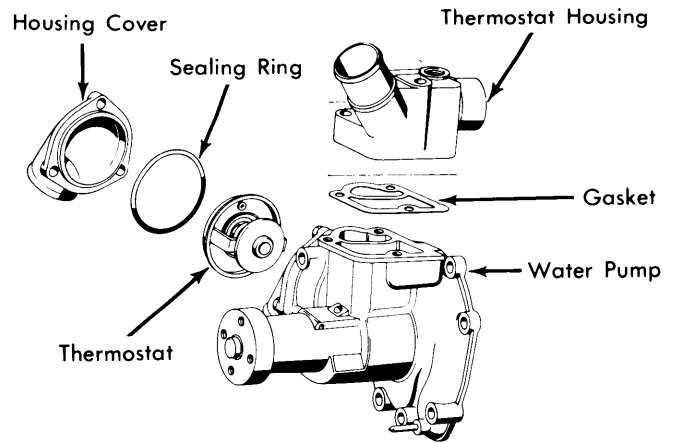

Fig. 9 Thermostat Assembly Exploded View

TIGHTENING SPECIFICATIONS

Application	Ft. Lbs. (mkg)
Cylinder Head Bolts	
Cold	36 (5)
Warm	43 (6)
Rocker Cover	11 (1.5)
Camshaft Bearing Bracket Bolts	36 (5)
Camshaft Sprocket	72 (10)
Injection Nozzle-to-Injection Valve	7 (1)
Connecting Rod Bolts	33 (4.5)
Main Bearing Caps	
Large Bolt	72 (10)
Small Bolt	47 (6.5)
Crankshaft Bolt	195-239 (27-33)
Oil Pan	8 (1.1)
Oil Filter-to-Case	29 (4)
Oil Drain Plug	22 (3)
Oil Pressure Relief Valve	29 (4)