

300D DIESEL 5 CYLINDER

GENERAL SPECIFICATIONS										
Year	Displ.		Carburetor	HP at RPM	Torque (Ft. Lbs. at RPM)	Compr. Ratio	Bore		Stroke	
	cu. ins.	cc					in.	mm	in.	mm
1975	183.4	3005	Fuel Inj.	Ⓢ80@4000	126@2400	21.0-1	3.58	91	3.64	92.4

Ⓢ — DIN horsepower

ENGINE IDENTIFICATION

Engine identification number is stamped on left side of cylinder block. First six digits of this number are used for engine identification purposes.

Application	Chassis Type	Engine Number
300D.....	115.114.....	617.910

NOTE — If vehicle is equipped with air conditioning, it is not necessary to disconnect refrigerant hoses. Only detach compressor from its mounting and position compressor and hoses out of way.

ENGINE REMOVAL

Removal — 1) Remove hood and disconnect battery ground cable. Drain cooling system, remove radiator guard, radiator and disconnect heating hoses. On Auto. Trans. models, disconnect and plug oil cooler lines from transmission.

2) Remove air intake silencer. Disconnect fuel hoses and vacuum hose to power brake. On models with power steering and level control, disconnect and plug oil lines.

3) Disconnect oil pressure gauge hose. Disconnect idle control cable and stop-start cable. Remove accelerator linkage.

4) Disconnect ground cable from engine to chassis and all other electrical leads. Disconnect gearshift linkage and exhaust pipe at manifold.

5) Loosen steering relay arm and move downward together with center tie rod and steering shock absorber. Disconnect hydraulic line from clutch slave cylinder.

6) On Auto. Trans. models, disconnect oil cooler lines between transmission and oil cooler.

7) Disconnect exhaust pipe support bracket at transmission, loosen clamp on exhaust pipe and push downward.

8) Attach suitable lifting sling to engine. Mark position of rear engine crossmember in relation to chassis base panel, disconnect rubber mount at transmission and remove crossmember.

9) Disconnect speedometer cable. Disconnect propeller shaft and shaft plate from transmission. Push propeller shaft to rear after loosening clamping nut.

10) Disconnect plug from automatic transmission.

11) Remove bolts at both front engine mounts. Remove front limit stop. Loosen one screw and move power steering reservoir to one side.

12) Lift out engine at a 45° angle. To install, reverse removal procedures.

INTAKE & EXHAUST MANIFOLD REMOVAL

Intake Manifold — Remove air cleaner. Disconnect throttle linkage and bowden cable for idling control on throttle duct.

Unscrew vacuum line. Remove attaching nuts and intake manifold from cylinder head.

Exhaust Manifold — Disconnect exhaust pipe from manifold. Remove attaching nuts and lift off exhaust manifold.

CYLINDER HEAD REMOVAL

Removal — 1) Drain cooling system. Disconnect all water hoses attached to cylinder head. Remove vent line, air cleaner and rocker cover.

2) Disconnect vacuum line, injection lines and leakage oil line. Loosen fuel filter screws and move filter out of the way. Remove exhaust pipe from manifold.

3) Disconnect cable to glow plugs and heat sensor from water thermometer. Rotate engine until there is no load on rocker arms and remove rocker arm assembly.

4) Remove top chain guide. Unscrew camshaft sprocket screw. Remove chain tensioner and camshaft sprocket.

5) Loosen and remove head bolts, working from outside toward inside of head. Remove four socket screws at front of head. Lift off head and gasket.

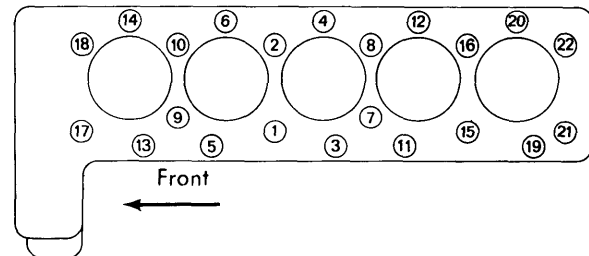

Fig. 1 Cylinder Head Tightening Sequence

Installation — 1) Rotate engine until No. 1 piston is at TDC of compression stroke. Install head gasket and cylinder head, torque head bolts to specifications (see illustration).

2) Install four socket screws in front of head. Connect ground lead for glow plugs to screw under main fuel filter. Insert Woodruff key in camshaft. Place shim on camshaft so mark aligns with mark of first camshaft bearing support.

3) Install camshaft sprocket and chain with tension on driving side of chain, using care not to move camshaft or crankshaft.

4) Check endplay of camshaft. See *Camshaft Bearing Replacement*. Install upper chain guide. Using a new seal, install chain tensioner filled with oil.

5) Install rocker arm assembly, rotating camshaft so there is no load on rocker arms while tightening. Adjust tappets with engine cold. See *Valve Clearance Adjustment*.

6) Reinstall remaining components in reverse of removal. Run engine until it has reached 176°F and retighten head bolts, recheck tappet clearance. Drive vehicle 180-600 miles and retorquing head bolts. Loosen each head bolt slightly, a bolt at a time, when retorquing head bolts.

300D DIESEL 5 CYLINDER (Cont.)

VALVES							
Engine & Valve	Head Diam. In. (mm)	Face Angle	Seat Angle	Seat Width In. (mm)	Stem Diameter In. (mm)	Stem Clearance In. (mm)	Valve Lift In. (mm)
3005 cc Intake	1.563-1.571 (39.70-39.90)	30°	30°	.051-.063 (1.3-1.6)	.3906-.3913 (9.92-9.94)	.0030 (.075)
Exhaust	1.343-1.350 (34.10-34.30)	30°	30°	.098-.114 (2.5-2.9)	.3906-.3913 (9.92-9.94)	.0030 (.075)

VALVE ARRANGEMENT

E-I-I-E-E-I-I-E-E-I (front to rear).

VALVE GUIDE SERVICING

- 1) Check valve guide bores and ensure they are not less than .3937" (10.00 mm) or larger than .3947" (10.025 mm). Remove all carbon before measuring guides.
- 2) Using a suitable drift, drive intake guide out toward top of head and exhaust guide toward combustion chamber.
- 3) Press in new guides from combustion side until specified distance is achieved (see illustration). Check guide bores and remove any tight spots.

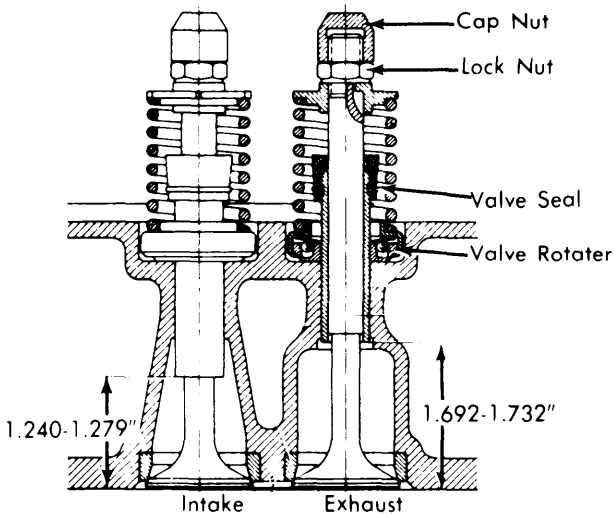

Fig. 2 Installed View of Valve Assemblies

- 4) Valve guides are available in standard and one oversize (coded red). An interference fit of .0004-.0015" (.010-.040 mm) is used. If guide does not meet specifications, install oversize part. Note that intake guides are 2.40" (60.96 mm) long and exhaust guides are 1.95" (49.53 mm) long.

Valve Guide Specification

Application	Guide O.D. In. (mm)	Cyl. Head Bore In. (mm)
Standard	.5522-.5527 (14.03-14.04)	.5511-.5518 (14.00-14.02)
Oversize (Red)	.5601-.5605 (14.23-14.24)	.5590-.5597 (14.20-14.22)

VALVE STEM OIL SEALS

- 1) Using a spring compressor, unscrew cap nut and lock nut from valve stem. Remove valve collar and spring.
- 2) Prepare a tool for removing oil seal (see illustration). Using oil seal tool, lever oil seal off of guide and stem.

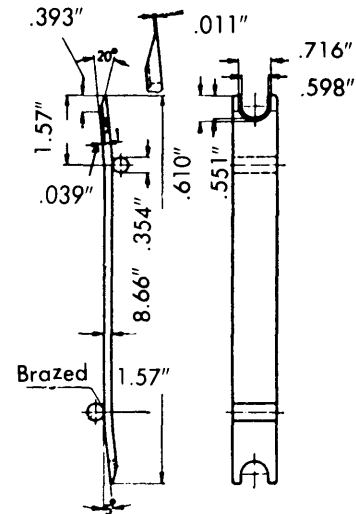

Fig. 3 Valve Stem Oil Seal Tool

- 3) Place plastic sleeve over threaded end of valve stem. Slide new oil seal in place, using oil seal tool. Install spring and collar. Screw lock nut and cap nut on end of valve stem.

VALVE SPRINGS

Engine	Free Length In. (mm)	PRESSURE Lbs. @ In. (kg @ mm)	
		Valve Closed	Valve Open
3005 cc	1.988 (50.5)	58.2@1.512 (26.4@38.41)	116.8@1.177 (53.0@29.9)

VALVE SPRING REMOVAL

Remove rocker arms. Using a spring compressor, unscrew cap nut and lock nut. Remove valve spring collar and lift out spring. Check spring for wear or fatigue, replace as necessary. To install, reverse removal procedures with close wound coils next to cylinder head.

ROCKER ARM ASSEMBLY

- 1) Remove air cleaner and tappet cover. Loosen rocker arm bracket bolts, rotate camshaft so there is no load on rocker arms being removed.

Mercedes-Benz Engines

300D DIESEL 5 CYLINDER (Cont.)

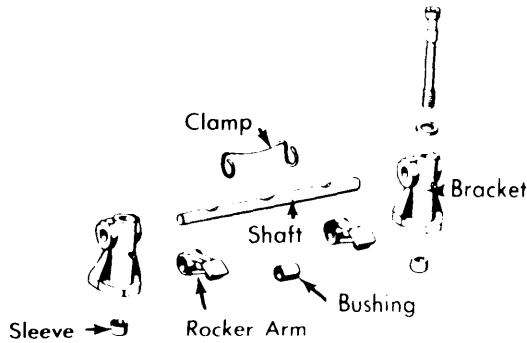

Fig. 4 Detail of Rocker Arm Assembly

2) Slide rocker arm brackets, rocker arms tightening clamp and spacer off of shaft. Inspect all parts for wear. Replace shaft, rocker bushing or rocker bracket if necessary. To install, reverse removal procedures.

VALVE CLEARANCE ADJUSTMENT

Adjust valves according to firing sequence (1-2-4-5-3). Rotate crankshaft until piston of valves to be adjusted is at TDC of compression stroke. Measure clearance between heel of cam and rocker arm. Set clearance to .012" (.30 mm) with engine cold and to .014" (.35 mm) with engine warm.

PISTONS, PINS, RINGS						
Engine	PISTONS		PINS		RINGS	
	Clearance In. (mm)	Piston Fit In. (mm)	Rod Fit In. (mm)	Rings	End Gap In. (mm)	Side Clearance In. (mm)
3005 cc	.0008-.0012 (.02-.03)	⓪	Push Fit	No. 1	.0118-.0177 (.30-.45)	.0035-.0048 (.090-.122)
				No. 2	.0118-.0177 (.30-.45)	.0031-.0044 (.080-.112)
				No. 3	.0098-.0157 (.25-.40)	.0008-.0020 (.020-.052)

⓪ — Interference fit. See Piston & Rod Assembly in this article.

OIL PAN REMOVAL

1) Remove oil pan cover, if equipped. Drain engine oil. Remove dipstick and tube. Detach cover plate from clutch housing. Remove oil pan bolts.

2) Loosen steering shock absorber and drag link and turn to one side. Unscrew drag link on intermediate steering and turn aside. Remove oil pan.

PISTON & ROD ASSEMBLY

Removal — 1) Remove cylinder head and oil pan. Unscrew connecting rod nuts. Tap rod bolts with a plastic mallet to loosen rod on crankshaft. Push piston and connecting rod assembly out top of cylinder block.

2) Remove piston pin circlips. Heat piston to 104-140° (40-60°C) and press out piston pins.

Installation — 1) Heat piston and reinstall wrist pin and circlips. Piston and wrist pin must be matched.

2) Install connecting rod and cap so cylinder numbers face left side of engine and arrow on piston crown faces forward.

NOTE — Piston must be installed facing proper direction or damage to the engine will occur.

3) Connecting rod bolts are of a special design, having an expansion shank which is used to measure bolt stress. If, after several tightenings, the expansion section of the bolt has reached a minimum diameter of .2834" (7.2 mm), the bolt must be replaced. When new, this shank portion should be .3307" (8.4 mm). When replacing, drive out old bolts and insert new ones into same spline pattern in rod cap. **NOTE** — First tightening of NEW bolts is to 50.6 ft. lbs. (7.0 mkg); subsequent tightenings should be to 36 ft. lbs. (5.0 mkg).

4) Rotate crankshaft until piston to be measured is at TDC. Measure distance from top of cylinder block to piston crown. Piston must not protrude more than .024-.043" (.61-1.1 mm) above block surface.

FITTING PISTONS

Measure piston and cylinder diameters to determine running clearance. Piston diameter is measured at 90° to piston pin bore near bottom of piston skirt. There are three compression rings and one oil ring. Install compression rings with marking "top" or "F" and oil ring with marking "GOE" or "F" facing upward. Install rings on piston in the following manner:

Piston Ring Location

Double Taper Ring (Molybdenum).....Top Groove
 Rectangular Ring (Inside Chamfer Upward)..... 2nd Groove
 Rectangular Ring (Stepped Downward)..... 3rd Groove
 Chamfered Oil Ring with Hose Expander..... 4th Groove

CRANKSHAFT MAIN & CONNECTING ROD BEARINGS							
Engine	MAIN BEARINGS				CONNECTING ROD BEARINGS		
	Journal Diam. In. (mm)	Clearance In. (mm)	Thrust Bearing	Crankshaft End Play In. (mm)	Journal Diam. In. (mm)	Clearance In. (mm)	Side Play In. (mm)
3005 cc	2.7541-2.7545 (69.95-69.96)	.0014-.003 (.035-.075)	No. 3	.0039-.009 (.10-.24)	2.0454-2.0458 (51.95-51.96)	.0012-.0028 (.030-.070)	.005-.010 (.12-.25)

300D DIESEL 5 CYLINDER (Cont.)

MAIN BEARING SERVICE

Measure main bearing and connecting rod journals for out-of-round and taper. Out-of-round must not exceed .0002-.0004" (.005-.010 mm) and taper must not exceed .0004-.0006" (.010-.015 mm). Select proper undersize, if required, and grind crankshaft to following diameters:

Crankshaft Journal Diameters

Application	Main In. (mm)	Con. Rod In. (mm)
Standard	2.7541-2.7545 (69.95-69.96)	2.0454-2.0458 (51.95-51.96)
1st Undersize	2.7442-2.7446 (69.70-69.71)	2.0356-2.0360 (51.70-51.71)
2nd Undersize	2.7344-2.7348 (69.45-69.46)	2.0257-2.0261 (51.45-51.46)
3rd Undersize	2.7246-2.7249 (69.20-69.21)	2.0159-2.0163 (51.20-51.21)
4th Undersize	2.7147-2.7151 (68.95-68.96)	2.0060-2.0064 (50.95-50.96)

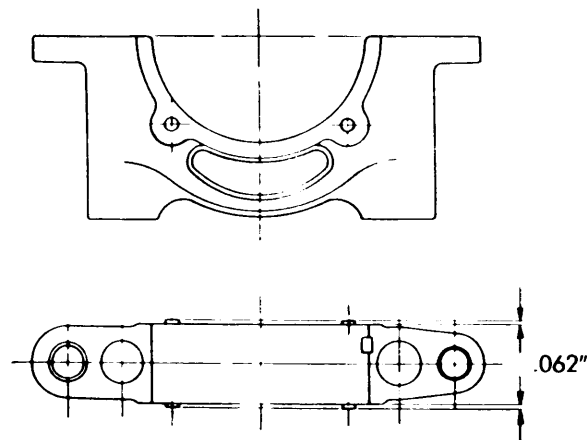

Fig. 5 Detail of Third Main Bearing Cap

THRUST BEARING ALIGNMENT

Third main bearing cap has pin located thrust washers to adjust crankshaft end play. Measure end play and install thrust washer(s) required to give proper end play. Measure pin protrusion from main bearing cap to ensure it does not exceed .062" (1.57 mm) as illustrated (See Fig. 5). Standard and oversize thrust washers are available in the following sizes:

Thrust Washer Thicknesses

Application	In. (mm)
Standard	.078 (1.98)
1st Oversize	.080 (2.03)
2nd Oversize	.082 (2.08)
3rd Oversize	.084 (2.13)
4th Oversize	.086 (2.18)
5th Oversize	.088 (2.23)
6th Oversize	.090 (2.28)
7th Oversize	.092 (2.33)

REAR MAIN BEARING OIL SEAL SERVICE

1) With oil pan and crankshaft removed, insert fabric oil seal in groove in crankcase behind rear main bearing. Cut seal at parting face so that it protrudes slightly above parting face.

2) Install other half in oil pan groove, using tallow on seal halves. Reinstall crankshaft and oil pan. Rotate crankshaft to check tightness of seal. If seal is too tight, remove oil pan and crankshaft and roll down high spots with a hammer handle.

FRONT OIL SEAL

Removal - 1) Remove attaching bolt and crankshaft pulley. Attach a suitable puller and remove counterweight. Remove oil pan.

2) Press out seal ring and remove spacer from crankshaft.

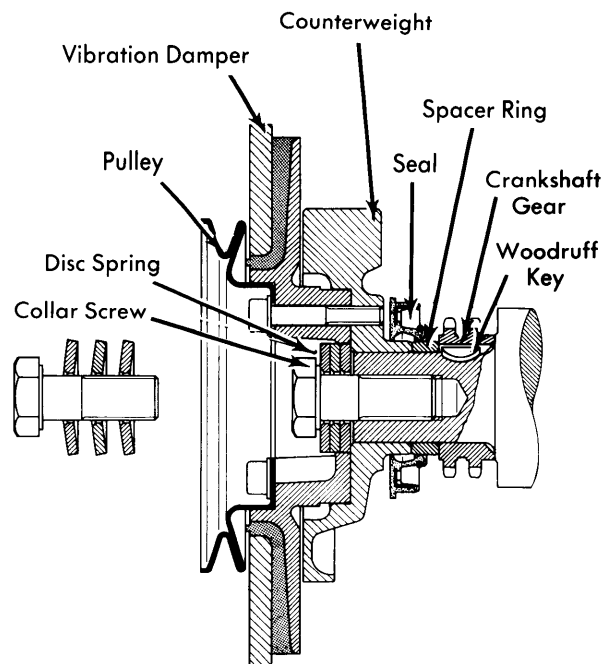

Fig. 6 Sectional View of Crankshaft Front Oil Seal

Installation - 1) Fill new seal between sealing lips with hot bearing grease and coat outer diameter with sealing compound.

2) Press seal in until it touches face of crankcase. Slide spacer ring onto crankshaft.

3) Replace oil pan. Install remaining components in reverse of removal procedures.

CAMSHAFT			
Engine	Journal Diam. In. (mm)	Clearance In. (mm)	Lobe Lift In. (mm)
3005 cc	No. 1	.0010-.0026 (.025-.066)
	No. 2 & 3	.0010-.0026 (.025-.066)

300D DIESEL 5 CYLINDER (Cont.)

CAMSHAFT REMOVAL

- 1) Remove camshaft sprocket and rocker arm assembly. Disconnect external camshaft oiling tube.
- 2) Remove camshaft bearing supports. Slide camshaft bearing supports off of camshaft. To install, reverse removal procedures.

CAMSHAFT BEARING REPLACEMENT

- 1) Inspect camshaft bearing journals for wear. If worn, grind bearing journals and fit undersize bearings.

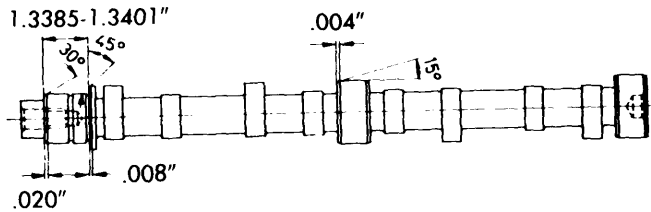

Fig. 7 Detail View of Camshaft

- 2) Bearing on No. 1 journal controls camshaft end play. Width of journal is 1.3385-1.3401" (34.0-34.03 mm). Place bearing on camshaft and install retaining ring. Using a feeler gauge, measure clearance between camshaft flange and bearing (see illustration). Lap bearing to proper fit. The following table lists camshaft bearing journal diameters for standard and undersize bearings:

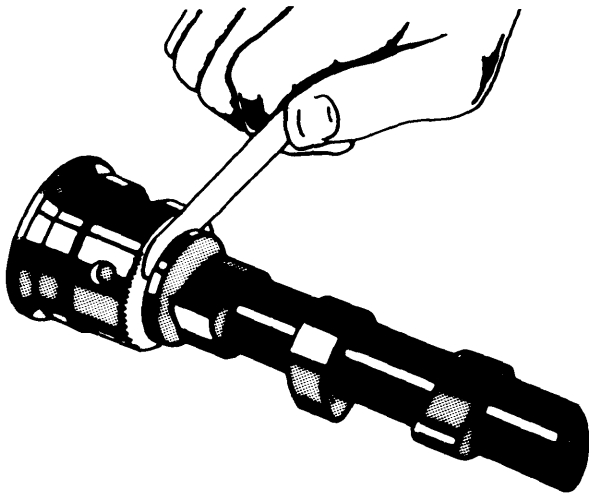

Fig. 8 Measuring Camshaft End Play

Camshaft Journal Diameters

Application	Journal No. 1 In. (mm)	Journal No. 2 & 3 In. (mm)
Standard	1.3763-1.3769 (34.96-34.97)	1.8290-1.8297 (46.46-46.47)
Intermediate (Grey)	1.3723-1.3730 (34.86-34.87)	1.8251-1.8257 (46.36-46.37)
1st Undersize (Red)	1.3664-1.3671 (34.71-34.72)	1.8192-1.8198 (46.21-46.22)

Engine	VALVE TIMING			
	INTAKE		EXHAUST	
	Open (ATDC)	Close (ALDC)	Open (BLDC)	Close (BTDC)
3005 cc	13.5°	15.5°	19°	17°

TIMING CHAIN REPLACEMENT

- 1) Remove rocker cover and glow plugs so that engine turns easily. Remove chain tensioner and rocker arm brackets.

NOTE — Removal of rocker arm brackets is not imperative, but is recommended in order to avoid damage to valves or pistons, if, while turning engine, chain jumps over camshaft sprocket.

- 2) Grind off pins on a link of old chain and remove link. Using a master link, connect new chain to old chain on driving side of old chain.

NOTE — Install master link facing camshaft side of chain with spring lock closed end facing direction of rotation (see illustration).

- 3) Slowly turn engine in direction of rotation, feeding new chain in and old chain out uniformly. After chain threading is complete join ends of new chain with master link and make sure spring lock closed end is facing direction of rotation. Check that valve timing is correct. See *Valve Timing*. Reverse removal procedures for remaining components.

VALVE TIMING

- 1) Rotate No. 1 piston to TDC of compression stroke. Align camshaft timing mark with mark on No. 1 camshaft bearing support bracket (see illustration). Install camshaft sprocket.

- 2) If correct valve timing is not achieved when camshaft sprocket is installed, offset Woodruff keys are available to make timing corrections, see following table:

Offset Woodruff Keys

Offset	Crankshaft Correction
.0275" (.7 mm)	4°
.0354" (.9 mm)	6 1/2°
.0433" (1.1 mm)	8°
.0511" (1.3 mm)	10°

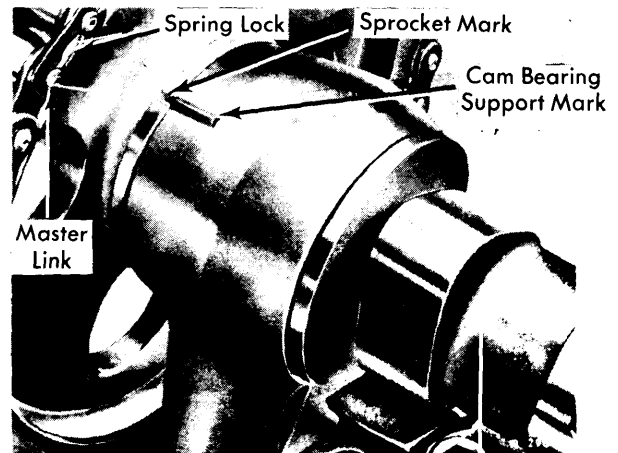

Fig. 9 Camshaft Timing Marks Location

300D DIESEL 5 CYLINDER (Cont.)

ENGINE OILING

ENGINE OILING SYSTEM

Engine lubrication is provided by a gear type oil pump, which force feeds oil through an oil filter to oil gallery. From oil gallery, oil flows to main and connecting rod bearings. Pistons, wrist pins and connecting rod bushings are splash lubricated. A vertical oil passage from oil gallery has a transverse passage which supplies oil to intermediate sprocket shaft and bearings. Another oil passage supplies oil to oil pump drive shaft and helical gear. Vertical passage also supplies oil to No. 1 camshaft bearing. An external oil tube attached to No. 1 camshaft bearing support lubricates other camshaft bearings and rocker arms.

Crankcase Capacity - 7.3 qts.

Oil Filter - Full-flow, clean main element 3,000 miles. Replace by-pass element 3,000 miles.

Normal Oil Pressure - 64-78 psi.

Pressure Regulator Valve - Non-adjustable.

OIL PUMP

Removal - Remove oil pan. Remove two attaching screws and lift out pump.

Disassembly - 1) Remove oil strainer. Unscrew lower pump body, and remove pump gears and shafts. Measure clearances between gear-to-body and gear-to-cover (see specifications).

2) If cast-in bushings in housing are worn, replace complete housing. Worn gears are replaced as an assembly. Assemble upper and lower housing without a gasket. Install strainer with a new gasket. Check that pump turns freely.

Installation - 1) Align drive shaft follower with helical gear and follower faces with respect to one another.

2) Insert oil pump with bracket and tighten mounting screws. Install oil pan.

Oil Pump Specifications

Application	In. (mm)
Gear-to-Body0009-.0022 (.023-.056)
Gear-to-Cover0018-.0029 (.046-.074)
Gear Backlash0019-.0059 (.048-.15)

ENGINE COOLING

WATER PUMP

Removal - 1) Drain cooling system below level of pump. Loosen hose clamps on top radiator hose. Remove radiator mounting bolts and push radiator forward.

2) Remove fan from drive pulley. Loosen nuts and adjusters on generator enough so fan belt may be removed. Unscrew and remove venting line between pump and cylinder head.

3) Water pump is a maintenance free type. When installing pump, check hub-to-flange and impeller-to-flange distance, (see illustration).

Thermostat - Opens at 176°F (80°C).

Cooling System Capacity - 11.1 qts.

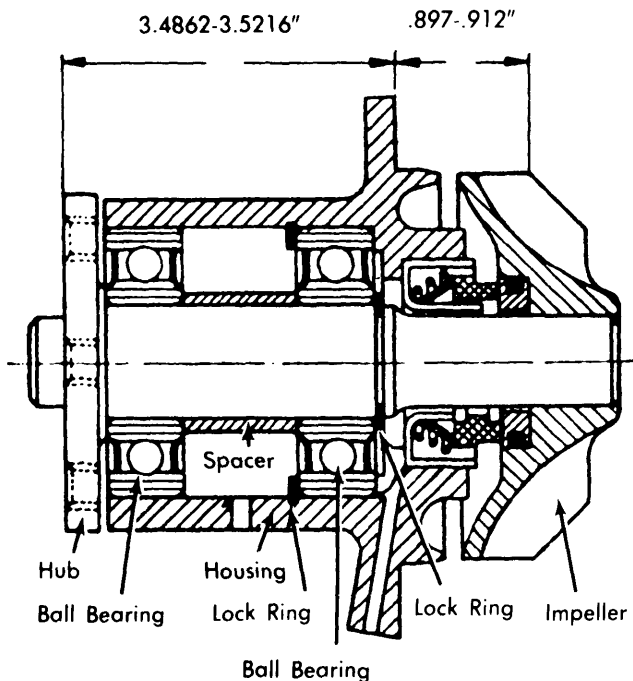

Fig. 10 Sectional View of Water Pump

TIGHTENING SPECIFICATIONS

Application	Ft. Lbs. (mkg)
Cylinder Head	
Step 1	29 (4)
Step 2	43 (6)
Step 3 [Ⓛ]	65 (9)
Camshaft Bearing Caps	18 (2.5)
Glow Plugs	36 (5)
Prechamber in Cyl. Head	108 (15)
Connecting Rod Caps	29-36 (4-5)
Main Bearing Caps	65 (9)
Crankshaft Front Hex Bolt	180 (25)
Oil Pan Bolts	8 (1.1)

Ⓛ - With engine warm.