

2800 CC V6

GENERAL SPECIFICATIONS										
Year	Displ.		Carburetor	HP at RPM	Torque (Ft. Lbs. at RPM)	Compr. Ratio	Bore		Stroke	
	cu. ins.	cc					in.	mm	in.	mm
1975	170	2800	2-Bbl.	8.2-1	3.66	92.964	2.79	70.866

ENGINE IDENTIFICATION

The second series of digits of vehicle identification plate, located on top of right front fender apron, indicates engine type.

Application

2800 cc..... PX

Engine Code

ENGINE REMOVAL

1) Disconnect battery cables. Disconnect all hoses and connections to air cleaner assembly while noting positions to aid in reassembly, then remove air cleaner assembly. Mark hood hinge locations, then remove hood. Raise vehicle on a hoist. Drain cooling system and crankcase.

2) Remove lower radiator hose and starter. Remove converter bolt access plug and three converter-to-flywheel bolts. Disconnect exhaust pipes from exhaust manifold. Remove converter housing-to-engine attaching bolts. Remove engine mount nuts.

3) Disconnect transmission cooler lines from radiator on models with automatic transmission. Disconnect and plug fuel lines at fuel pump. Loosen power steering pump idler, then remove power steering pump from bracket and position to one side. Disconnect oil pressure line and lower vehicle.

4) Remove downshift rod. Remove clutch linkage on models with manual transmission. Remove upper radiator hose, fan shroud, and radiator. Disconnect heater hoses at engine, remove hose retainer at rocker arm cover, and position hoses to one side.

5) Disconnect distributor vacuum line, connector and coil wire. Disconnect transmission vacuum line at intake manifold, and power brake vacuum hose. Disconnect accelerator cable retaining clip at ball stud, then pull lightly on cable while depressing tangs one at a time on bracket clip and remove throttle cable.

6) Disconnect rear ground wire and alternator connectors. Position a floor jack to support transmission. Attach lifting hoist to engine, and carefully lift engine from vehicle.

INTAKE MANIFOLD

Removal - 1) Remove air cleaner, disconnect battery negative cable, and throttle cables. Drain cooling system, disconnect hose from water outlet-to-radiator, and hoses and line from water outlet-to-water pump. Remove distributor cap and spark plug wires as an assembly.

2) Disconnect distributor wire and distributor vacuum line. Mark location of rotor and distributor housing, then remove distributor. Remove fuel line and filter between fuel pump and

carburetor, then remove rocker arm covers. Remove intake manifold nuts and bolts, then remove intake manifold assembly.

Installation - Apply sealing compound to joining surfaces and position gasket on block. Tab on right bank cylinder head gasket must fit into cutout of manifold gasket. Install sealing compound to retaining bolt bosses on intake manifold. Install manifold on cylinder block. Install bolts and nuts, then tighten in sequence as shown in illustration. Install remaining components in reverse of removal procedure.

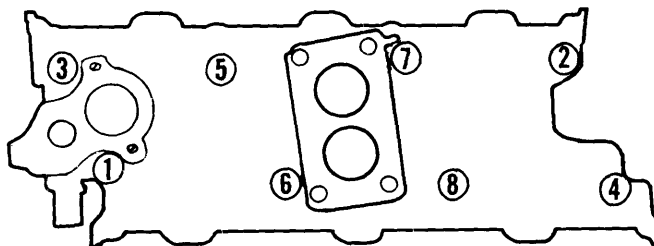

Fig. 1 Intake Manifold Tightening Sequence

CYLINDER HEAD

Removal - Remove intake manifold. Disconnect carburetor linkage and remove carburetor. Remove rocker arm shaft by loosening two bolts at a time. Remove oil baffles. Remove push rods while keeping in correct order for reinstallation into original position. Remove exhaust manifold. Remove cylinder head bolts and lift cylinder head from block.

Installation - Clean old gasket material from cylinder head and block. Install new cylinder head gaskets on block ensuring that "TOP" and "FRONT" markings on gasket are properly positioned. Position cylinder heads on block, install bolts and tighten in sequence as shown in illustration. Install remaining components in reverse of removal procedure.

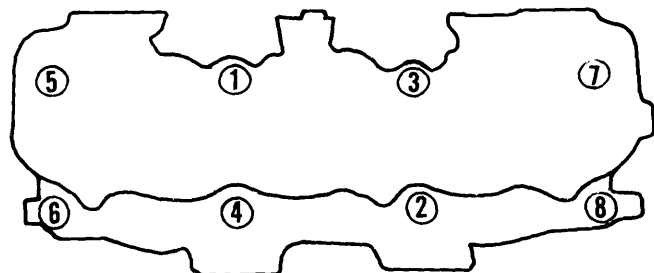

Fig. 2 Cylinder Head Tightening Sequence

2800 CC V6 (Cont.)

VALVES							
Engine & Valve	Head Diam. In. (mm)	Face Angle	Seat Angle	Seat Width In. (mm)	Stem Diameter In. (mm)	Stem Clearance In. (mm)	Valve Lift In. (mm)
2800 cc Intake	1.570 (39.88)	44°	45°	.050-.079 (1.3-2.0)	.3158-.3167 (8.02-8.04)	.0008-.0025 (.02-.06)	.373 (9.47)
Exhaust	1.269 (32.23)	44°	45°	.050-.079 (1.3-2.0)	.3149-.3156 (8.00-8.02)	.0018-.0035 (.046-.089)	.373 (9.47)

VALVE ARRANGEMENT

I-E-I-E-I (Left Side Front-to-Rear).

I-E-I-E-I (Right Side Front-to-Rear).

VALVE GUIDES

Worn valve guides can be reamed to .008" (.203 mm), .016" (.406 mm), or .032" (.813 mm) oversizes. When going from standard size valve to an oversize, always use reamers in sequence. After reaming, break sharp corner (ID) at top of valve guide. When valve guides are reamed, valve seats must be refaced to maintain proper valve seal.

VALVE STEM OIL SEALS

Cup or umbrella type seals used on all valves. Install seals with cup side down.

VALVE SPRINGS			
Engine	Free Length In. (mm)	PRESSURE Lbs. @ In. (kg @ mm)	
		Valve Closed	Valve Open
2800 cc All	1.99 (50.55)	67-75@1.585 (30-34@40.26)	144-156@1.222 (65-71@31.04)

VALVE SPRINGS

Removal — Remove valve rocker arm cover. Remove rocker arm shaft and both push rods of cylinder to be serviced. Remove spark plug from cylinder and install air line and adapter to cylinder. *NOTE* — If air pressure does not hold valve shut, remove cylinder head for inspection. Use a suitable tool to compress valve, then remove retainer locks. Remove tool, spring retainer, spring, and valve stem seal. **CAUTION** — DO NOT remove air pressure.

Installation — Install NEW valve stem oil seal, valve spring and retainer. Compress spring and install retainer locks. **CAUTION** — Do not compress spring more than necessary to install locks. Remove compressor tool, turn off air and remove adapter. Install remaining components in reverse of removal procedure.

VALVE SPRING INSTALLED HEIGHT

Install valve springs with open spaced coils away from head. Measure distance between cylinder head spring pad and valve spring retainer. Install spacers if necessary to bring spring to proper specifications. **CAUTION** — Excess spacers will result in possible spring breakage and camshaft lobe wear.

Valve Spring Installed Height

Application	In. (mm)
All	1 ³ / ₆₄ - 1 ³⁹ / ₆₄ "

ROCKER ARM ASSEMBLY OVERHAUL

Disassembly — With rocker arm cover removed, remove rocker arm shaft stand bolts and lift off rocker arm assembly. Using a drift, drive lock sleeve (pin) out of rocker. Remove spring washers, rocker arms, springs and rocker shaft supports.

Assembly — Fit shaft supports, springs, rocker arms and spring washers. Install new drive lock sleeve (pin). Rocker arm shaft must be fitted to cylinder head with oil holes facing down toward head. Position notch on front of rocker shaft downward (see illustration).

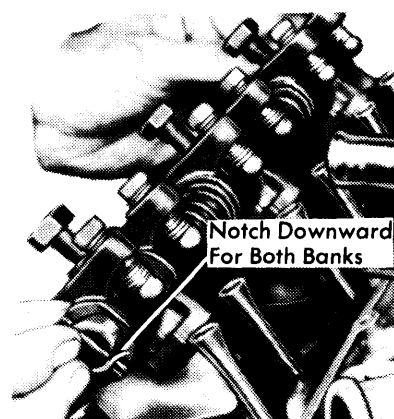

Fig. 3 Rocker Arm Assembly Alignment

VALVE CLEARANCE ADJUSTMENT

Preliminary (Cold) Adjustment — 1) Before adjusting valves, torque rocker arm stand bolts to specifications.

2) Adjust valves at TDC on compression stroke in firing order sequence (1-4-2-5-3-6).

Capri Engines

2800 CC V6 (Cont.)

3) Rotate crankshaft clockwise, (viewed from front), until number one piston is at TDC. Using a step-type feeler gauge (go and no go), adjust intake to .014" and exhaust to .016".

4) Adjust remaining valves by rotating crankshaft a 1/3 of a turn for each cylinder until all valves have been adjusted. Two complete revolutions will adjust all valves.

Final (Hot) Adjustment - 1) Run engine until normal operating temperature is reached.

2) Using a step-type feeler gauge and engine at idle, adjust intake and exhaust valves to .014" intake and .016" exhaust.

PISTONS, PINS, RINGS						
Engine	PISTONS Clearance In. (mm)	PINS		RINGS		
		Piston Fit In. (mm)	Rod Fit In. (mm)	Rings	End Gap In. (mm)	Side Clearance In. (mm)
2800 cc	.0011-.0019 (.028-.048)	.0003-.0006 (.008-.015)	①	Comp. Oil	.015-.023 (.381-.584) .015-.055 (.381-.584)	.0020-.0033 (.051-.084) Snug

① - Interference Fit.

OIL PAN REMOVAL

Removal - Remove oil level dipstick and bolts attaching fan shroud to radiator. Position shroud over fan. Disconnect battery ground cable. Loosen alternator bracket and adjusting bolts. Raise vehicle, drain crankcase, remove splash shield, and starter. Remove engine front support nuts, raise engine, then place wood blocks between front supports and chassis. Remove clutch or converter housing cover, then withdraw oil pan bolts and oil pan.

Installation - Using a suitable sealing compound, coat contact surfaces and place two piece gasket on face of block. Position front and rear oil pan seals in place with tabs of seals lapping over oil pan gasket. Position oil pan on block and tighten bolts as shown in illustration.

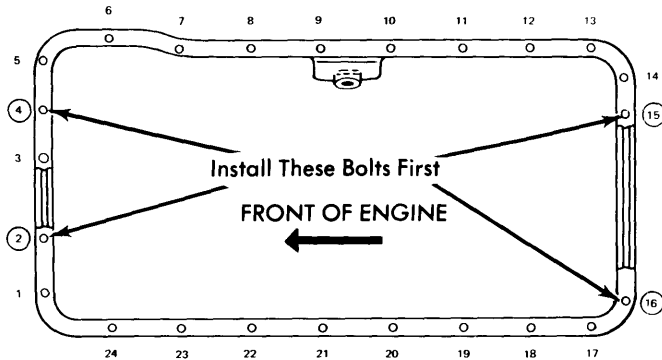

Fig. 4 Oil Pan Tightening Sequence

NOTE - New pistons must be installed in same cylinders for which they were fitted and used pistons in same cylinder from which they were removed.

Removal - With cylinder head and oil pan removed, use a suitable ridge cutter to remove any ridge or deposits on upper end of cylinder bore. **NOTE** - Piston must be at bottom of stroke and covered with cloth to collect cuttings. Inspect connecting rods and caps for cylinder identification and mark as necessary. Remove rod cap and push piston and rod assembly out top of cylinder block taking care not to nick crankshaft journal or cylinder wall.

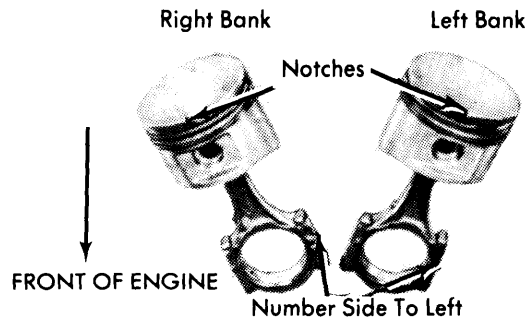

Fig. 5 Piston & Rod Assembly Installation Features

Installation - Lightly coat cylinder bores, pistons and rings with engine oil. Ensure that ring gaps are properly spaced (see illustration) and install ring compressor on piston. Install each piston and rod assembly (with notch on piston head facing front of engine) in its respective bore and guide connecting rod onto crankshaft journal while tapping piston head with hammer handle to seat connecting rod against crankshaft. Install rod caps and tighten.

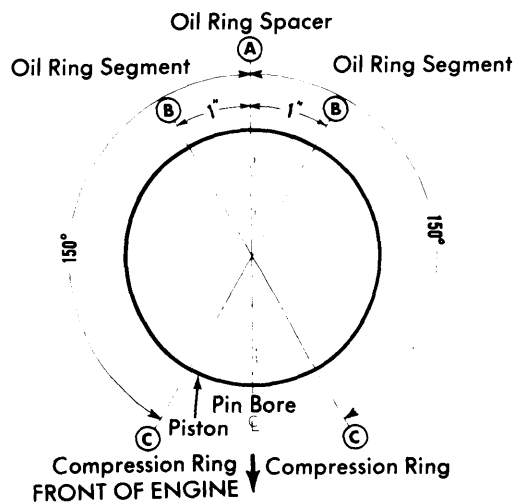

Fig. 6 Spacing of Piston Ring Gaps

2800 CC V6 (Cont.)

FITTING PISTONS

Check piston to cylinder bore clearance by measuring piston and bore diameters. Measure OD of piston at centerline of piston pin bore and at 90° to pin bore axis. Refer to specifications for correct clearance. Oversize pistons are available in .020" and .040" oversizes.

PISTON PIN REPLACEMENT

Piston pin bore and OD of piston pin must be within specifications. Remove old pin using an arbor press and suitable piston support and driver tool. Assemble piston to rod with notches on piston facing forward. Rod numbers face to left side of engine (see illustration).

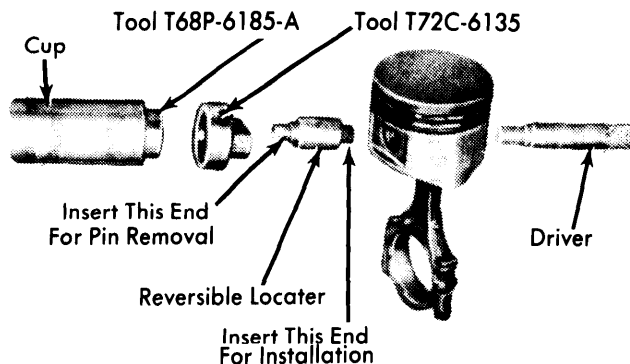

Fig. 7 Piston Pin Installation Tools

CRANKSHAFT MAIN & CONNECTING ROD BEARINGS

Engine	MAIN BEARINGS				CONNECTING ROD BEARINGS		
	Journal Diam. In. (mm)	Clearance In. (mm)	Thrust Bearing	Crankshaft End Play In. (mm)	Journal Diam. In. (mm)	Clearance In. (mm)	Side Play In. (mm)
2800 cc All	2.2433-2.2441 (56.980-57.000)	.0005-.0019 (.013-.048)	No. 3	.004-.008 (.10-.20)	2.1252-2.1260 (53.980-54.000)	.0005-.0022 (.012-.056)	.004-.011 (.10-.28)

MAIN & CONNECTING ROD BEARINGS

NOTE — Following procedures are with oil pan and oil pump removed.

Connecting Rod Bearings — After ensuring rod caps are marked for cylinder identification, remove rod caps. Use Plastigage method to check for proper bearing clearance. If not within specifications, new bearings must be installed. New bearings are available in .001" (.025 mm) and .002" (.051 mm) undersizes. Selective fitting is required on each connecting rod. A standard bearing may be used in combination with either undersize bearing. **NOTE** — Always replace bearings in pairs. Never use a new bearing in combination with a used bearing. Coat bearing surface with oil, install rod cap and tighten nuts.

Main Bearings — 1) Position jack under counterweight adjoining bearing being checked so weight of crankshaft will not compress Plastigage and provide an erroneous reading. With all bearing caps (other than one being checked) tight, check clearances using Plastigage method.

2) If clearances are excessive, a .001" (.025 mm) or .002" (.051 mm) undersize bearing may be used in combination with a standard bearing. If .002" (.051 mm) undersize bearings are used on more than one journal, they must be positioned in cylinder block rather than bearing cap. **NOTE** — Always replace bearings in pairs. Never use a new bearing in combination with a used bearing. If standard and .002" (.051 mm) undersize combination do not bring bearing clearance within specified limits, crankshaft will have to be refinished and undersized bearings installed.

3) Remove all upper main bearings (except rear main) by inserting suitable tool in oil hole of crankshaft journal and rotating crankshaft clockwise to roll bearing from engine. Oil

new upper bearing and insert plain (unnotched) end between crankshaft and indented (or notched) side of block. Rotate bearing into place. Install all main bearing caps with arrows pointing to front of engine. **NOTE** — If rear main bearing is to be replaced, engine must be removed from vehicle.

THRUST BEARING ALIGNMENT

Install all bearing caps except thrust bearing cap and tighten. Install thrust bearing cap with bolts finger tight. Pry crankshaft to front of engine and hold forward while prying thrust bearing cap to rear. Hold crankshaft forward and tighten bolts on thrust bearing cap. Check crankshaft endplay.

REAR MAIN BEARING OIL SEAL

Removal — Remove transmission, clutch pressure plate and disc (if equipped), flywheel, flywheel housing and rear plate. Remove old seal using two sheet metal screws (see illustration) while taking care not to damage oil sealing surface.

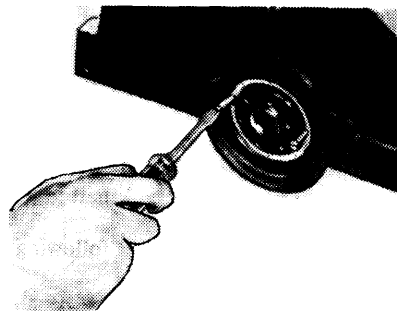

Fig. 8 Using Metal Screws to Remove Crankshaft Rear Oil Seal

2800 CC V6 (Cont.)

Installation — Coat seal-to-cylinder block surface of oil seal with oil. Coat seal contact surface of oil seal and crankshaft with Lubriplate. Start seal in recess and install with suitable tool (T72C-6165). Drive seal into position until firmly seated.

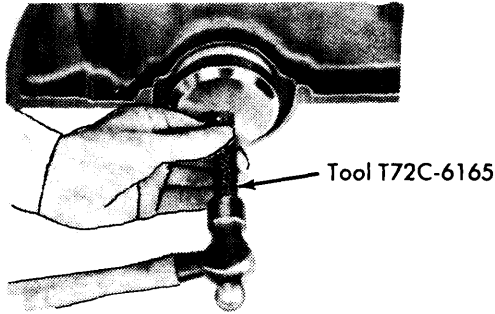

Fig. 9 Installing Crankshaft Rear Oil Seal

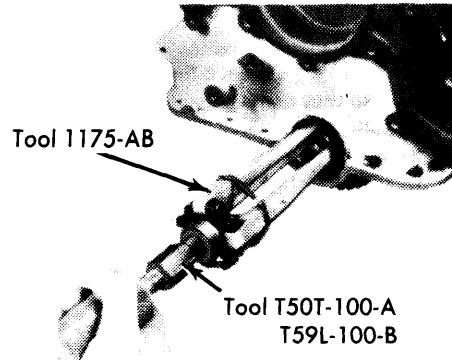

Fig. 11 Removing Front Oil Seal

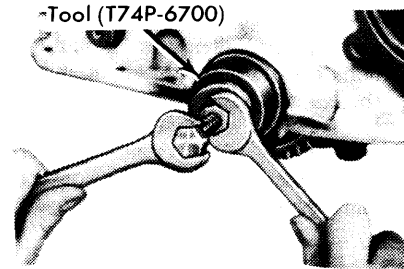

Fig. 12 Installing Front Oil Seal

ENGINE FRONT COVER

Removal — Remove oil pan, radiator, alternator, drive belts, water pump, and water hoses. Remove drive belt pulley and if necessary, remove guide sleeves from block. Remove front cover attaching bolts. Tap cover with a plastic hammer to break seal and remove cover.

Installation — Apply sealing compound to gasket surfaces on cylinder block and both sides of gasket. Position gasket and front cover, then install retaining bolts. Fit new seal rings to guide sleeve and insert guides in block with chamfered end toward front cover. Apply sealer to front cover and place gasket on cover. Using suitable alignment tool (T74P-6019) to center cover, then install and tighten bolts.

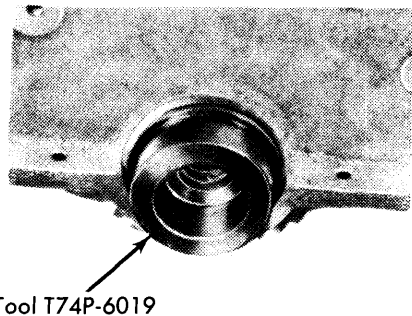

Fig. 10 Using Tool to Align Engine Front Cover

FRONT COVER OIL SEAL

Removal & Installation — Remove radiator and crankshaft pulley. Using a suitable pulling tool (as shown in illustration), remove front cover oil seal. To install a new seal, coat seal with Lubriplate and slide installing tool (T74P-6700) and seal onto crankshaft. Seat seal until tool bottoms out on front cover. Reinstall crankshaft pulley, radiator and adjust drive belt.

CAMSHAFT			
Engine	Journal Diam. In. (mm)	Clearance In. (mm) ①	Lobe Lift In. (mm)
2800 cc Front	1.6497-1.6505 (41.902-41.923)	.001-.0026 (.025-.066)	.2555 (6.49)
No. 2	1.6347-1.6355 (41.521-41.542)		
No. 3	1.6197-1.6205 (41.140-41.161)		
Rear	1.6065-1.6073 (40.805-40.825)		

① — Endplay is .0008-.0040" (.02-.10 mm).

TIMING GEARS

Using a dial indicator, check that backlash between camshaft gear and crankshaft gear is .006-.010" (.15-.25 mm). If backlash exceeds specifications, replace both gears as follows:

Removal — Drain cooling system and crankcase. Remove radiator, oil pan, front cover and water pump. Remove camshaft gear retaining bolt and slide gear off camshaft. Use a suitable gear puller and remove crankshaft gear.

Installation — Turn camshaft and crankshaft as necessary to align timing marks (see illustration) and install camshaft gear. Install retaining washer and bolt, then tighten. Install

2800 CC V6 (Cont.)

crankshaft gear. Recheck that timing marks line up as shown in illustration. Install remaining components in reverse of removal procedure.

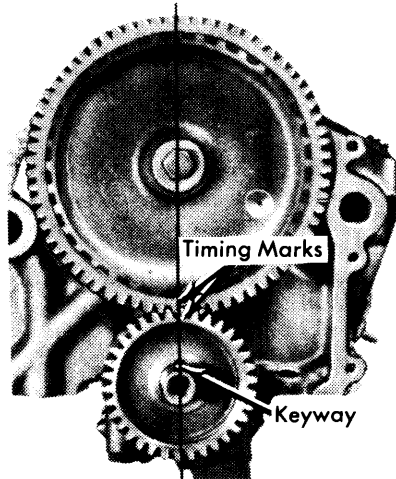

Fig. 13 Aligning Camshaft Timing Marks

CAMSHAFT

Removal – Drain cooling system and remove radiator, fan, spacer, water pump pulley, and drive belt. Remove intake manifold, carburetor, and alternator. Drain crankcase and remove rocker arm and shaft assemblies. Remove push rods and mark for installation in original position. Remove oil pan, crankshaft pulley, front cover, and camshaft gear. Remove camshaft thrust plate and screws. Remove valve lifters. Carefully pull camshaft from cylinder block taking care not to damage bearings.

Installation – Oil camshaft journals with engine oil and apply Lubriplate to cam lobes. Carefully install camshaft in engine. Install spacer ring (chamfered side toward camshaft), camshaft key and thrust plate (covering main oil gallery). Reverse removal procedure for remaining parts.

ENGINE OILING

ENGINE OILING SYSTEM

The V-6 engine is pressure feed by a rotor type oil pump, which filters all oil through a full flow filter before entering engine. An oil gallery supplies oil to crankshaft main bearings, from there through slanted passages in crankshaft to connecting rod journals. Connecting rod big ends have a squirt hole which sprays oil on thrust side of cylinder bores. Oil from the oil gallery also feeds camshaft main bearings, which have grooves 180° of their circumference. From these grooves passages lead to distributor drive gear and rocker arm shafts.

Crankcase Capacity – 4.5 quarts. Add .5 quart with filter change.

Oil Filter – Full flow type.

CAMSHAFT BEARINGS

Removal – With engine removed from vehicle, remove flywheel, camshaft and rear bearing bore plug. Use suitable collet and back-up nut assembled on expanding mandrel to remove bearings.

Installation – Position new bearings at bearing bores and press into place using correct size expanding collet being sure to center pulling plate and puller screw to avoid damage to bearing. Align oil holes in cylinder block when bearings are installed. Front edge of No. 1 bearing must be installed .040-.060" (1.0-1.5 mm) below front face of cylinder block.

CAMSHAFT END THRUST

Rocker arm shaft assembly must be loosened sufficiently to free camshaft. Push camshaft toward rear of engine and install dial indicator so point is on camshaft sprocket bolt. Zero indicator. Position screwdriver between camshaft gear and block, pull camshaft forward and release. If endplay is excessive, replace thrust plate. **CAUTION** – Do not attempt to pry camshaft back and forth with valve train load on camshaft.

CHECKING CAMSHAFT LOBE LIFT

Check lift of each camshaft lobe in consecutive order as follows:

- 1) Remove rocker arm shaft assemblies, making sure each push rod is in valve lifter socket. Install a dial indicator so that ball socket adapter of indicator rests on the end of push rod and in same plane as push rod movement.
- 2) With an auxiliary starter switch connected to starter solenoid and ignition switch "OFF", bump crankshaft until tappet is on base circle of camshaft lobe. This will be push rods lowest point.
- 3) Zero dial indicator and continue to rotate crankshaft until push rod is in fully raised position (highest indicator reading). Compare total lift from indicator readings with specifications.
- 4) To check accuracy of indicator readings, continue to rotate crankshaft until indicator reads zero. If lift on any lobe is .005" less than specifications, camshaft and tappet operating on worn lobe must be replaced.

Normal Oil Pressure – 40-55 psi @ 2000 RPM.

Pressure Regulator Valve – Non-adjustable.

OIL PUMP

Disassembly – Remove pick-up tube and screen assembly from pump housing. Remove cover and lift out two-piece rotor assembly. Drill a small hole and insert self-threading sheet metal screw into oil pressure relief valve plug and remove plug. Remove spring and valve.

Reassembly – Clean, inspect (see specifications) and oil all parts. Install relief valve, spring and new plug in oil pump housing. Install plug with flat side pointing out and spread plug in housing using a drift. Install inner and outer rotors and shaft assembly in housing with dot reference marks up. Install cover and pick-up tube assembly.

Capri Engines

2800 CC V6 (Cont.)

ENGINE OILING (Cont.)

Oil Pump Specifications

Clearance	Specification In. (mm)
Outer Race-to-Housing006-.012(.15-.30)
Rotor Endplay0011-.0041(.028-.104)
Shaft-to-Housing0014-.0029(.036-.074)
Relief Valve-to-Bore0015-.0030(.038-.076)

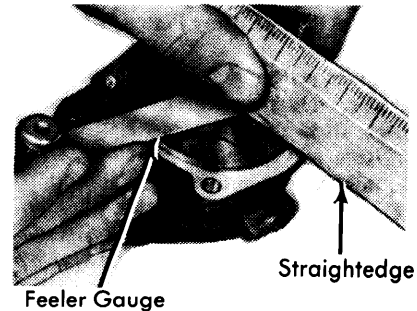

Fig. 14 Measuring Oil Pump Rotor End Play

Relief Valve Spring Pressure — 13.6-14.7 Lbs. @ 1.39" (6.17-6.67 kg @ 35.3 mm).

ENGINE COOLING

WATER PUMP

Removal — Drain cooling system. Remove lower radiator hose, and heater return hose. Loosen alternator mounting bolts and remove drive belt. Disconnect fan shroud from radiator and position behind fan. Remove fan, pulley and shroud. Remove attaching bolts, water pump, water inlet housing and thermostat from front cover.

Installation — Apply sealer to both sides of a new gasket and position gasket on water pump. Position water pump on front cover with two bolts finger tight. Install new water inlet housing gasket, with sealer on both sides, to water pump. Install thermostat, rubber gasket, and water inlet housing. Install and tighten remaining water pump attaching bolts while noting different length bolts. Reinstall, fan, pulley, shroud, drive belt and hoses. Fill cooling system.

Thermostat

Starts to Open 185-192°F(85-89°C)
Fully Open 210-216°F(99-102°C)

Cooling System Capacity — 8.5 quarts.

Pressure Radiator Cap — Opens at 13 psi.

TIGHTENING SPECIFICATIONS

Application	Ft. Lbs. (mkg)
Camshaft Gear	32-36(4.4-5.0)
Camshaft Thrust Plate	12-15(1.7-2.1)
Connecting Rod Bearing Cap	21-25(2.9-3.5)
Crankshaft Damper	92-103(12.7-14.2)
Crankshaft Pulley-to-Damper	18-25(2.5-3.5)
Cylinder Head	
Step One	29-40(4.0-5.5)
Step Two	40-51(5.5-7.1)
Step Three	65-80(9.0-11.1)
Exhaust Manifold	16-23(2.2-3.2)
Flywheel	47-51(6.5-7.1)
Front Cover	12-15(1.7-2.1)
Intake Manifold	
Step One	3-6(.4-.8)
Step Two	6-11(.8-1.5)
Step Three	11-16(1.5-2.2)
Step Four	15-18(2.1-2.5)
Main Bearing Cap	65-75(9.0-10.4)
Oil Pan	5-7(.7-1.0)
Oil Pump 12-15(1.7-2.1) Rocker Arm Cover	3-5(.4-.7)
Rocker Shaft Supports	43-49(5.9-6.8)
Water Pump	7-9(1.0-1.2)