

Drive Axles

1968-74 DATSUN INTEGRAL HOUSING (I.R.S.)

510 (1968-72)
 610 Sedan & Hardtop (1973-74)
 240Z (1970-73)
 260Z (1974)

DESCRIPTION

The axle assembly is the hypoid gear type with integral carrier housing. The pinion bearing preload adjustment is made with a spacer and washer between the front and rear bearing cones. The differential side bearing preload and the pinion depth adjustment are made by shims. Driving power is transmitted to the rear axle by ball spline type driveshaft with universal joints at both ends.

AXLE RATIO & IDENTIFICATION

All Datsun models with Independent Rear Suspension (I.R.S.), use one basic type rear axle assembly. Any differences in Removal & Installation or Overhaul procedures will be noted where they occur. To determine axle ratio, divide number of ring gear teeth by number of pinion teeth.

REMOVAL & INSTALLATION

AXLE SHAFT & BEARINGS

Removal — Raise and support vehicle and remove wheel and brake drum. Disconnect driveshaft from axle shaft outer flange. Remove wheel bearing lock nut while holding axle

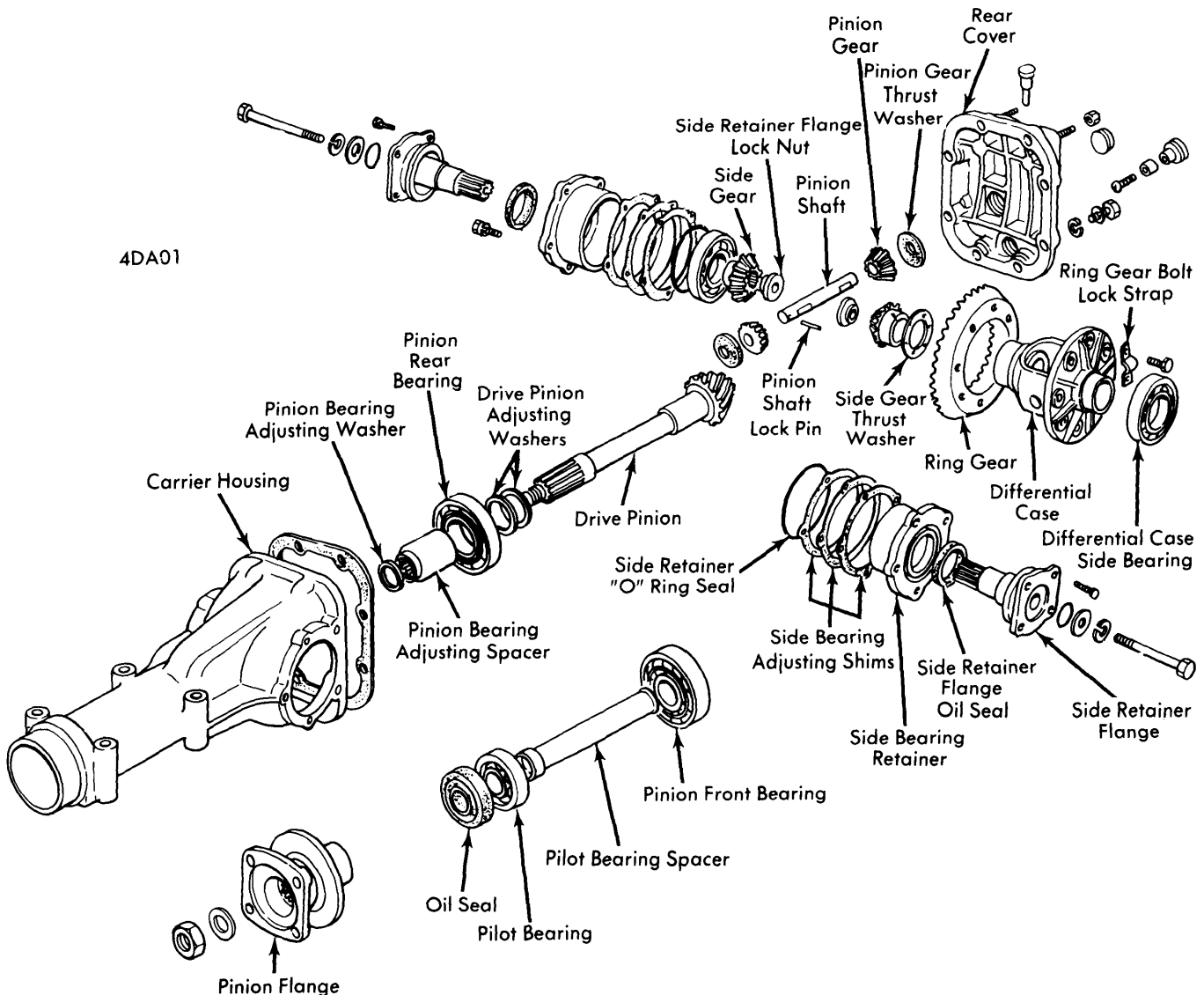

REAR AXLE ASSEMBLY (MODEL 610 SHOWN)

1968-74 DATSUN INTEGRAL HOUSING (I.R.S.) (Cont.)

shaft outer flange stationary. Using suitable axle stand (ST07640000) and slide hammer, remove axle shaft. Remove wheel bearing spacer, companion flange and bearing washer, then remove inner wheel bearing and oil seal. Remove grease catcher, then press or pull outer wheel bearing from axle shaft. **NOTE** — Do not reuse old outer wheel bearing.

Installation — To install, reverse removal procedure and note the following: Clean and inspect all parts for wear or damage and replace as necessary. Grease wheel bearings and housing before installation. When installing bearings ensure outer bearing is installed with seal towards wheel and that inner bearing is installed with seal facing differential. A mark "A", "B" or "C" is stamped on axle housing. Ensure that bearing spacer with same mark is installed. Tighten all bolts and nuts and adjust wheel bearings.

Wheel Bearing Adjustment — After tightening wheel bearing lock nut to specification, check that axle shaft end play is .006" (.15 mm) or less. Check that turning torque of axle shaft is less than 1.8 lbs. (.8 kg) at hub bolt. If either adjustment is not to specification, disassemble axle shaft assembly and replace bearing spacer.

DRIVE SHAFTS

Removal & Installation — Raise and support rear of vehicle on safety stands. Disconnect drive shaft from axle shaft companion flange. Remove differential side yoke attaching bolt and lift out side yoke and drive shaft as an assembly. To install, reverse removal procedure and note the following: Exercise care when installing assembly to prevent damage to side yoke and oil seal. Tighten all bolts to specifications.

PINION FLANGE & OIL SEAL

Removal — Drain gear oil from differential, then raise and support rear of vehicle. Disconnect propeller shaft from pinion flange, then if necessary remove muffler and disconnect parking brake cable. On 240Z and 260Z models remove rear stabilizer from vehicle. On all models, remove pinion nut, while holding pinion flange stationary. Using a suitable puller remove pinion flange. Remove oil seal using suitable puller (ST33290001).

Installation — To install, reverse removal procedure and note the following: Apply suitable grease between seal lips before installation. Tighten pinion nut to specifications and ensure pinion bearing preload is correctly adjusted. Fill differential to proper level with gear oil.

AXLE ASSEMBLY

Removal — Raise and support rear of vehicle. On all models except 240Z and 260Z, disconnect parking brake cable from turnbuckle. On 240Z and 260Z models, remove main muffler. On all models, disconnect propeller shaft from axle assembly. On 240Z and 260Z models, loosen front side transverse link inner bolts. On all models, remove axle drive shafts. Support axle assembly on a jack, then remove nuts on both ends of axle assembly rear mounting member. Remove axle assembly front mount attaching bolts, lower assembly on jack and remove from vehicle. **NOTE** — On all models except 240Z and 260Z, support suspension member to prevent damage to insulators.

Installation — To install, reverse removal procedure and note the following: Install same size mounting spacer between axle assembly and front mount. Tighten all nuts and bolts to specifications and fill assembly to correct level with gear oil.

DRIVE SHAFT OVERHAUL

DISASSEMBLY

NOTE — Drive shaft should be disassembled only to lubricate ball spline.

Remove universal joint from differential end of drive shaft. Remove snap ring from sleeve yoke plug and remove plug. Compress drive shaft and remove snap ring from stopper, then remove stopper. Disconnect boot and separate drive shaft carefully so as not to lose balls and spacers.

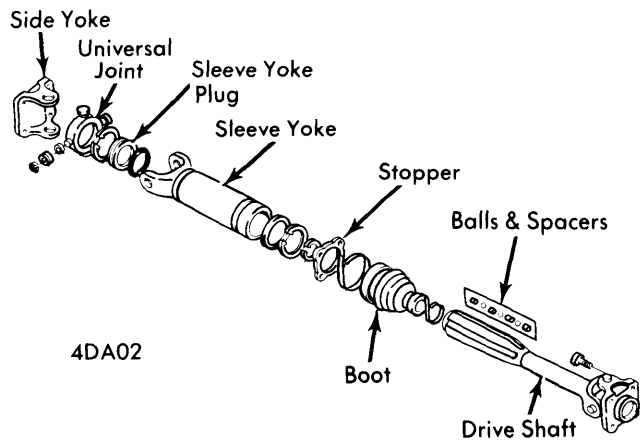

DRIVE SHAFT ASSEMBLY

INSPECTION

Check rubber boot and oil seals for damage and replace as necessary. Inspect drive shaft for straightness, cracks, damage and distortion and replace drive shaft if necessary. Check all other drive shaft components for wear, damage and distortion and replace complete drive shaft assembly if any faulty part is found. Check drive shaft play as shown in illustration and replace complete assembly if play exceeds .004" (1 mm). **NOTE** — Measurement should be taken with drive shaft fully compressed.

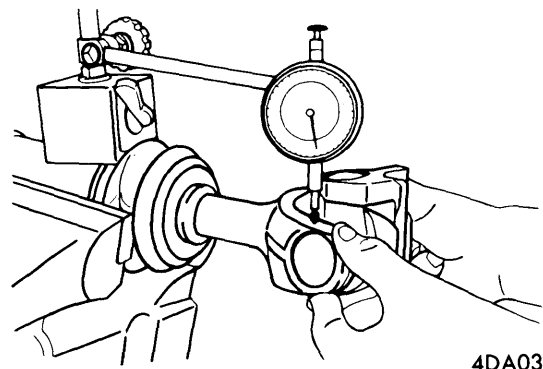

MEASURING DRIVE SHAFT PLAY

1968-74 DATSUN INTEGRAL HOUSING (I.R.S.) (Cont.)

3) When replacing side bearings, measure bearing width with a .787" (20 mm) gauge and a 5.5 lb. (2.5 kg) weight block. Bearing width should be slightly smaller than gauge. Press fit side bearing inner race on differential case and side bearing outer race into side retainers. Install new oil seal on side retainer and apply grease to cavity between seal lips.

Drive Pinion Preload - 1) *NOTE* - Perform adjustment without pinion shaft oil seal installed. Press fit front and rear bearing outer races into gear carrier. Insert suitable dummy shaft spacer (ST31851000), pinion height adjusting spacer and rear bearing inner race into suitable dummy shaft (ST31212000).

2) Fit drive pinion bearing spacer, washer, front bearing inner race, suitable dummy shaft collar (ST31214000) and pinion flange on dummy shaft and tighten drive pinion nut to specified torque.

3) Measure pinion bearing preload using suitable preload gauge (ST3127S000) and select washer and spacer that will provide specified preload. *NOTE* - Preload of old bearing is the same as that of a new bearing. Pinion bearing adjusting washers are available in thicknesses of .0906-.1024" (2.3-2.6 mm). Pinion bearing adjusting spacers are available in lengths of 2.2126-2.2520" (56.2-57.2 mm) on 610 models and 2.0551-2.0945" (52.2-53.2 mm) on all other models.

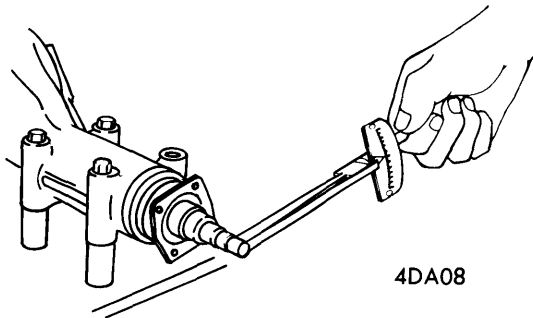

4DA08
ADJUSTING DRIVE PINION PRELOAD

Drive Pinion Height - 1) Install suitable height gauge (ST31211000) on gear carrier with dummy shaft mounted. Measure clearance between tip end of height gauge and end surface of dummy shaft. Thickness of drive pinion height adjusting washer can be obtained by the following formula:

$$T = W + N - (H - D' - S) \times .01 - .2$$

NOTE - Formula values are given in Millimeters.

- T = Thickness of adjusting washer needed.
- W = Thickness of washer temporarily installed.
- N = Clearance between gauge and dummy shaft.
- H = Figure marked on drive pinion head.
- D' = Figure marked on dummy shaft.
- S = Figure marked on height gauge.

NOTE - If values signifying H, D, and S are not given, regard them as zero.

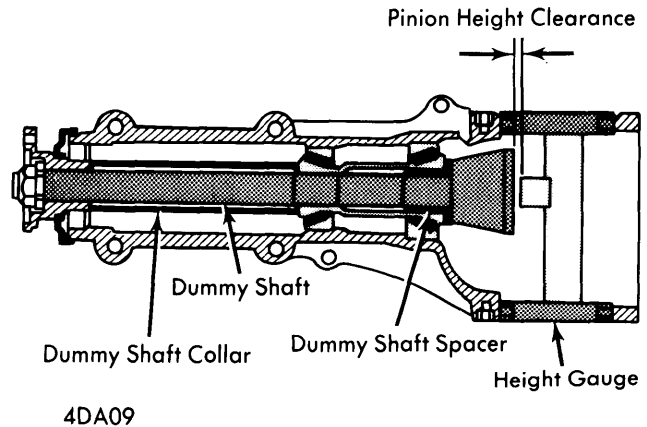

4DA09
MEASURING DRIVE PINION HEIGHT

2) Fit correct pinion height adjusting washer in drive pinion and press fit rear bearing inner race. Lubricate pinion front and rear bearings, then install drive pinion in carrier along with drive pinion bearing spacer and washer, front bearing race, front bearing pilot spacer, pilot bearing and oil seal. Install pinion flange and tighten pinion nut to specifications.

Side Bearing Preload - 1) Required thickness of left and right side retainer shims can be obtained by the following formulas:

$$T_1 = (A + C + G_1 - D) \times .01 + .76 - E$$

$$T_2 = (B + D + G_2) \times .01 + .76 - F$$

NOTE - Formula values are given in Millimeters.

- T₁ = Required thickness of left side retainer shim.
- T₂ = Required thickness of right side retainer shim.
- A & B = Figure marked on gear carrier.
- C & D = Figure marked on differential case.
- E & F = Difference in width of left or right bearing.
- G₁ & G₂ = Figure marked on left or right retainers.

NOTE - If values signifying A, B, C, D, G₁, and G₂ are not given, regard them as zero.

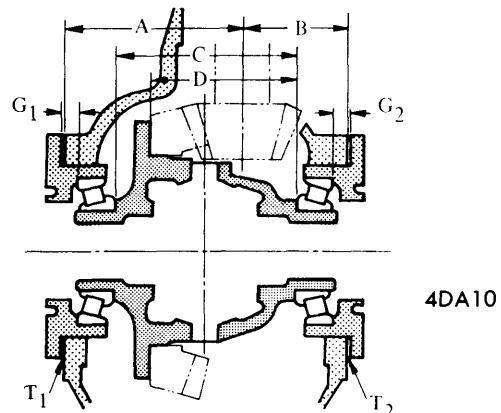

4DA10
SIDE BEARING PRELOAD FORMULA VALUES

Drive Axles

1968-74 DATSUN INTEGRAL HOUSING (I.R.S.) (Cont.)

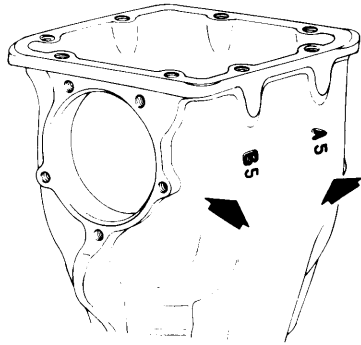

Gear Carrier

4DA11

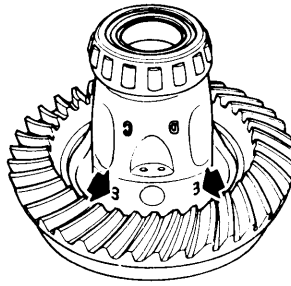

Differential Case

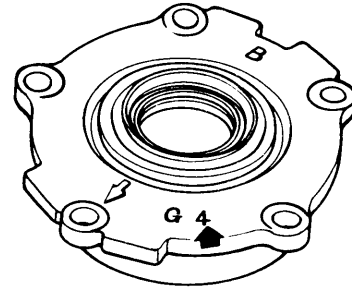

Side Retainer

SIDE BEARING PRELOAD IDENTIFICATION MARKS

2) Install differential case assembly in gear carrier in reverse order of disassembly. Fit correct shims and "O" ring seal in both side retainers and install retainers in carrier with arrow pointing as shown in illustration.

Final Inspection & Assembly — After all adjustments are to specifications, make tooth contact pattern test and make any necessary corrections. See *Gear Tooth Contact Pattern at beginning of this section*. Install rear cover and tighten nuts to specifications. Refill axle assembly to correct level with gear oil.

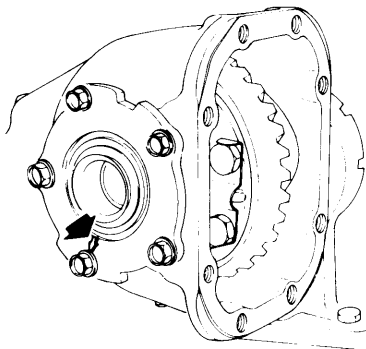

4DA12

INSTALLING SIDE RETAINER

3) Using dial indicator, measure ring gear-to-drive pinion backlash and adjust if necessary. Check side bearing preload, and adjust if necessary by adding or removing side retainer shims. **NOTE** — If side bearing preload is readjusted, ring gear-to-drive pinion backlash must be checked and adjusted if necessary.

AXLE ASSEMBLY SPECIFICATIONS	
Pinion Bearing Preload	
260Z.....	8.7-11.4 INCH Lbs. (10-13 cmkg)
All Others ①.....	6.1-8.7 INCH Lbs. (7-10 cmkg)
Side Bearing Clearance ②.....	.004-.008" (.1-.2 mm)
Side Bearing Preload	
240Z & 260Z.....	10.4-17.3 INCH Lbs. (12-20 cmkg)
All Others.....	7.8-14.8 INCH Lbs. (8-17 cmkg)
Side Bearing Rotating Torque ③	
240Z & 260Z.....	7.7-12.8 Lbs. (3.5-5.8 kg)
All Others.....	5.7-10.8 Lbs. (2.6-4.9 kg)
① — Preload for 1973 240Z is same as 260Z.	
② — Between thrust washer.	
③ — At side retainer companion flange.	

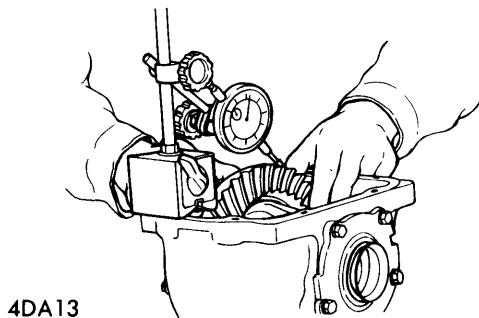

4DA13

MEASURING RING GEAR BACKLASH

TIGHTENING SPECIFICATIONS	
Application	Ft. Lbs. (mkg)
Rear Wheel Bearing Nut.....	181-239 (25-33)
Drive Shaft Flange Bolt.....	36-43 (5-6)
Drive Shaft Side Yoke Bolt.....	23-31 (3.2-4.3)
Axle Assembly Mounting Bolts	
Front.....	36-51 (5-7)
Rear.....	54-69 (7.5-9.5)
Transverse Link Inner Bolt	
(240Z & 260Z).....	94-101 (13-14)
Drive Pinion Nut.....	123-145 (17-20)
Ring Gear Bolts.....	51-58 (7-8)
Side Retainer Bolt.....	7-9 (.9-1.2)
Rear Cover Bolts.....	14-19 (1.9-2.6)
Rear Cover-to-Mounting Member.....	54-69 (7.5-9.5)