

## 1968-74 BMW INTEGRAL CARRIER

1600 Series (1968-69)  
1800 Series (1968)  
2000 Series (1968-69)  
2002 Series (1968-74)

### DESCRIPTION

Differential has hypoid ring and drive pinion gear set and may have a clutch pack type limited slip unit. Differential housing has removable rear cover. Differential carrier is retained in the sides of the housing by retaining plates, and is supported by roller bearings. Drive pinion gear is supported by roller bearings, and in addition, a long neck housing has a ball bearing supporting the drive pinion at the companion flange. Drive pinion preload is maintained by a collapsible spacer in the short neck housing, and by a spacer and shims in the long neck housing.

### AXLE RATIO & IDENTIFICATION

The ring and pinion gear set with Klingelnberg tooth design, can be identified by the letter "K" stamped on the head of the drive pinion gear; Gleason teeth are noted by an "H" or "F" stamping. To determine axle ratio, divide number of ring gear teeth by number of drive pinion gear teeth. The number of teeth on ring and drive pinion gears is stamped on forward left side of differential housing.

### REMOVAL & INSTALLATION

#### DRIVE SHAFTS & UNIVERSAL JOINTS

Remove drive shaft after removing retaining bolts from axle and half shaft flanges. For universal joint or dust boot replacement, use the appropriate procedure below.

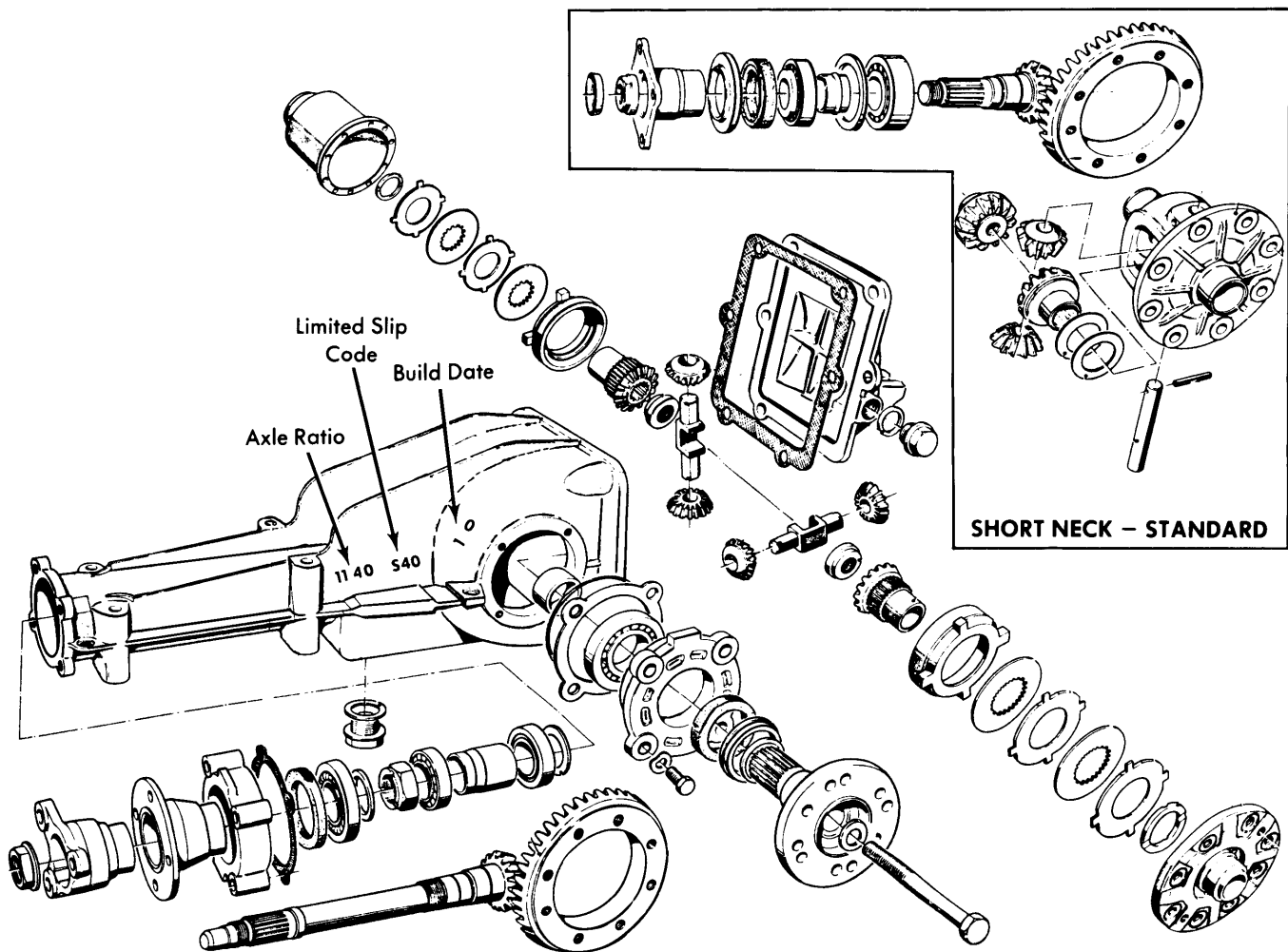

4BMW02

### DIFFERENTIAL ASSEMBLY (LONG NECK - LIMITED SLIP)

## 1968-74 BMW INTEGRAL CARRIER (Cont.)

**Constant Velocity Joint** — Remove cover from joint housing, then remove snap ring from end of drive shaft. Remove clamps from boot then press drive shaft from joint. Remove dust boot. To install, reverse removal procedure using sealer on boot-to-joint surfaces and install seal cover after packing joint with suitable grease.

**Sliding U-Joint** — Drain oil from joint, note position of hose clamps, then remove clamps. Pull off housing and roller caps and coat needle bearings with grease. Remove dust boot from spacer ring and then remove boot and ring. To install, reverse removal procedure, locating hose clamps in original position.

**Cross and Roller U-Joint** — *NOTE* — If yoke is bent or twisted, complete drive shaft must be replaced. Remove bearing cup snap rings, then press out bearing cups using suitable arbor press or vise and supporting tools. Remove cross assembly from yoke. To install, hold cross between ears of drive shaft and partially install two bearing cups. Align cross with cups, then using arbor press or vise, press cups into yoke until snap rings can be inserted.

### AXLE SHAFTS & BEARINGS

Raise and support vehicle. Remove wheel, loosen castellated nut securing flange to axle shaft, then using a suitable puller, remove flange. Remove drive shaft, then using a soft headed mallet, drive axle shaft inward and out of housing. Drive out bearings and seals, then remove spacer sleeve and shim. To install, reverse removal procedure noting the following: Install inner bearing, then determine distance between outer races of inner and outer bearings. Measure spacer and shim, then install spacer and a suitable shim that will obtain a wheel bearing play of .002-.004" (.05-.10 mm). Pack bearings and hub with suitable grease, then using new seals, complete installation procedure.

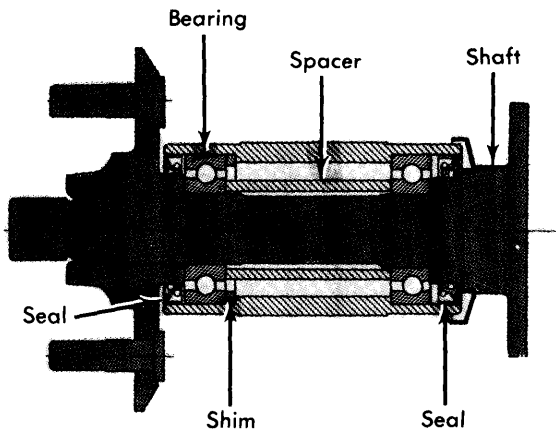

4BMW01

**AXLE SHAFT ASSEMBLY**

### DRIVE PINION COMPANION FLANGE OIL SEAL

*NOTE* — On short neck differential housing, complete disassembly of differential is required for seal replacement. Refer to Drive Pinion Gear Removal and Installation procedures for seal replacement.

**Long Neck Differential Housing** — Remove propeller shaft, nut retaining companion flange on drive pinion gear, companion flange, and seal. To install, reverse removal procedure insuring seal installed depth is .24" (6 mm) from front of seal to front edge of housing.

### AXLE FLANGE & OIL SEAL

**Removal** — Remove drive shaft. Hold axle flange using suitable tools (604 wrench; 6040 Spacer) then remove flange retaining bolt. Using a suitable puller (20/10) and support bracket (7011-1) remove axle flange. Remove oil seal.

4BMW03

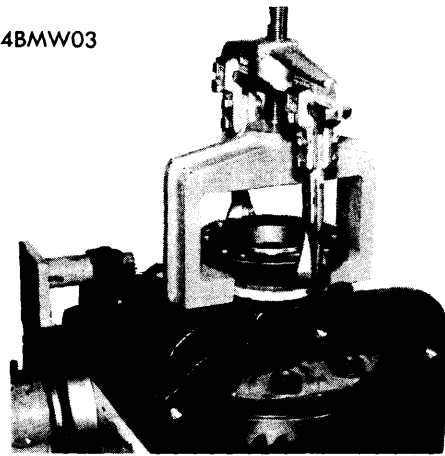

**REMOVING AXLE DRIVE FLANGE**

**Installation** — Fill between sealing lips of seal with grease, then install seal in retaining plate to a depth of .16" (4 mm). Thoroughly clean flange and carrier splines and if any backlash between splines exists, apply small amount of locking compound to flange splines. Install flange and retaining bolt.

### DIFFERENTIAL ASSEMBLY

Remove propeller shaft and drive shafts, tie drive shafts up out of way. Support differential and remove four frame-to-housing attaching bolts, two differential cover-to-bracket nuts, and two bracket-to-frame bolts. Remove differential assembly. To install, reverse removal procedure, insuring rear bracket is stress free when installed.

## OVERHAUL

### DISASSEMBLY

**Differential Housing** — Remove differential assembly as previously outlined, and mount assembly in suitable holding fixture. Drain oil and mark drive pinion shaft and companion flange for reassembly reference. Remove rear cover plate. Remove both axle flanges, as previously described, keeping right and left side parts separated. Mount a dial indicator to housing, and check ring gear runout for reference at time of

## 1968-74 BMW INTEGRAL CARRIER (Cont.)

reassembly. Make a gear tooth pattern check. *NOTE* — Refer to *Rear Axle Gear Tooth Patterns* in this section. Mark and remove carrier bearing retainer plates and shims. Turn housing rear opening upward, move carrier to right side, tilt and remove carrier from housing. Proceed as follows for standard or limited slip differential carrier disassembly.

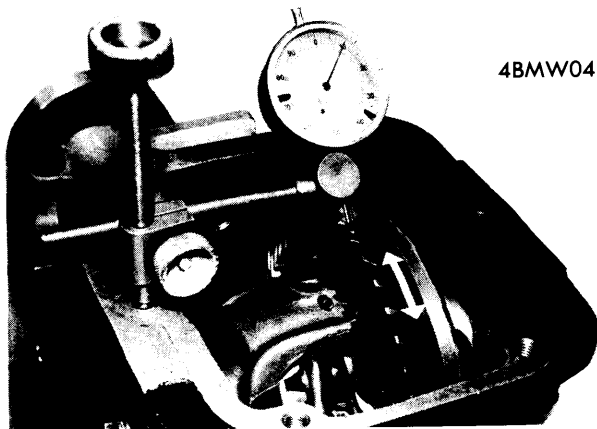

4BMW04

**CHECKING RING GEAR BACKLASH**

**Standard Differential Carrier** — Remove carrier bearings using suitable puller (Rollex LM503349). Remove bolts securing ring gear to carrier, then remove ring gear. Drive out pinion shaft lock pin, remove pinion gears shaft and pinion gears. Remove side gears with shims and thrust washers.

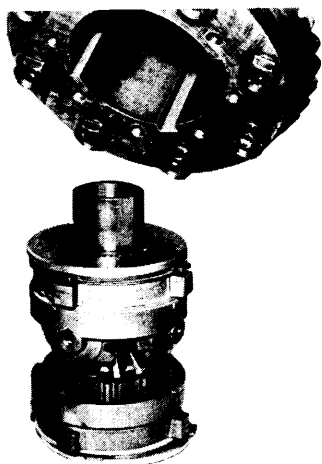

4BMW05

**LIMITED SLIP CASE & CLUTCH ASSEMBLY**

**Limited Slip Differential Carrier** — Remove carrier bearings using suitable puller (HM 89449). Remove bolts securing case cover to ring gear flange, invert case and lift case off clutch and gear assembly. Separate ring gear from flange. Remove clutch components, lift off hub, remove side gear and one set of pinion gears. Repeat procedure for other half of case.

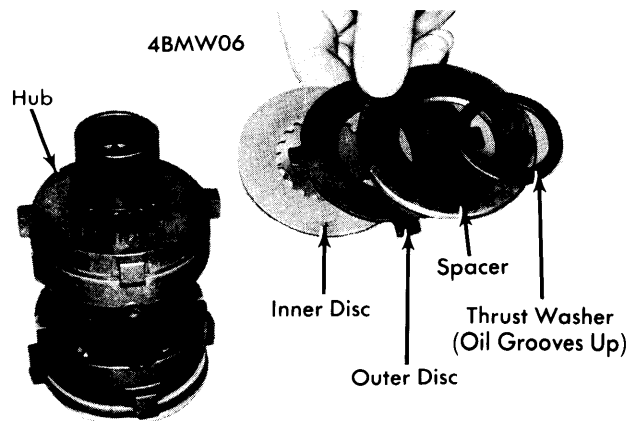

**LIMITED SLIP CLUTCH ASSEMBLY**

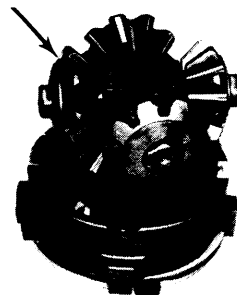

4BMW07

**LIMITED SLIP SIDE & PINION GEAR ASSEMBLY**

**Drive Pinion Gear** — 1) Remove differential carrier as previously outlined, then using an inch pound torque wrench, check preload on drive pinion gear. Hold companion flange and remove retaining nut. Press drive pinion from flange and housing, then remove bearings. *NOTE* — On long neck housing, first remove flange nut, flange, cover and shim. Using a suitable tool (6046) remove drive pinion lock nut, then press gear out.

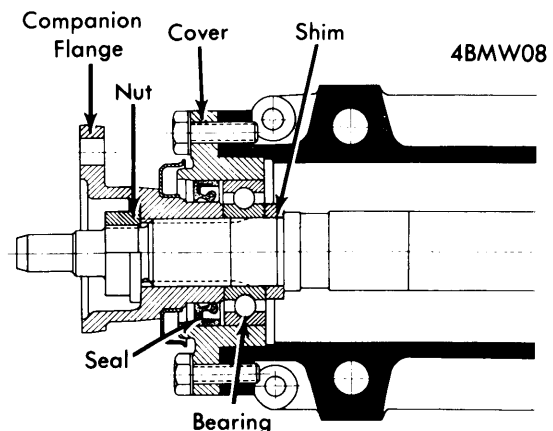

**FRONT PINION SHAFT BEARING ASSEMBLY (LONG NECK HOUSING)**

## 1968-74 BMW INTEGRAL CARRIER (Cont.)

2) Remove drive pinion shaft oil seal then using suitable tools (5109 & 5120) press drive pinion outer bearing cones from housing. **NOTE** — On short neck housing, remove rear bearing cone first. On long neck housing, remove forward bearing cone first.

## REASSEMBLY &amp; ADJUSTMENT

**Differential Assembly** — Reverse disassembly procedure noting the following checks and adjustments.

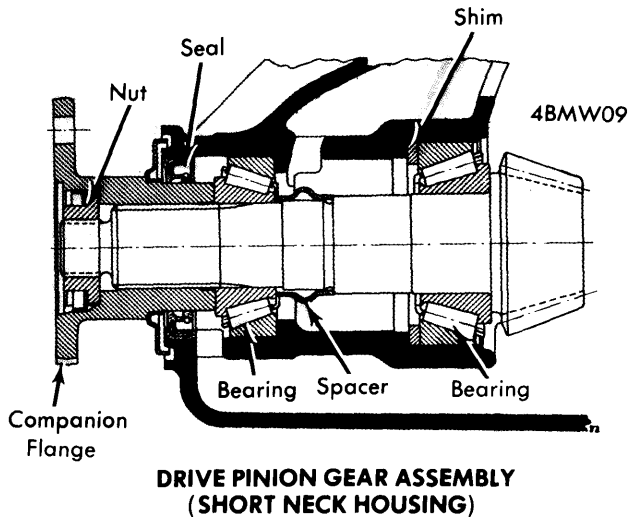

**Drive Pinion Bearing Preload** — 1) If original ring and pinion gear set is being installed, install drive pinion gear using original shim and new collapsible spacer. If a new gear set is being installed determine correct size of shim to use in the following manner: Drive pinion gears may be stamped either "+1,2,3, etc", or "-1,2,3, etc". Compare marks on tapered ends of old and new gears. Subtract the two numbers. In relation to original shim, a plus remainder means a thinner shim is required; a minus remainder means a thicker shim is required.

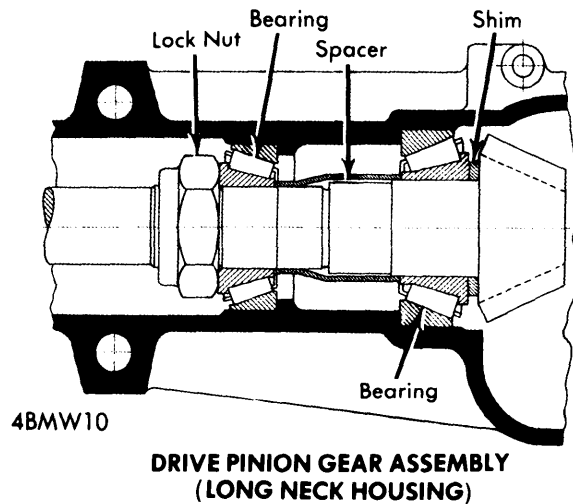

2) Remove then reinstall drive pinion, bearings, and cones, as required, so new shim(s), collapsible spacer, and seal can be installed. **NOTE** — On long neck housing, preload must be established with pinion lock nut before installing front housing cover.

3) Install companion flange and nut (short neck housing), or pinion lock nut (long neck housing) and tighten nut to obtain specified preload. **NOTE** — If preload is exceeded, new collapsible spacer must be installed, and procedure repeated.

**Side-to-Pinion Gear Backlash (Standard Differential)** — With pinion gears and one side gear installed, mount dial indicator to carrier. Force side gear against case, zero indicator then force side gear against pinion gears. With proper shim and thrust washer, backlash should be as specified and preload of all three gears should not exceed 14 ft. lbs. (1.9 mkg). Repeat procedure on opposite side gear, then retain both side gears pressed outward against carrier, so axle drive flange retaining bolts can later be installed.

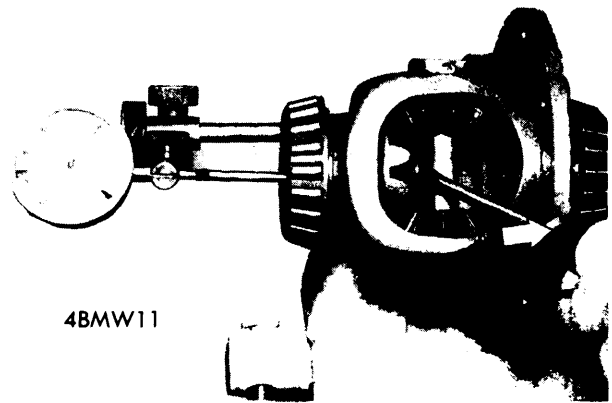

**CHECKING SIDE-TO-PINION GEAR BACKLASH (STANDARD DIFFERENTIAL)**

**Clutch Assembly Endplay (Limited Slip Differential)** — Assemble differential clutch and gear assembly, without ring gear or case. Apply 220 psi (15.5 kg/sq. cm) to one end of assembly. Measure from inner surface of flange to top surface of spacer ring. Measure depth of case. If clutch assembly-to-housing end play is not to specification, adjust by using thicker or thinner inner clutch discs.



**MEASURING CLUTCH ASSEMBLY INSTALLED HEIGHT (WITH PRESSURE APPLIED)**

## 1968-74 BMW INTEGRAL CARRIER (Cont.)

**Checking Pinion Gear Torque (Limited Slip Differential)** – With differential carrier assembled, install axle flanges in carrier. Clamp one flange in vice and using an inch pound torque wrench, turn other flange. If rotating torque of side and pinion gears is not to specification, install thicker or thinner case cover-to-clutch assembly thrust washer.

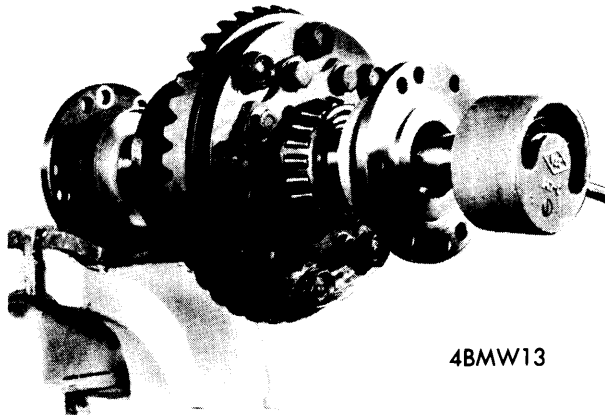

**CHECKING PINION GEAR TORQUE  
(LIMITED SLIP DIFFERENTIAL)**

**Differential Bearing Preload** – With differential carrier installed in housing without ring gear, and with carrier bearing retainer plates installed without shims, thread a bolt in against differential pinion gear shaft. Equally tighten retainer plate bolts until specified bearing preload is obtained. Using

4BMW14

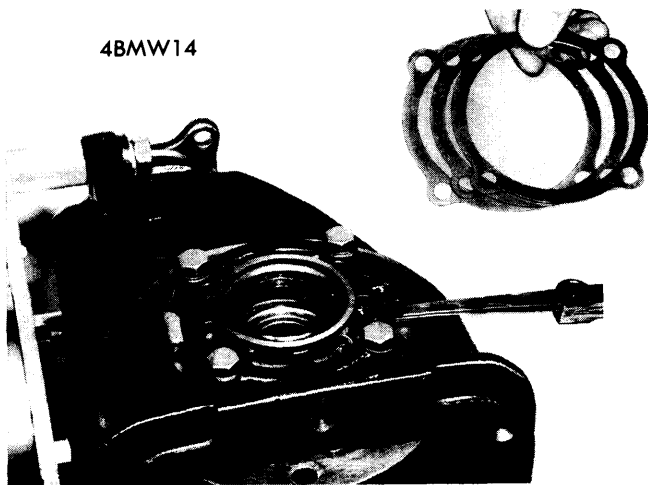

**DIFFERENTIAL BEARING PRELOAD  
SHIM PACK MEASUREMENT**

feeler gauge, check clearance between retainer plate and housing to determine required shim thickness. Take required shims and install them equally under both retainer plates.

**Ring-to-Drive Pinion Gear Backlash** – After establishing differential bearing preload, check ring-to-pinion gear tooth contact pattern. While maintaining established shim thickness, move shims from one retainer plate to the other, as necessary, to obtain proper contact pattern. After setting backlash, complete differential reassembly procedure.

### AXLE ASSEMBLY SPECIFICATIONS

Application	Specification
Axle Shaft End Play .....	.002-.004" (.05-.10 mm)
Axle Drive Flange Runout (Max.).....	.006" (.15 mm)
Differential Pinion Rotating Torque (At Flange)	
Standard (Max.).....	⓪ 14.5 ft. lbs. (2 mkg)
Limited Slip .....	43 INCH lbs. (50 cmkg)
Axle Drive Flange End Play .....	.004"-.006" (.10-.15 mm)
Ring-to-Pinion Gear Backlash	
Short Neck Housing .....	.002-.004" (.05-.10 mm)
Long Neck Housing .....	.003-.005" (.08-.13 mm)
Drive Pinion Gear Bearing Preload	
Short Neck (With Oil Seal).....	27 INCH lbs. (32 cmkg)
Short Neck (Without Oil Seal)....	26 INCH lbs. (30 cmkg)
Long Neck (Without Oil Seal).....	13 INCH lbs. (15 cmkg)
Clutch Assembly-to-Case	
End Play .....	.004-.008" (.10-.20 mm)
Differential Bearing Preload	
Without Oil Seal .....	18-24 INCH lbs. (21-28 cmkg)
⓪ – With one drive shaft installed.	

### TIGHTENING SPECIFICATIONS

Application	Ft. Lbs. (mkg)
Rear Housing Cover Bolts .....	31 (4.3)
Companion Flange Nut .....	108 (15.0)
Front Cover Bolts (Long Neck) .....	⓪ 10 (1.4)
Carrier Bearing Retainer Plate Bolts .....	14 (1.9)
Drive Flange Nut .....	65 (9.0)
Drive Pinion Gear Lock Nut (Long Neck) .....	288 (40.0)
Axle Shaft Castillated Nut .....	216 (29.8)
Ring Gear-to-Carrier Bolts .....	⓪Ⓢ 54 (7.5)

- ⓪ – Using Loctite AVV.
- Ⓢ – Tighten equally in criss-cross pattern.