

TOYOTA PASSENGER, EXC. COROLLA 1200

Celica
Corolla 1600
Corona
Corona MK II

DESCRIPTION

Clutch is a dry, single plate, diaphragm spring type. Clutch actuation is hydraulic, using a firewall mounted master cylinder and a clutch housing mounted slave cylinder. A pre-lubricated clutch release bearing is also used.

REMOVAL & INSTALLATION

CLUTCH ASSEMBLY

Removal — 1) Disconnect positive battery cable. Remove air cleaner and starter. Disconnect accelerator control rod and linkage. On floor shift models, remove shift lever boot and shifter assembly, then cover hole with a clean shop towel.

2) On all except Corona models, drain cooling system and remove radiator hoses. Raise vehicle and support at front and rear with safety stands. If equipped, remove protective cover from under engine.

3) Remove clutch slave cylinder but do not disconnect hydraulic line. Disconnect exhaust pipe support bracket from transmission, and disconnect exhaust pipe from exhaust manifold. On column shift models, disconnect shift linkage at transmission. On all models, disconnect speedometer cable and electrical leads at transmission.

4) Disconnect drive shaft at differential and slide from transmission. Install a suitable plug in transmission extension housing to prevent oil spillage. Remove protective cover from clutch housing, if equipped.

5) Support transmission with a floor jack and remove rear support crossmember. Lower jack and remove bolts securing transmission to engine, then remove transmission toward rear of vehicle. Remove bolts attaching clutch assembly to flywheel and remove clutch assembly.

Installation — To install, reverse removal procedure and note the following: Use a suitable aligning tool to center clutch disc on flywheel. Tighten clutch pressure plate attaching bolts alternately and evenly in a diagonal progression. With transmission installed, adjust clutch.

CLUTCH MASTER CYLINDER

Removal — Remove cotter pin and clevis pin connecting master cylinder push rod to clutch pedal, then disconnect push rod. Disconnect hydraulic line from cylinder, remove cylinder attaching nuts at firewall, and remove cylinder from vehicle.

Installation — To install, reverse removal procedure and note the following: When installing master cylinder, make sure rubber boot hole faces downward. Adjust pedal height and free play, and bleed hydraulic system.

CLUTCH SLAVE CYLINDER

Removal — Raise front of vehicle and support with safety stands. If equipped, remove protective cover under engine.

Remove return spring and disconnect hydraulic line. Back off push rod and remove slave cylinder attaching nuts and slave cylinder.

Installation — To install, reverse removal procedure and note the following: After installing slave cylinder, adjust free play at release lever and bleed hydraulic system.

CLUTCH RELEASE BEARING

Removal — With transmission removed, check release bearing for freedom of rotation with bearing still installed on hub. To remove, disconnect spring clips from bearing collar and slide bearing off transmission input shaft. Use a press to remove and install bearing on collar.

Installation — Slide bearing and collar over transmission input shaft and secure to release lever with new retaining clips. Apply grease to diaphragm spring contact points before installing transmission.

PILOT BEARING

Removal — With transmission and clutch assembly removed, check pilot bearing in crankshaft for roughness or noise. If required, remove bearing using a suitable puller (09303-35010).

Installation — Apply grease to new bearing and install into crankshaft using a suitable driver (09304-30012 for Corona models, or 09304-12011 for all others).

OVERHAUL

CLUTCH MASTER CYLINDER

Disassembly, Corona Mk II — With cylinder removed from vehicle, mount unit in a vise, taking care not to damage reservoir mounting surface. Remove bolt retaining reservoir to cylinder body, and separate reservoir from body. Remove cylinder end cap and snap ring and remove all internal parts.

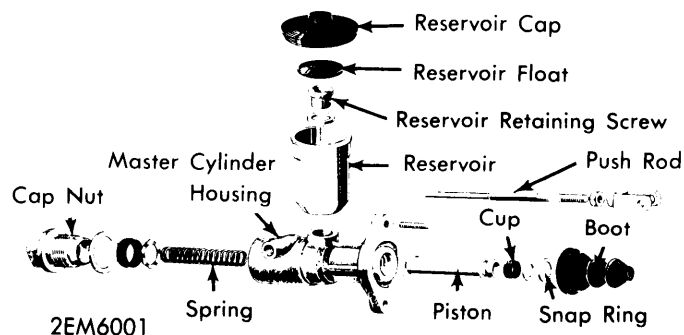

MASTER CYLINDER ASSEMBLY (CORONA MK II)

Inspection, Corona Mk II — Inspect cylinder and piston for wear or scores, replace as necessary. Check spring for weakening and reservoir for damage. Ensure vent hole in reservoir cap is clear. Check piston cup spacer for wear, damage or distortion. **NOTE** — Manufacturer recommends replacing seals whenever cylinder has been disassembled.

Reassembly, Corona Mk II — 1) Dip cylinder cups in clean brake fluid or coat with rubber grease before assembly. Install push rod in cylinder body and secure with snap ring, then install rubber boot.

Clutches

TOYOTA PASSENGER, EXC. COROLLA 1200 (Cont.)

2) Install cylinder cup on piston and insert in cylinder from front end. Install spacer and cup. Install spring seat on spring, install into cylinder, then install and tighten end cap. Position reservoir on cylinder, and install and tighten bolt.

Disassembly (All Others) — With cylinder removed from vehicle, clamp unit in a vise, taking care not to damage cylinder. Remove reservoir, snap ring and push rod. Remove cylinder cap and snap ring, then remove piston, cup, and remaining parts. Disassemble piston by prying up spring retainer and disconnect retainer from piston.

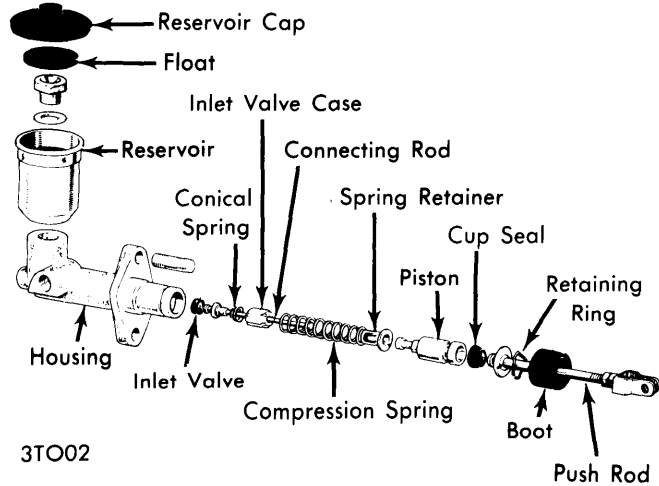

**MASTER CYLINDER ASSEMBLY
(CORONA, CELICA & COROLLA 1600)**

Inspection (All Others) — Clean all parts in clean brake fluid. Check master cylinder bore and piston for wear, damage, or scores, replace as necessary. Check compression spring for distortion or weakening, and reservoir for damage. Make sure vent hole in reservoir cap is open.

Reassembly (All Others) — Dip cylinder cups in clean brake fluid or coat with rubber grease before assembly. Assemble piston assembly in reverse order of disassembly. Install piston assembly, push rod, and reservoir into master cylinder.

CLUTCH SLAVE CYLINDER

Disassembly — With slave cylinder removed from vehicle, remove rubber boot and push rod. Remove piston and cups, then remove bleeder screw.

Inspection — Thoroughly clean all parts with clean brake fluid and inspect for wear or damage. *NOTE* — *Manufacturer recommends replacing seals each time slave cylinder is disassembled.*

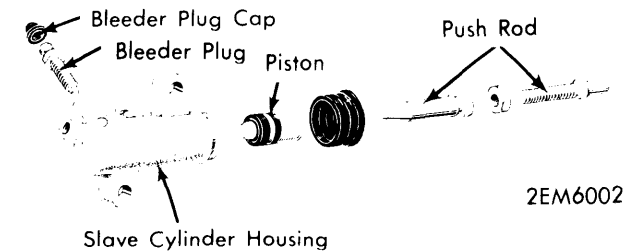

**SLAVE CYLINDER COMPONENTS — TYPICAL
(CORONA MK II SHOWN)**

Reassembly — Soak all parts in clean brake fluid before assembly. Install seals on piston, then install piston into cylinder. Install rubber boot and push rod. Install bleeder screw and cap.

ADJUSTMENT

PEDAL HEIGHT

Adjust pedal stop bolt at top of pedal assembly until specified pedal height is obtained. Height is measured from floor mat to top of pedal pad.

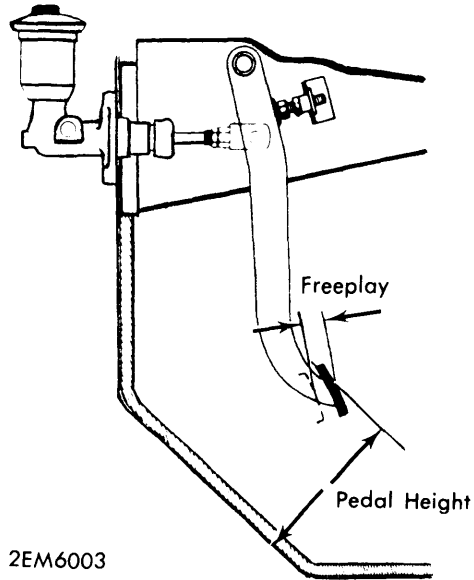

**PEDAL HEIGHT & FREEPLAY
MEASURING POINTS**

Pedal Height Specifications

Application	Height
Celica	6.3" (160 mm)
Corolla 1600	6.3-6.8" (160-170 mm)
Corona	6.3-6.8" (160-170 mm)
Corona Mk II	6.2-6.6" (153-163 mm)

MASTER CYLINDER PUSH ROD FREE PLAY

To obtain specified free play between pedal push rod and master cylinder piston, loosen lock nut on push rod and adjust rod until specified free play is obtained.

Master Cylinder Push Rod Free Play Specifications

Application	Free Play
Celica04-.12" (1.0-3.0 mm)
Corolla 1600	0-.02" (0-.05 mm)
Corona04-.28" (1.0-7.0 mm)
Corona Mk II02-.12" (.5-3.0 mm)

CLUTCH FORK FREE PLAY

Clutch fork free play determines amount of clearance between clutch release bearing and clutch. To obtain specified free play, loosen lock nut on slave cylinder push rod and screw push rod in or out until specified free play is obtained.

TOYOTA PASSENGER, EXC. COROLLA 1200 (Cont.)

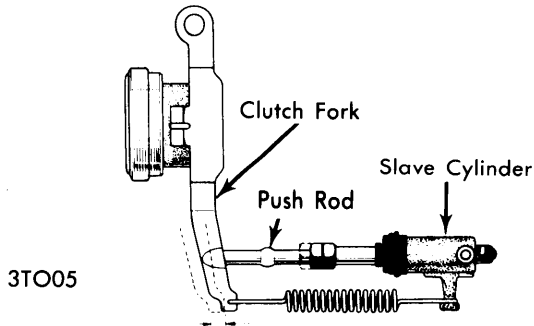

MEASURING CLUTCH FORK FREE PLAY

Clutch Fork Free Play Specifications

Application	Free Play
Celica079-.138" (2.0-3.5 mm)
Corolla 16001-.138" (2.5-3.5 mm)
Corona079-.118" (2.0-3.0 mm)
Corona Mk II079-.138" (2.0-3.5 mm)

PEDAL FREE PLAY

Pedal free play is total of clutch fork free play and master cylinder push rod free play, and is measured at pedal pad. If other measurements are to specification, pedal free play should be as specified in table.

Pedal Free Play Specifications

Application	Free Play
Celica, Corona, Corolla 1600	1.0-1.75" (25-45 mm)
Corona Mk II	1.4-2.0" (35-50 mm)

HYDRAULIC SYSTEM BLEEDING

- 1) Raise vehicle and support with safety stands. Make sure clutch master cylinder reservoir is full of fluid. Remove bleeder screw cap and loosen bleeder screw. Place a finger on vent hole of bleeder screw and push clutch pedal to bottom of stroke three or four times.
- 2) With pedal fully depressed, remove finger and allow air to vent out. Repeat procedure three or four times or until pressure is felt. Install a flexible hose on bleeder screw and insert free end into a container partially full of brake fluid.
- 3) Push pedal to bottom of stroke, loosen bleeder screw, and allow fluid to bleed into container. Tighten bleeder screw and release clutch pedal. Repeat procedure until air bubbles are no longer seen in container, then close screw on a down stroke of pedal. Check system for leaks and fill master cylinder.

TIGHTENING SPECIFICATIONS

Application	Ft. Lbs. (mkg)
Clutch Cover-to-Flywheel	
Carina	11-12 (1.5-1.6)
Corolla 1600	11-16 (1.5-2.2)
Corona & Corona Mk II	7-12 (.97-1.6)
Clutch Housing-to-Engine (All).....	35-50 (4.9-6.9)