

Pantera Engines

351" V8

GENERAL SPECIFICATIONS										
Year	Displ.		Carburetor	HP at RPM	Torque (Ft. Lbs. at RPM)	Compr. Ratio	Bore		Stroke	
	cu. ins.	cc					in.	mm	in.	mm
1974	351	5752	4 Bbl.	8.0-1	4.00	101.6	3.50	88.9

ENGINE IDENTIFICATION

Engine is identified by a tag located under ignition coil attaching bolt. Tag has codes which identify C.I.D., model year, calendar year, month of production, and change level number.

Engine Identification Codes

351 C 73 1

3 E 623 AG

1st Row

- 351 — 351" engine.
- C — Plant code (Cleveland).
- 73 — Model year.
- 1 — Change level.

2nd Row

- 3 — Year of production.
- E — Month of Production.
- 623 AG — Engine Code (351" C 4-Bbl.).

ENGINE REMOVAL

- 1) Engine and transaxle are removed as a unit. Remove rear deck lid and luggage compartment floor. Disconnect battery ground cable and remove engine cover from vehicle.
- 2) Disconnect tube and lines from air cleaner and remove air cleaner. Remove trim panel and engine access panel from behind seats. Remove alternator and drive belt.
- 3) Disconnect compressor clutch lead wire. Remove compressor attaching bolts and compressor drive belt. Remove pressure cap from coolant supply tank. Raise vehicle on a hoist.
- 4) Remove lower bolt holding compressor bracket to engine. Disconnect hose from water pump and drain cooling system. Remove bolts attaching carburetor heat riser to exhaust manifold. Separate exhaust manifolds from cylinder heads and move clear of engine.
- 5) Disconnect power cable from starter and engine mounting bolts from chassis brackets. Disconnect fuel tank-to-fuel pump line at pump and plug line. Lower vehicle and remove top two bolts attaching compressor bracket to engine.
- 6) Remove compressor bracket nut and timing pointer. Position compressor clear of engine. Disconnect lead from PVS valve thermo-switch. Disconnect heater hoses at engine. Remove flex hose between engine and supply tank.
- 7) Disconnect accelerator cable at carburetor and remove cable bracket. Disconnect power vacuum hose at intake manifold and remove it from the retainer. Disconnect wires from coil, temperature and oil pressure sending units.
- 8) Disconnect transaxle vent line from crossmember. Remove attaching bolts and crossmember. Remove eight bolts and nuts holding axle shaft to transaxle flanges. Disconnect shift linkage from transaxle rod at "U" joint.

- 9) Remove back-up light switch wires from shift linkage box on left side of transaxle. Disconnect speedometer cable. Remove condenser assembly from back panel and position clear of engine.

- 10) Disconnect rear mount brackets from chassis. Remove nut attaching ground strap to transaxle. Disconnect hydraulic line from clutch slave cylinder. Install lifting eyes above exhaust manifolds and attach suitable lifting sling.

- 11) Carefully lift engine while guiding transaxle up and away from rear panel. Remove starter from engine. Remove bolts attaching adapter plate to clutch housing. Remove six bolts attaching clutch housing to engine and separate transaxle from engine.

INTAKE MANIFOLD

- 1) Open rear deck lid and remove luggage compartment floor. Remove engine cover and air cleaner. Disconnect high tension lead and wires from coil. Disconnect wires from accelerator solenoid and temperature sending unit.
- 2) Remove distributor cap and spark plug wire assembly. Disconnect carburetor fuel inlet line and remove heater hoses. Remove vacuum control valve and bracket. Disconnect PCV hose at right rocker arm cover.
- 3) Disconnect vacuum lines from intake manifold. Remove bolts connecting vacuum outlet to left rocker cover (if equipped). Pull vacuum line from distributor and remove distributor.
- 4) Remove fuel line at carburetor. Disconnect heater hoses and position clear of manifold. Remove vacuum control valve and bracket. Disconnect PCV hose at right rocker arm cover and vacuum lines from manifold. Remove bolts attaching vacuum outlet to left rocker arm cover (if equipped).
- 5) Remove distributor and vacuum lines. Disconnect accelerator cable and remove carburetor. Remove attaching bolts and lift off manifold, discard manifold gasket and seals.

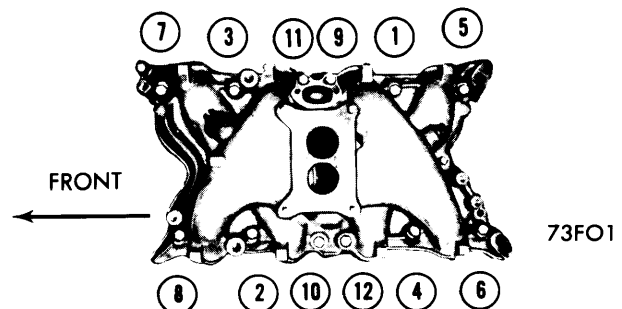

INTAKE MANIFOLD TIGHTENING SEQUENCE

351" V8 (Cont.)

Installation — Apply suitable oil resistant sealer at four junction points of seals and gaskets. Position front and rear seals on cylinder block and new gaskets on heads. Make sure that holes in gaskets are aligned with holes in cylinder head. Position gaskets so interlocked with seal tabs. Lower manifold on engine and check for correct positioning of gaskets and seals before installing bolts. Install bolts and tighten to specifications (see illustrations for sequence). Run engine until normal operating temperature is reached, then retorquing bolts.

steps. Retorquing of heads after engine operation is not necessary. Install remaining components in reverse of removal procedures.

CYLINDER HEAD

Removal — 1) With intake manifold removed, remove thermostat and housing from block. Disconnect water hose from expansion tank. Remove PCV valve from rocker cover. Remove rocker covers and oil pressure sending unit wire.

2) Remove rocker arm bolts, oil deflectors, rocker arms and push rods in proper order for reassembly. Disconnect dipstick tube and move aside. Remove cylinder heads and discard gasket.

Installation — Place new cylinder head gasket over dowels in block. Place heads in position and torque bolts in three

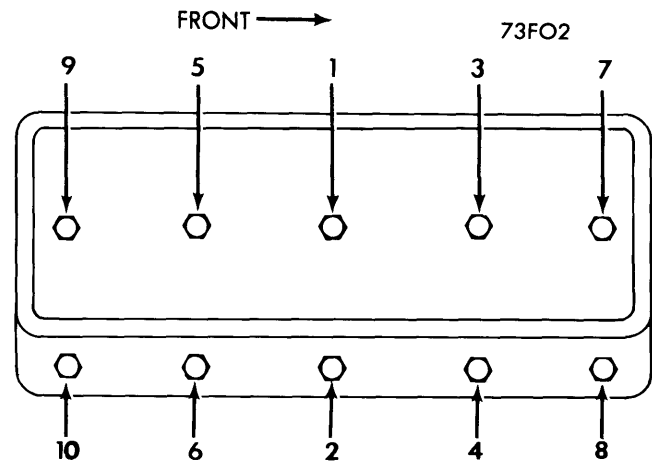

CYLINDER HEAD TIGHTENING SEQUENCE

VALVES							
Engine & Valve	Head Diam. In. (mm)	Face Angle	Seat Angle	Seat Width In. (mm)	Stem Diameter In. (mm)	Stem Clearance In. (mm)	Valve Lift In. (mm)
351" C Int.	2.032-2.050 (51.61-52.07)	44°	45°	.060-.080 (1.52-2.03)	.3416-.3423 (8.68-8.69)	.001-.0027 (.025-.069)	.481 (12.22)
Exh.	1.705-1.715 (43.31-43.56)	44°	45°	.070-.090 (1.78-2.29)	.3411-.3418 (8.66-8.68)	.0015-.0032 (.038-.081)	.490 (12.45)

VALVE ARRANGEMENT

E-I-E-I-E-I-E-I (Left bank, front to rear).
I-E-I-E-I-E-I-E (Right bank, front to rear).

VALVE SPRING INSTALLATION

Spring ends must be square within $\frac{5}{64}$ ". Install springs with damper (closed) coil end down toward cylinder head. If damper spring used, end of damper spring coil must be 135° counterclockwise from coil end of valve spring.

VALVE GUIDE SERVICING

To ream guides for installation of valves with oversize stems, always use reamers in sequence and reface valve seat after valve guide is reamed. Reamers are furnished .003" oversize with standard diameter pilot; .015" oversize reamer with .003" oversize pilot; and .030" oversize reamer with .015" oversize pilot.

VALVE SPRING INSTALLED HEIGHT

Valve spring installed height is $1\frac{13}{16}$ - $1\frac{27}{32}$ ". Measure height from surface of cylinder head pad to underside of spring retainer. If height is greater than specified, install .030" spacer on head under spring to bring height within limits.

CAUTION — Install spacers only if necessary and do not use more than two spacers. More than two spacers will overstress springs and overload camshaft lobes.

VALVE STEM OIL SEALS

Cup or umbrella type seals used on all valves. Install seals with cup side down over valve guide.

VALVE SPRINGS			
Engine	Free Length In. (mm)	PRESSURE Lbs. @ In. (kg @ mm)	
		Valve Closed	Valve Open
351" C	2.05 (52.07)	85-95@1.82 (38.6-43.1@46.2)	271-299@1.32 (122.9-135.6@33.5)

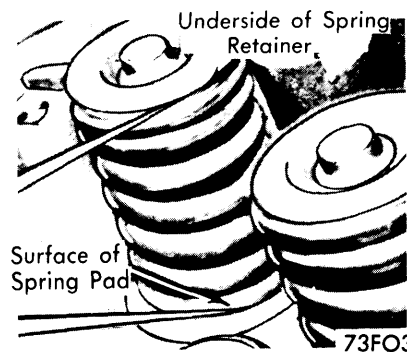

MEASURING VALVE SPRING HEIGHT

351" V8 (Cont.)

HYDRAULIC VALVE LIFTER ASSEMBLY

Two different types of lifters are used (Type I and Type II). Lifters are serviced as assemblies only, parts are not interchangeable. Always check rocker arm-to-valve stem clearance before concluding a noisy lifter is defective. After cleaning and reassembling lifters, they should be tested for leak down rate. Use lifter tester according to directions of manufacturer. Leak down rate is 5-50 seconds measured at 1/16" plunger travel.

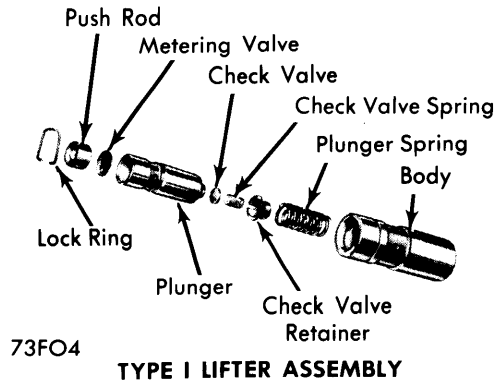

73FO4
TYPE I LIFTER ASSEMBLY

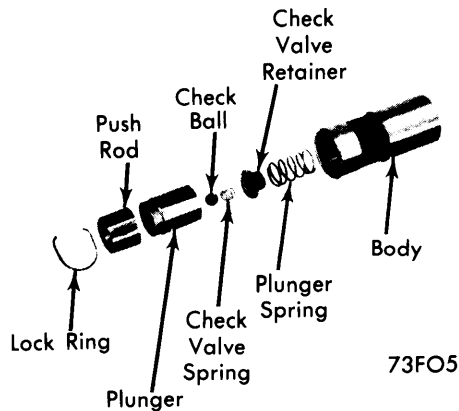

73FO5
TYPE II LIFTER ASSEMBLY

HYDRAULIC VALVE LIFTER ADJUSTMENT

Repeated valve (seat and face) reconditioning operations will decrease valve stem to rocker arm clearance to point that if compensation is not made, valve lifters will cease to function. To compensate for any dimensional changes in valve mechanism, a .060" shorter or a .060" longer replacement

push rod is available. To determine whether or not a longer or shorter push rod is necessary, clearance between rocker arm and valve stem must be checked. **NOTE — Valve lifter must be completely collapsed when checking valve clearance.** Use suitable tool and slowly collapse valve lifter until plunger is bottomed. Hold lifter down while checking clearance. Procedure for checking valve clearances is as follows:

- 1) Rotate crankshaft until No. 1 piston is at TDC (point "A", see illustration) after compression stroke as indicated by timing mark on crankshaft damper and pointer. Make a chalk mark on damper 180° (point "B") from TDC mark. Make a chalk mark on damper 90° (point "C") counterclockwise from TDC mark.
- 2) With damper at position "A", check following valves: intake numbers 1-4-8 and exhaust numbers 1-3-7. Valve lifter clearance is .100-.150".
- 3) Rotate crankshaft 180° (1/2 turn) clockwise from position "A" so that position "B" is opposite pointer. Check following valves: intake numbers 3-7 and exhaust numbers 2-6.
- 4) Rotate crankshaft 270° (3/4 turn) clockwise from position "B" so that position "C" is opposite pointer. Check following valves: intake numbers 2-5-6 and exhaust numbers 4-5-8.

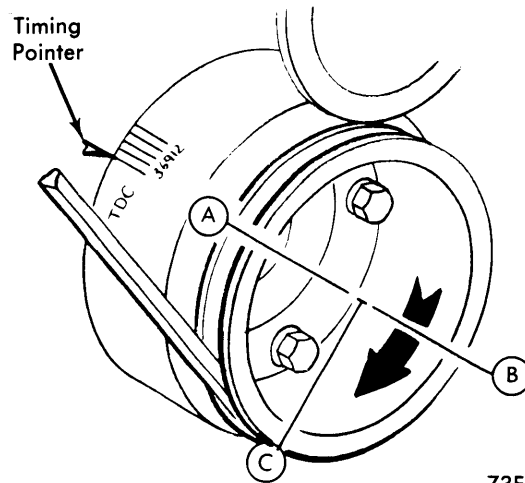

73FO6

POSITIONS FOR CHECKING VALVE CLEARANCE

Engine	PISTONS, PINS, RINGS					
	PISTONS	PINS		RINGS		
	① Clearance In. (mm)	Piston Fit In. (mm)	Rod Fit In. (mm)	Rings	End Gap In. (mm)	Side Clearance In. (mm)
351" C	.0014-.0022 (.036-.056)	.0002-.0004 (.005-.010)	Press Fit	1	.010-.020 (.254-.508)	.002-.004 (.051-.102)
				2	.010-.020 (.254-.508)	.002-.004 (.051-.102)
				3	.015-.055 (.381-1.397)	Snug

① — Measured at piston pin bore centerline, 90° to pin bore.

351" V8 (Cont.)

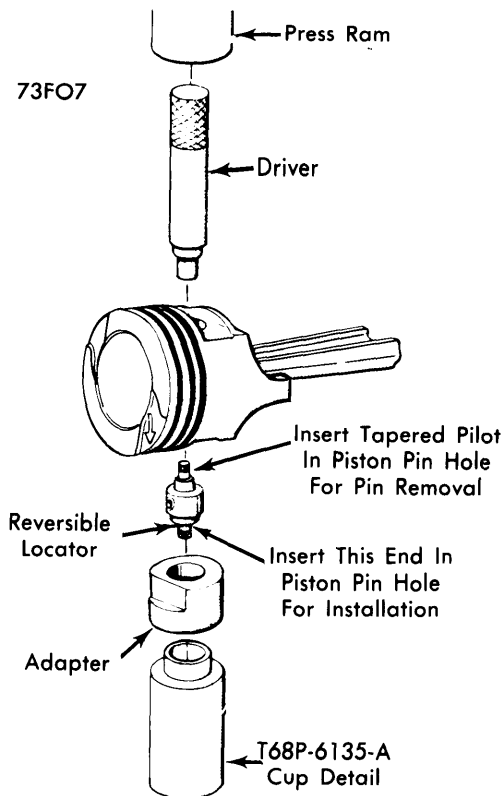

PISTON PIN INSTALLATION

PISTON PIN REPLACEMENT

Piston pins are removed and replaced using an arbor press, pilots and driver (see illustration). Measure pin and connecting rod diameters to determine proper fit.

FITTING PISTONS

Measure piston at centerline of piston pin bore 90° to pin bore axis. Measure cylinder bore at right angles to centerline of crankshaft, below ring travel. Piston clearance should be within specifications.

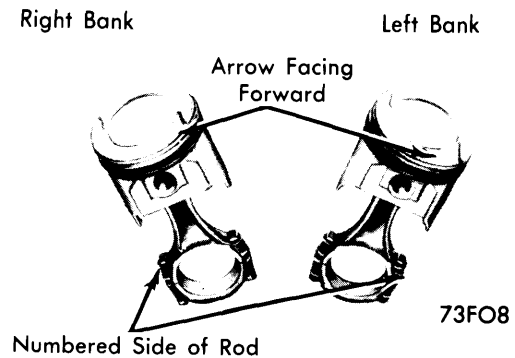

PISTON & ROD LOCATING MARKS

CRANKSHAFT MAIN & CONNECTING ROD BEARINGS

Engine	MAIN BEARINGS				CONNECTING ROD BEARINGS		
	Journal Diam. In. (mm)	Clearance In. (mm)	Thrust Bearing	Crankshaft End Play In. (mm)	Journal Diam. In. (mm)	Clearance In. (mm)	Side Play In. (mm)
351" C	2.7484-2.7492 (69.81-69.83)	.001-.0015 (.025-.038)	No. 3	.004-.008 (.102-.203)	2.3103-2.3111 (58.68-58.70)	.0011-.0015 (.028-.038)	.010-.020 (.254-.508)

OIL PAN

Removal — To remove oil pan it is necessary to remove engine/transaxle assembly from vehicle. Separate transaxle from engine. Remove oil pan and gasket from block.

Installation — Coat engine block and two piece gasket with sealer. Place front and rear seals on front cover and rear main bearing cap so ends lap over gaskets. Install oil pan and tighten bolts from center outward.

MAIN & CONNECTING ROD BEARINGS

Use Plastigage method of determining bearing clearance. Be sure that all bearing caps are installed in their original locations. Bearing inserts are available in .001", .002", .010", .020", .030" and .040" undersizes. Rear main bearing cap mating surface is coated with oil resistant sealer. Do not use sealer forward of oil slinger groove.

If bearing clearance using standard size bearing inserts is excessive, a .001" or .002" undersize bearing half may be used in combination with standard size bearing half. If .002" under-

size bearing half is used on more than one journal, they may be positioned in the cylinder block rather than the bearing cap. If standard and .002" undersize combination do not bring clearance to within specified limits, the crankshaft will have to be refinished and undersize bearings installed.

THRUST BEARING ALIGNMENT

Install all bearing caps except thrust bearing cap and tighten. Install thrust bearing cap with bolts finger tight. Pry crankshaft to front of engine, then pry thrust cap to rear of engine. While holding crankshaft forward, tighten bearing cap bolts. Check crankshaft endplay.

REAR MAIN BEARING OIL SEAL

Complete seal is replaced without removing crankshaft as follows:

1) Loosen all main bearing bolts, lowering crankshaft not to exceed 1/32". Remove rear main bearing cap, remove seal half from cap. Remove upper seal half with suitable tool, being careful not to scratch or damage crankshaft journal or seal surfaces.

351" V8 (Cont.)

2) Remove oil seal retaining pin from bearing cap (if equipped). Discard pin. Dip seal halves in engine oil. Install upper seal in groove with undercut side of seal toward front of engine, by rotating it on seal journal until $\frac{3}{8}$ " protrudes below parting surface (see illustration). Tighten main bearing cap bolts.

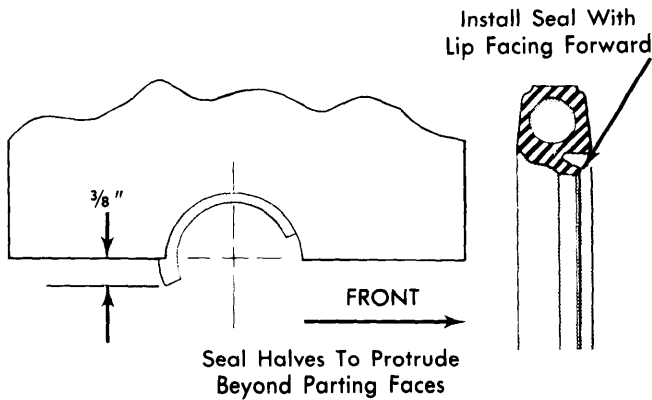

73FO9

REAR MAIN BEARING OIL SEAL

3) Install lower seal in rear bearing cap with undercut side towards front of engine, allowing seal to protrude $\frac{3}{8}$ " above parting surface.

4) Apply thin coating of oil resistant sealer to cap at rear of top mating surface. **NOTE** - Do not apply sealer to area forward of side seal groove. Install main bearing cap and tighten bolts.

ENGINE FRONT COVER

Removal - With engine/transaxle assembly removed from vehicle, using suitable pullers remove crankshaft pulley and vibration damper. Remove timing pointer from engine. Unscrew attaching bolts and remove timing cover and water pump as an assembly.

Installation - Coat gasket and block with sealer and position gasket on cylinder block alignment dowels. Place front cover over dowels. Coat threads of attaching bolts with oil resistant sealer. Install timing pointer and tighten bolts. Install remaining components, using a mixture of white lead and engine oil on crankshaft for damper installation.

FRONT COVER OIL SEAL

Removal - Install suitable seal puller tool (No. T70P-6B070-B), and tighten through bolts to position seal puller under seal flange. Alternately tighten four puller bolts to remove oil seal.

Installation - Coat seal with grease and press into front cover using suitable tool (No. T70P-6B070-A). Check seal to make sure that seal has fully seated.

TIMING CHAIN

Inspection - With front cover removed, remove crankshaft front oil slinger. Rotate crankshaft in counterclockwise direction to take up slack on left side of chain. Establish reference point on block (left side of chain) and measure distance to chain. Rotate crankshaft clockwise to take up slack on right side of chain. Force left side of chain out with fingers and measure distance between reference point and chain. Deflection is difference between two measurements. If deflection exceeds .500", replace timing chain and sprockets.

Removal & Installation - Crank engine until timing marks are positioned properly (see illustration). Remove camshaft sprocket cap screw, washers and fuel pump eccentric. Slide both sprockets and timing chain forward and remove them as an assembly. To install, position timing chain on sprockets with timing marks aligned (see illustration). Slide sprockets and timing chain onto engine as an assembly. Install fuel pump eccentric, washers and sprocket cap screw. Tighten bolt and oil timing chain.

CAMSHAFT

1) With engine/transaxle assembly removed from vehicle, remove timing cover. Disconnect fuel pump outlet line and remove fuel pump. Remove oil slinger from crankshaft.

2) Rotate engine until timing marks are aligned. Remove camshaft sprocket screw and two piece fuel pump eccentric. Slide both sprockets and timing chain off shafts.

3) Remove intake manifold and rocker arm covers. Loosen rocker arm fulcrum bolts and rotate rocker arm to the side. Remove push rods and set aside in proper order for reassembly.

4) Using suitable tool (T70P-14151) remove valve lifters and set aside in assembly order. Remove camshaft thrust plate and carefully pull camshaft out front of engine. To install, reverse removal procedures.

CAMSHAFT BEARINGS

With crankshaft, connecting rods and camshaft removed, remove rear bearing plug and drive out camshaft bearings. Using suitable tool (T65L-6250-A), select correct expanding collet for bearing being installed. Pull bearing into place. When installing front bearing, insert tool from rear of block and pull bearing into block until bearing is .040-.060" below front face of engine block. Camshaft bearings are available in standard and .015" undersize journal diameters. Bearings are not interchangeable from one bore to another.

CAMSHAFT END THRUST

Camshaft end play is controlled by thrust plate located behind timing gear. Loosen all rocker arms to remove spring load from camshaft. Place a dial indicator on end of camshaft and measure end play. If end play is excessive, replace thrust plate.

CAMSHAFT			
Engine	Journal Diam. In. (mm)	Clearance In. (mm)	Lobe Lift In. (mm)
351" C No. 1	2.1243 (53.96)	.001-.003 (.025-.076)	Int. .278 (7.06)
	2		Exh. .283 (7.19)
3	2.0510 (52.10)		
4	2.0360 (51.71)		
5	2.0210 (51.33)		

351" V8 (Cont.)

CAM LOBE LIFT

Check lift of each camshaft lobe in consecutive order as follows:

- 1) Remove rocker arms and make sure each push rod is in valve lifter socket. Install dial indicator so ball socket adapter of indicator rests on end of push rod and in same plane as push rod movement.
- 2) With an auxiliary starter switch connected to starter solenoid and ignition switch off, bump crankshaft until tappet is on base circle of camshaft lobe. This is push rods lowest point.
- 3) Zero dial indicator and continue to rotate crankshaft until push rod is in fully raised position (highest indicator reading). Compare total lift from indicator readings with specifications.
- 4) To check accuracy of dial indicator readings, continue to rotate crankshaft until indicator reads zero. If lift on any lobe is .005" less than specifications, valve lifters are operating on worn lobes.

VALVE TIMING

With sprockets correctly positioned in timing chain, slide sprockets on crankshaft and camshaft so timing marks are aligned (see illustration).

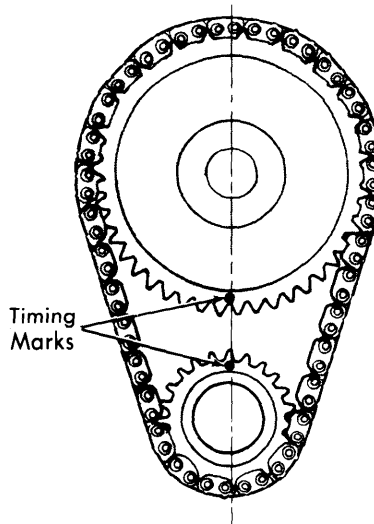

73FO10

VALVE TIMING MARKS

ENGINE OILING

Crankcase Capacity — 5 qts. (including filter).

Oil Filter — Full-flow, replaceable type.

Normal Oil Pressure — 45-74 psi at 2,000 RPM.

Pressure Regulator Valve — Non-adjustable.

ENGINE OILING SYSTEM

Force feed with rotor type oil pump. All oil from pump flows through full flow oil filter before entering engine. From oil filter oil flows to main oil gallery located on right side of camshaft and lubricates engine components as follows:

Main Bearings — Oil from main gallery enters main bearings through drilled passages in block.

Camshaft Bearings — Passages are drilled from each main bearing to each camshaft bearing.

Connecting Rod Bearings — Crankshaft is drilled from main bearings to connecting rod bearings.

Valve Lifters, Push Rods — Oil passages drilled from main oil gallery to each lifter gallery. Oil hole in valve lifter is indexed to lifter oil gallery and oil flows into lifter. Oil from lifter is metered through disc metering valve and flows up hollow push rod. Drilled hole in push rod is indexed to hole in rocker arm and oil lubricates the upper valve train and bearings. Excess oil is returned to oil pan through drain back holes at each end of cylinder head and block.

Timing Chain — Oil is forced through a drilled passage from oil pump intermediate shaft to groove in thrust plate and passes around camshaft. It then flows through two grooves in timing chain sprocket and is deflected onto the timing chain.

OIL PUMP

Removal — With oil pan removed, remove oil pump attaching bolts and withdraw pump complete with pickup tube, screen, gasket and intermediate drive shaft.

Disassembly — 1) Remove pickup tube from pump. Remove cover and take out inner and outer rotors. Remove cotter pin and drill a small hole and insert a metal screw in pressure relief cap. Pull out cap and remove spring and plunger.

2) Clean and inspect all parts for wear or damage. Using a feeler gauge, measure rotor clearances. Rotors must be replaced as an assembly.

Assembly — Oil all parts thoroughly. Install oil pressure relief valve plunger, spring, new cap and cotter pin. Install inner and outer rotors with identification marks facing pump cover. Position cover and tighten attaching screws. Install pickup tube and screen. Prime pump with oil by pouring oil into pump while rotating drive shaft.

Installation — 1) Place intermediate drive shaft in engine block with shaft firmly seated in distributor socket. Position shaft stop so that it just touches roof of crankcase.

Pantera Engines

351" V8 (Cont.) ENGINE OILING (Cont.)

2) With a new gasket, install intermediate shaft and pump. Install and tighten attaching bolts. Make sure oil pump screen is parallel with oil pan mounting flange.

CAUTION — Do not force pump into position if it will not readily seat. Rotate drive shaft until it has seated in distributor drive shaft hex and then tighten attaching bolts.

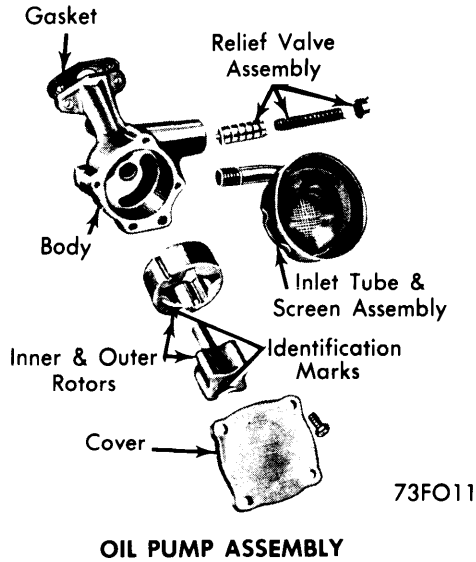

Oil Pump Specifications

Application	Clearance (In.)
Outer Rotor-to-Body006-.013
Rotor End Play001-.004
Shaft-to-Body0015-.0029
Relief Valve-to-Bore0015-.0029
Relief Valve Spring	23.6-24.6 lbs. @ 1.370

TIGHTENING SPECIFICATIONS

Application	Ft. Lbs. (mkg)
Cylinder Head	
Step 1	55 (7.60)
Step 2	75 (10.73)
Step 3	95-105 (13.13-14.52)
Oil Pan	
1/4" Bolts	7-9 (.97-1.24)
5/16" Bolts	11-13 (1.52-1.80)
Intake Manifold	① 21-25 (2.90-3.46)
Exhaust Manifold	12-22 (1.66-3.04)
Flywheel	75-85 (10.37-11.75)
Main Bearing Caps	
3/8" Bolts	35-45 (4.84-6.22)
1/2" Bolts	95-105 (13.13-14.52)
Connecting Rod Caps	40-45 (5.53-6.72)
Damper or Pulley	35-50 (4.84-6.91)
Front Cover	14-20 (1.94-2.77)
Camshaft Sprocket	40-45 (5.53-6.22)
Oil Pump Cover	9-12 (1.24-1.66)
Rocker Arm Bolts	18-25 (2.49-3.46)
① — 3/8" bolts 27-33, 1/4" bolts 6-9 ft. lbs.	

ENGINE COOLING

Thermostat — Opens at 185-192°F, fully open at 210-216°F.

Cooling System Capacity — 25.5 qts.

WATER PUMP

1) Raise vehicle on a hoist and partially drain cooling system. Lower vehicle and install protective seat covers. Remove interior trim panel and engine access covers.

2) Loosen alternator and remove drive belt. Remove water pump pulley. Remove bolt attaching alternator arm to water pump. Disconnect vacuum hoses and wires from EPVS valve and remove valve from pump. Disconnect lower hose and remove pump from engine. To install, reverse removal procedures.