

## 230 4 CYLINDER

GENERAL SPECIFICATIONS										
Year	Displ.		Carburetor	HP at RPM	Torque (Ft. Lbs. at RPM)	Compr. Ratio	Bore		Stroke	
	cu. ins.	cc					in.	mm	in.	mm
1974	140.8	2307	1x1-Bbl.	85@4800	128@2500	8-1	3.69	93.75	3.29	83.6

### ENGINE IDENTIFICATION

Engine code is determined by first six digits of engine identification number, stamped on left side of engine block.

Model	Type	Engine Code
230.....	115.017.....	115.951

### ENGINE REMOVAL

*NOTE* — Engine and transmission must be removed as complete assembly.

1) Remove hood and disconnect ground cable from battery. Disconnect hoses and transmission oil cooler lines from radiator and remove radiator. Remove air cleaner and disconnect heater hoses.

2) Disconnect all vacuum, fuel and oil lines from engine and transmission. On vehicles with air conditioning, remove compressor from engine and set aside with hoses connected. Disconnect all electrical leads and cables from engine and transmission.

3) Disconnect linkage and choke cable from carburetor, gearshift linkage from transmission, and exhaust pipe from manifold. Loosen steering relay arm and move it downward together with center tie rod and steering shock absorber.

4) Disconnect engine shock absorber from support and exhaust pipe bracket from transmission. Attach suitable lifting sling to engine. Mark position of transmission crossmember in relation to chassis base panel, disconnect rubber mount and remove crossmember.

5) Disconnect speedometer cable from transmission. Disconnect propeller shaft and shaft plate from transmission, loosen clamping nut and slide shaft and plate to the rear. Loosen power steering pump bracket and push reservoir towards engine.

6) Remove front engine mount bolts and front limit stop. Raise engine slightly, tilt it at a 45° angle and lift out engine and transmission assembly. Separate engine from transmission. To install, reverse removal procedure.

### CYLINDER HEAD REMOVAL

**Removal** — 1) Drain cooling system. Disconnect all water hoses attached to cylinder head. Remove vent line, air cleaner and rocker cover.

2) Disconnect vacuum and fuel line from carburetor. Loosen fuel filter screws and move filter out of way. Disconnect exhaust pipe at manifold.

3) Disconnect spark plug wires from spark plugs and heat sensor from thermostat. Rotate engine until camshaft is in a position to have opened the least amount of valves as possible.

4) Remove top chain guide. Unscrew camshaft sprocket screw. Remove chain tensioner and camshaft sprocket.

5) Loosen and remove head bolts, working from outside toward inside of head. Remove four socket screws at front of head. Lift off head and gasket.

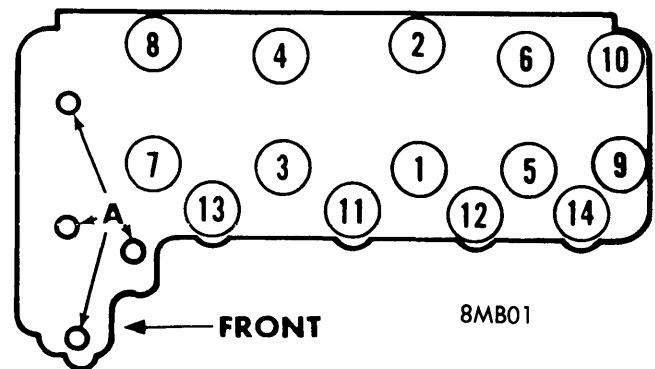

### CYLINDER HEAD TIGHTENING SEQUENCE

**Installation** — 1) Rotate engine until No. 1 piston is at TDC on compression stroke. Install head gasket and cylinder head. Torque head bolt in sequence shown in illustration to required specifications.

2) Install four socket head screws at front of cylinder head. Insert Woodruff key in camshaft. Position shim on camshaft to align with mark on first camshaft bearing support.

3) Install camshaft sprocket and chain placing tension on driving side of chain. Use care not to move either camshaft or crankshaft.

4) Check end play of camshaft. See *Camshaft Bearing Replacement*. Install upper chain guide. Using new seal, fill chain tensioner with oil and install in place.

5) Position rocker arm assembly, rotate camshaft until no load is on rocker arms while tightening. Adjust valve lifters with engine cold. See *Valve Clearance Adjustment*.

6) Reassemble remaining components in reverse order of removal. Operate engine until temperature reaches 176°F, then retighten cylinder head bolts and recheck valve lifter clearance. Operate vehicle for 180-600 miles before final torque on head bolts. Loosen each head bolt slightly before tightening bolt to final torque.

## 230 4 CYLINDER (Cont.)

VALVES							
Engine & Valve	Head Diam. In. (mm)	Face Angle	Seat Angle	Seat Width In. (mm)	Stem Diameter In. (mm)	Stem Clearance In. (mm)	Valve Lift In. (mm)
2307 cc Intake	1.846-1.854 (46.9-47.1)	45°	45°	.051-.079 (1.3-2.0)	.352-.353 (8.95-8.97)	.....	.....
Exhaust	.455-1.465 (36.95-37.25)	45°	45°	.059-.079 (1.5-2.0)	.430-.431 (10.93-10.95)	.....	.....

### VALVE ARRANGEMENT

E-I-I-E-E-I-I-E (front to rear).

### VALVE GUIDE SERVICING

1) Thoroughly clean carbon from guide bore and measure inside diameter. If measurement exceeds .3553" (9.03 mm) on intake guides or .4343" (11.03 mm) on exhaust guides, guide must be replaced.

2) Drive guides out through top of head with a suitable driver. Drive new guides into cylinder head from top until snap ring contacts top of head. Guide bores might require reaming to obtain correct fit with valve stem.

3) Valve guides require a .0004-.0012" (.01-.03 mm) press fit in cylinder head. If fit is too loose, two oversize valve guides are available. Size of oversize guides is determined by a color code. Standard guide outside diameter is .5523-.5531" (14.03-14.05 mm) for intake guides and .5917-.5925" (15.03-15.05 mm) for exhaust guides.

### Valve Guide Specifications

Application	In. (mm)
Intake Guide	
Red Code .....	.5594-.5602 (14.21-14.23)
White Code .....	.5673-.5681 (14.41-14.43)
Exhaust Guide	
Red Code .....	.5988-.5996 (15.21-15.23)
White Code .....	.6066-.6075 (15.41-15.43)

### VALVE STEM OIL SEALS

Valve seals are used on both intake and exhaust valves. Seal is teflon-type material utilizing lock ring mounted around seal to secure unit to valve guide. Valve spring must be removed to replace seal.

### VALVE SPRINGS

Engine	Free Length In. (mm)	PRESSURE Lbs. @ In. (kg @ mm)	
		Valve Closed	Valve Open
2307 cc	1.77 (44.9)	28.2-33.5@1.22 (12.8-15.2@31)	50.3-55.6@.827 (22.8-25.2@21)
		1.97 (50)	79.4@1.54 (36@39)

### VALVE SPRING REMOVAL

Compress valve spring with a suitable spring compressor. Remove valve keepers and release spring compressor. Remove upper spring seat, both valve springs and valve rotator. Check spring for wear or fatigue and replace as necessary. To install valve springs, reverse removal procedure.

### ROCKER ARM ASSEMBLY

1) Remove valve cover. Remove spring clamp from notch in top of rocker arm and push outward over ball cup of rocker arm. Rotate camshaft until there is no load on rocker arm being removed.

**CAUTION** — Rotate engine in correct direction of rotation by cranking collar bolt on crankshaft. Do not rotate by turning bolt on camshaft. If these procedures are not followed, drive chain tensioning rail could be distorted or damaged.

2) Insert a suitable spring compressor (112 589 08 61 00) between camshaft and valve spring and push valve spring down to relieve pressure from rocker arm. Lift rocker arm off of ball pin and remove.

3) To install rocker arm, reverse removal procedure. Check and, if necessary, adjust valve clearance.

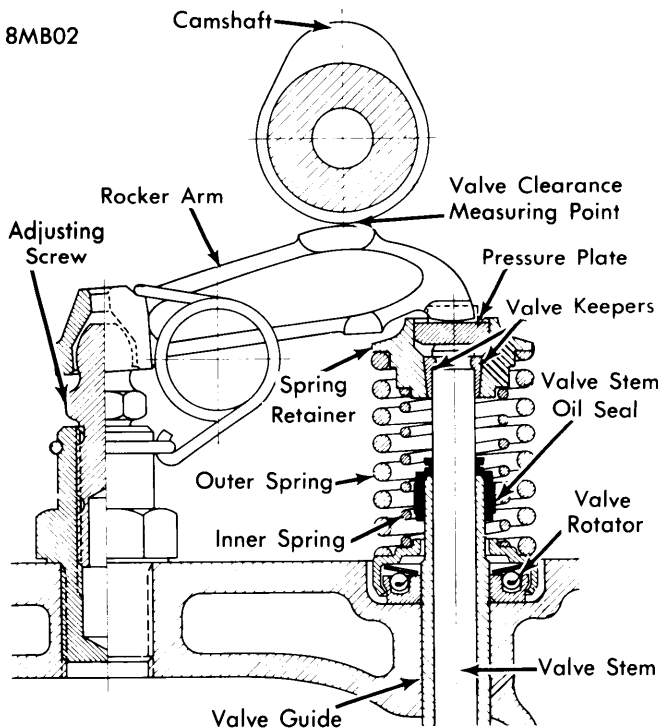

VALVE TRAIN COMPONENTS

## 230 4 CYLINDER (Cont.)

### MECHANICAL VALVE LIFTER ADJUSTMENT

1) Valve clearance can be checked or adjusted with engine either cold or warm. Clearance is measured between sliding surface of rocker arm and heel of camshaft. Remove breather line from valve cover and remove valve cover.

2) Rotate engine until camshaft lobe is pointing away from sliding surface of rocker arm to be checked. **CAUTION** — Rotate engine in correct direction of rotation by use of collar bolt on crankshaft. Do not try to turn engine using bolt on camshaft end as drive chain tensioning rail could be distorted or damaged by not following correct procedure.

3) Measure valve clearance. If clearance is too tight, turn rocker arm adjusting screw clockwise using suitable adjusting wrench (000 589 32 07 00 or equivalent) and a torque wrench. If clearance is excessive, turn adjusting screw counterclockwise.

4) A required torque of 14.5-28.8 ft. lbs. (2-4 mkg) is needed when screwing adjusting screw in or out of cylinder head. If torque is less, adjusting screw, base plate or both must be replaced.

5) If clearance is too small and adjusting screw cannot be screwed into cylinder head any further, a thinner pressure plate must be installed in valve spring retainer. Standard thickness of pressure plate is .177" (4.5 mm). Undersize plates are available .138" (3.5 mm) and .098" (2.5 mm) thick.

### Valve Clearance Specifications

Application	Clearance
Intake	
Cold .....	.004" (.10 mm)
Warm .....	.006" (.15 mm)
Exhaust	
Cold .....	.008" (.20 mm)
Warm .....	.010" (.25 mm)

PISTONS, PINS, RINGS						
Engine	PISTONS	PINS		RINGS		
	Clearance In. (mm)	Piston Fit In. (mm)	Rod Fit In. (mm)	Rings	End Gap In. (mm)	Side Clearance In. (mm)
2307 cc	.0008-.0011 (.02-.03)	.0000-.0001 (.0000-.0025)	.0004-.0009 (.0101-.0228)	No. 1	.012-.018 (.30-.45)	.0019-.0032 (.050-.082)
				No. 2	.012-.018 (.30-.45)	.0015-.0028 (.040-.072)
				No. 3	.010-.016 (.25-.40)	.0004-.0016 (.010-.042)

### OIL PAN REMOVAL

**Removal & Installation** — 1) Drain engine oil. Remove dipstick and guide tube. Take off cover plate from clutch housing. Unbolt oil pan.

2) Loosen steering shock absorber and drag link, turn both to one side. Unscrew drag link on intermediate steering and turn aside. Remove oil pan.

3) Clean all surfaces thoroughly. Install new gaskets. Position oil pan in place, tighten bolts, and reinstall all related parts in reverse of removal procedure.

### PISTON & ROD ASSEMBLY

**Removal** — 1) Remove cylinder head and oil pan. Unscrew connecting rod nuts. Tap rod bolts with a plastic mallet to loosen rod on crankshaft. Push piston and connecting rod assembly out top of cylinder block.

2) Remove piston circlips. Heat piston to 104-140°F and press out piston pins.

**Installation** — 1) Heat piston and reinstall piston pin and circlips. Piston and piston pin must be matched.

2) Install connecting rod and cap so cylinder numbers face left side of engine and arrow on piston crown faces forward.

**NOTE** — Piston must be installed facing proper direction or damage to the engine will occur.

3) Connecting rod bolts must be replaced if, after several tightenings, expansion has reached minimum diameter of

.2834" (7.2 mm). Normal diameter of connecting rod bolts is .3307" (8.4 mm). Drive out old bolts and insert new bolts using same spline face position.

**NOTE** — First tightening after new bolts are installed is 50 ft. lbs. (7 mkg). Subsequent tightenings are 36 ft. lbs. (5 mkg).

4) Rotate crankshaft until piston is at TDC. Measure distance between top of cylinder block and piston crown. Piston must not recess more than .024-.043" (.6-1.1 mm) below block surface.

### FITTING PISTONS

Measure piston and cylinder diameters to determine running clearance. Piston diameter is measured at 90° to piston pin bore near bottom of piston skirt. Install rings with marking "TOP", "F" or "GOE" up.

### Piston Specifications

Application	In. (mm)
Standard .....	3.6902-3.6910 (93.73-93.75)
1st Oversize .....	3.7059-3.7067 (94.13-94.15)
2nd Oversize .....	3.7216-3.7224 (94.53-94.55)

### PISTON PINS

**Removal & Installation** — Remove circlips, heat piston to 104-140°F and press out piston pin using suitable tool. Check pin for undue wear or fatigue, replace if necessary. Diameter of piston pin should be 1.0234-1.0236" (25.994-25.999 mm). Heat piston and install piston pin and circlips.

# Mercedes-Benz Engines

## 230 4 CYLINDER (Cont.)

CRANKSHAFT MAIN & CONNECTING ROD BEARINGS							
Engine	MAIN BEARINGS			CONNECTING ROD BEARINGS			
	Journal Diam. In. (mm)	Clearance In. (mm)	Thrust Bearing	Crankshaft End Play In. (mm)	Journal Diam. In. (mm)	Clearance In. (mm)	Side Play In. (mm)
2307 cc	2.7541-2.7545 (69.95-69.96)	.0018-.0026 (.045-.066)	Center	.004-.009 (.10-.22)	2.045-2.046 (51.94-51.97)	.0014-.0022 (.035-.055)	.0043-.0091 (.10-.23)

### MAIN & CONNECTING ROD BEARINGS

Measure main bearing and connecting rod journals for out-of-round and taper. Out-of-round must not exceed .0002-.0004" (.005-.010 mm) and taper .0004-.0006" (.010-.015 mm). Select proper undersize and grind crankshaft to following diameters:

#### Crankshaft Journal Diameters

Application	Main In. (mm)	Connecting Rod In. (mm)
Standard.....	2.7541-2.7545 (69.95-69.96)	2.0454-2.0458 (51.95-51.96)
1st Undersize.....	2.7442-2.7446 (69.70-69.71)	2.0356-2.0360 (51.70-51.71)
2nd Undersize.....	2.7344-2.7348 (69.45-69.46)	2.0257-2.0261 (51.45-51.46)
3rd Undersize.....	2.7246-2.7249 (69.20-69.21)	2.0159-2.0163 (51.20-51.21)
4th Undersize.....	2.7147-2.7151 (68.95-68.96)	2.0060-2.0064 (50.95-50.96)

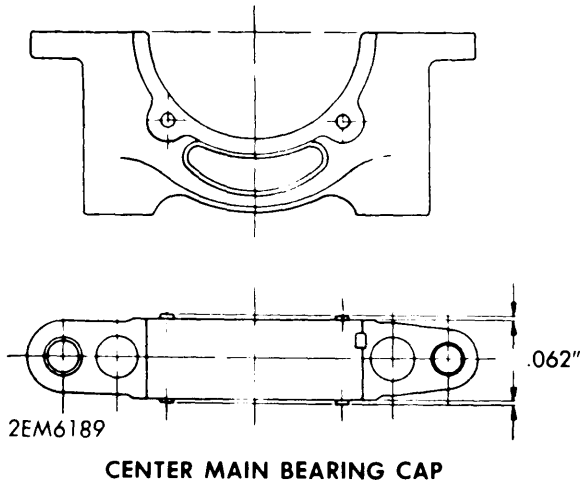

### THRUST BEARING ALIGNMENT

Center main bearing cap has pin-located thrust washers to adjust crankshaft end play. Measure end play and install thrust washers giving proper end play. Measure pin protrusion from main bearing cap to see that it does not exceed .062" (1.6 mm), as illustrated. Standard and oversize thrust washers are available in the following sizes:

### Thrust Washer Specifications

Application	In. (mm)
Standard.....	.078 (1.98)
1st Oversize.....	.080 (2.03)
2nd Oversize.....	.082 (2.08)
3rd Oversize.....	.084 (2.13)
4th Oversize.....	.086 (2.18)
5th Oversize.....	.088 (2.23)
6th Oversize.....	.090 (2.28)
7th Oversize.....	.092 (2.33)

### REAR MAIN BEARING OIL SEAL

- 1) With oil pan and crankshaft removed, insert fabric oil seal in crankcase groove behind rear main bearing. Cut seal so that seal protrudes slightly above parting face.
- 2) Install other seal half in oil pan groove, coat lubricant on seal halves. Reinstall crankshaft and oil pan. Rotate crankshaft to check tightness of seal, if too tight, remove oil pan and crankshaft, tamp down high spots using suitable tool to roll down material. Reinstall all related parts.

### FRONT OIL SEAL

- Removal** - 1) Remove attaching bolt and crankshaft pulley. Attach a suitable puller and remove counterweight. Remove oil pan.
- 2) Press out seal ring and remove spacer from crankshaft.

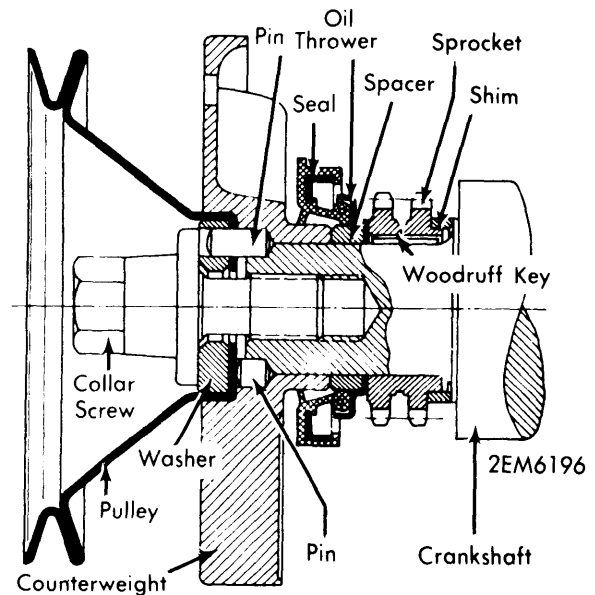

**CRANKSHAFT FRONT OIL SEAL**

## 230 4 CYLINDER (Cont.)

**Installation** — 1) Fill new seal between sealing lips with hot bearing grease and coat outer diameter with sealing compound.

2) Slide oil thrower ring and seal onto crankshaft. Press seal in until it touches face of crankcase. Slide spacer ring onto crankshaft.

3) Replace oil pan. Install remaining components in reverse of removal procedures.

### TIMING CHAIN REPLACEMENT

1) Remove rocker cover and disconnect spark plug wires at spark plugs. Remove all four spark plugs to allow engine to turn over freely.

*NOTE* — Removal of rocker arm brackets is not imperative, but is recommended in order to avoid damage to valves or pistons, if, while turning engine, chain jumps over camshaft sprocket.

2) Grind off pins on a link of old chain and remove link. Using a master link, connect new chain to old chain on driving side of old chain.

*NOTE* — Install master link facing camshaft side of chain with spring lock closed end facing direction of rotation (see illustration).

3) Slowly turn engine in direction of rotation, feeding new chain in and old chain out uniformly. After chain threading is complete, join ends of new chain with master link and make sure spring lock closed end is facing direction of rotation. Check that valve timing is correct. See *Valve Timing*. Reverse removal procedures for remaining components.

### VALVE TIMING

1) Rotate No. 1 piston to TDC of compression stroke. Align camshaft timing mark with mark on No. 1 camshaft bearing support bracket (see illustration). Install camshaft sprocket.

2) If correct valve timing is not achieved when camshaft sprocket is installed, offset Woodruff keys are available to make timing corrections, see following table:

### Offset Woodruff Keys

Offset	Crankshaft Correction
.0275" (.7 mm)	4°
.0354" (.9 mm)	6 1/2°
.0433" (1.1 mm)	8°
.0511" (1.3 mm)	10°

VALVE TIMING				
Engine	INTAKE		EXHAUST	
	Open (BTDC)	Close (ALDC)	Open (BLDC)	Close (ATDC)
2307 cc	14°	20°	22°	12°

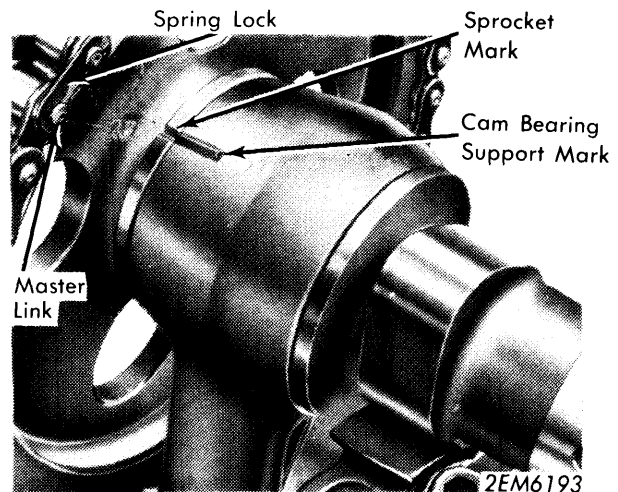

**CAMSHAFT TIMING MARKS & TIMING CHAIN MASTER LINK**

## ENGINE OILING

**Crankcase Capacity** — 5.8 qts. with filter.

**Oil Filter** — Full-flow, clean main element 3,000 miles. Replace by-pass element 3,000 miles.

**Normal Oil Pressure** — Min. 42 psi@3000 RPM.

**Pressure Regulator Valve** — Non-adjustable.

### ENGINE OILING SYSTEM

Engine lubrication is provided by a gear type oil pump, which force feeds oil through an oil filter to oil gallery. From oil gallery, oil flows to main and connecting rod bearings. Pistons, wrist pins and connecting rod bushings are splash lubricated. A vertical oil passage from oil gallery has a transverse passage which supplies oil to intermediate sprocket shaft and bearings. Another oil passage supplies oil to oil pump drive shaft and helical gear. Vertical passage also supplies oil to No. 1 camshaft bearing. An external oil tube attached to No. 1 camshaft bearing support lubricates other camshaft bearings and rocker arms.

### OIL PUMP

**Removal** — Remove oil pan. Remove two attaching screws and lift out pump.

**Disassembly** — 1) Remove oil strainer. Unscrew lower pump body, and remove pump gears and shafts. Measure clearances between gear-to-body and gear-to-cover (see specifications).

2) If cast-in bushings in housing are worn, replace complete housing. Worn gears are replaced as an assembly. Assemble upper and lower housing without a gasket. Install strainer with a new gasket. Check that pump turns freely.

**Installation** — 1) Align drive shaft follower with helical gear and follower faces with respect to one another.

2) Insert oil pump with bracket and tighten mounting screws. Install oil pan.

### Oil Pump Specifications

Application	In. (mm)
Gear-to-Body	.0009-.0022 (.02-.06)
Gear-to-Cover	.0018-.0029 (.05-.07)
Backlash	.0019-.0059 (.05-.15)

# Mercedes-Benz Engines

## MERCEDES-BENZ 230 4 CYLINDER (Cont.)

### ENGINE COOLING

**Cooling System Capacity** — 10.6 qts. with heater.

**Thermostat** — Wax Pellet Type, opens at 170-179°F (77-81°C).

### WATER PUMP

**Removal** — 1) Drain cooling system below level of pump. Loosen hose clamps on top radiator hose. Remove radiator mounting bolts and push radiator forward.

2) Remove fan from drive pulley. Loosen nuts and adjusters on generator enough so fan belt may be removed. Unscrew and remove venting line between pump and cylinder head.

3) Water pump is a maintenance-free type. When installing pump, check hub-to-flange and impeller-to-flange distance, (see illustration).

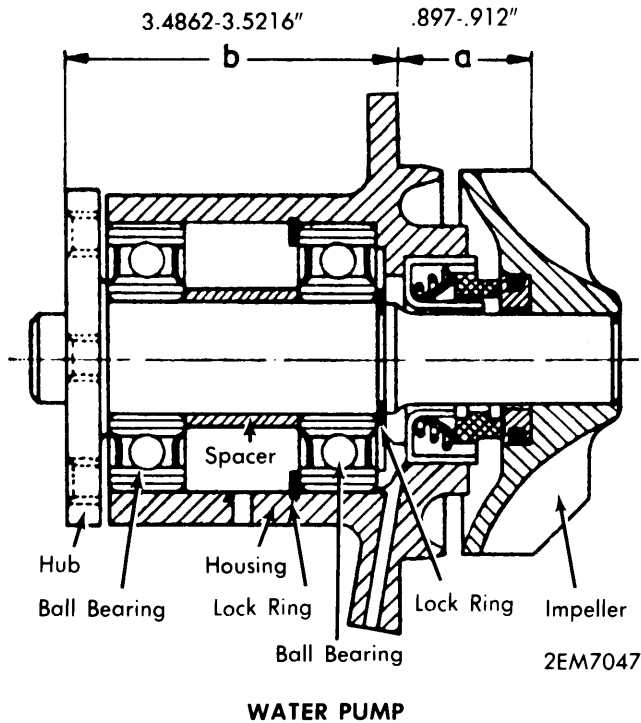

### TIGHTENING SPECIFICATIONS

Application	Ft. Lbs. (mkg)
Cylinder Head Bolts .....	⓪ 65 (8.9)
Rocker Arm Mounting Bolts .....	58 (8.0)
Rocker Arm Bearing Bracket Bolts .....	27 (3.7)
Connecting Rod Bolts .....	43 (5.9)
Main Bearing Cap Bolts .....	58 (8.0)
Crankshaft Bolt (Front) .....	130 (17.9)
Pulley & Vibration Damper Bolts .....	25 (3.5)
Oil Pan Bolts .....	6 (.8)
Oil Filter Bolt .....	25 (3.5)

⓪ — Tighten in four stages; 29 ft. lbs. (4.0 mkg), 43 ft. lbs. (5.9 mkg), and 65 ft. lbs. (8.9 mkg). After running engine, loosen each bolt and retighten to 65 ft. lbs. (8.9 mkg.)