

XJ12 & "E" TYPE SERIES 3 V12

| GENERAL SPECIFICATIONS | | | | | | | | | | |
|------------------------|----------|------|------------|-----------|--------------------------|--------------|-------|----|--------|----|
| Year | Displ. | | Carburetor | HP at RPM | Torque (Ft. Lbs. at RPM) | Compr. Ratio | Bore | | Stroke | |
| | cu. ins. | cc | | | | | in. | mm | in. | mm |
| 1974 | 326 | 5343 | 4x1 Bbl. | | | 9.0:1 ① | 3.543 | 90 | 2.756 | 70 |

① — See Engine Identification.

ENGINE IDENTIFICATION

Engine number is stamped on cylinder block at rear of engine, between cylinder heads. Two compression ratios are used in these engines and are identified by the suffix letter as follows:

| Suffix Letter | Comp. Ratio |
|---------------|-------------|
| S | 9.0:1 |
| L | 7.8:1 |

ENGINE REMOVAL

NOTE — It is necessary to remove entire power unit (engine and transmission assembly) as an assembly. Engine and transmission may then be separated.

"E" Type Series 3 — 1) Remove hood, disconnect and remove battery. Drain cooling system, remove air cleaners and disconnect ground strap from bell housing.

2) Disconnect wires from oil pressure sending unit and disconnect radiator hoses. Remove radiator attaching nuts. Disconnect oil cooler hoses from radiator on cars equipped with automatic transmissions.

3) Disconnect top water pipes from hoses at radiator and engine end. Disconnect hose from underside of radiator expansion tank, disconnect expansion tank hose from radiator. Disconnect bottom hose.

4) If equipped with air conditioning system, remove nuts and bolts holding compressor to mounting bracket and remove bolts holding condenser to radiator assembly. Place compressor and condenser on floor to right of sub-frame. Make sure that hoses are not damaged by twisting.

NOTE — No attempt should be made to disconnect any part of air conditioning system. Refrigerant gas in system is under high pressure and serious injury to eyes can result if gas comes in contact with eyes.

5) Remove nuts and bolts holding radiator braces to sub-frame and lift out radiator complete with fans and cowls.

6) Disconnect hoses from intake housings on engine. Remove nuts and bolts holding front crossmember to sub-frame, disconnect ground strap and remove crossmember complete with expansion tank.

7) Disconnect heater hoses and fuel lines from crossover pipe. Disconnect breather pipe from left rear intake manifold. Loosen pinch bolts and release clips holding choke cables. Release clips holding choke cables to crossover pipe.

8) Disconnect throttle cable from pedestal and disconnect clutch pipe at firewall bracket. Plug or tape all connections to prevent entry of dirt.

9) Remove power steering pump mounting bolts and swing pump clear of engine. Disconnect wires from alternator, noting and marking wires for proper replacement. On cars with automatic transmission, disconnect wires from kickdown switch.

10) Disconnect carbon canister pipe from balance pipe and disconnect balance pipe from hose. Disconnect rubber hoses from rear of air pump. Remove air pump mounting bolts and remove air pump from mounting bracket.

11) From inside car, remove transmission console and fold carpet away from lower edge of transmission cover. Remove two bolts, one on each side of transmission cover. This will release rear crossmember under car.

12) Remove nuts holding front pipes to exhaust manifolds and release rubber rings holding muffler clamp to floor pan. Lower system slightly and pull forward to disengage from rear mounting bracket.

13) Disconnect speedometer cable from transmission and disconnect back-up light. Remove two bolts holding front lower crossmember and disengage crossmember from mounting bracket.

14) Remove screws holding rear heat shield to floor pan and remove heat shield. Remove screws and remove front heat shields. Disconnect starter electrical connections. Place jack under transmission extension housing.

15) Attach suitable engine hoist to engine lifting eyes. Remove engine mount bracket support plate-to-floor pan bolts, and remove center nut from rear engine mount. Remove washer, support plate, spring seat, spacers and washers.

NOTE — Chains of engine hoist must be of sufficient length to ensure that distance between lifting eyes and hook of hoist is 34.5" (87.6 cm) from front eyes to hook and 41" (104.1 cm) from rear eyes to hook.

16) Lower rear of engine slightly and remove nuts and bolts holding propeller shaft to transmission output flange. On cars with automatic transmission, disconnect gear linkage.

17) Remove nuts and bolts holding engine mounting to brackets. Lift engine slightly and remove through front of sub-frame.

NOTE — Care should be taken to make sure engine and transmission does not bind or get caught on anything. Particular attention should be given to shift levers and pipe connections.

XJ 12 — 1) Remove hood and battery. Drain engine and cooling system.

NOTE — Only qualified air conditioning personnel should loosen or remove air conditioning hoses or fittings to prevent personal injury. All hoses or fittings which are removed should be immediately sealed with clean dry plugs.

2) On air conditioned models, discharge air conditioning system. Disconnect suction and pressure hoses. Remove pressure and suction unions from rear of compressor and plug openings. Tie hoses back away from engine.

3) Remove fender well straps and air cleaners. Disconnect oil pump-to-cooler lines and remove radiator complete with oil cooler.

XJ12 & "E" TYPE SERIES 3 V12 (Cont.)

4) On air conditioned models, remove compressor delivery hose from vehicle. Tie condenser/evaporator hose back away from engine.

5) Disconnect coolant hoses to remote header tank at engine. Remove nut and lock washer attaching engine mount to engine bracket. Remove oil from power steering reservoir. Disconnect lines from power steering pump.

6) Disconnect connectors from alternator and separate engine harness connector. Remove hose between servo unit and vacuum reservoir. Disconnect fuel feed line at cross-over pipe stub and return line to non-return valve. Tie lines back against body.

7) Disconnect operating line from heater vacuum reservoir non-return valve at manifold stub and heater water valve at valve inlet. Disconnect heater return line from water rail at firewall union. Remove coil and ballast resistor assembly.

8) Disconnect throttle cross rod at left-hand bellcrank and swing forward to rest on engine. Disconnect choke cables at carburetors, pull cross-over cable from guides in air rail clamps. Remove connectors from kickdown switch.

9) Disconnect throttle cables from throttle pedestal plate and platform. Pull carbon canister hoses from carburetor balance pipe and carburetor float chamber breather pipe. Remove starter cable from firewall terminal.

10) Install suitable engine support tool (MS.53A) into drip channel directly above rear lifting eyes and tighten supporting screws. Disconnect both exhaust pipes at manifolds. Remove front exhaust pipe which is not trapped by steering pinion housing. Lower trapped front pipe and move rear end of pipe toward center line of vehicle. Slide pipe towards front of vehicle and draw flanges down past steering housing.

11) Remove attaching hardware from heat shields. Remove four screws, washers and spacers from engine mounting plate. Place a jack and suitably formed block of wood beneath mounting plate and remove nut attaching rear engine mount.

12) Lower jack and remove mounting plate. Disconnect propeller shaft and speedometer cable. Remove pinch bolt attaching transmission outer selector cable and disconnect inner cable from selector lever at transmission by removing nut and lock washer.

13) Remove ground strap from frame member. Place a jack beneath front suspension crossmember and remove engine support tool. Attach suitable lifting sling to engine eyes.

NOTE — Chains of engine hoist must be of sufficient length to ensure that distance between lifting eyes and hook of hoist is 35.5" (87.6 cm) from front eyes to hook and 41" (104.1 cm) from rear eyes to hook.

14) Carefully lift engine with hoist, simultaneously raising jack to keep engine level. Lift only 2-3" (50-70 mm).

CAUTION — Throughout lift, rear of engine must be kept as high as possible until oil pan is clear of steering housing.

15) Lift engine level, while observing forward corner of oil pan and steering housing. Apply side pressure to engine until it has been lifted clear of steering assembly and lines. Pull engine from subframe, allowing angle of tilt to increase until drive flange is clear of firewall. Lift engine to clear bumper.

INTAKE MANIFOLD REMOVAL

NOTE — On "E" type series 3 vehicles, engine has four separate intake manifolds. The following procedures may be used for any of these manifolds. Carburetors do not mount

directly to intake manifolds. An intake housing is bolted in between intake manifold and carburetor.

"E" Type Series 3 — 1) Disconnect battery ground cable, and loosen heat shield retaining bolts and remove heat shield. If working on a rear manifold, disconnect carburetor linkage. If working on a front manifold, disconnect balance pipe from carburetor.

2) Remove air rail. Release clip which holds carburetor balance pipe. If working on a front manifold, release clip holding manifold pipe to carburetor.

3) Remove manifold-to-cylinder head nuts and washers, remove manifold-to-intake housing bolts and washers. Note position of choke cable clip and remove manifold. Remove and discard gaskets and plug exposed intake ports to prevent entry of dirt into engine. To install, reverse removal procedure using new gaskets.

NOTE — On XJ 12 vehicles, intake manifolds and intake housings are similar to those used on "E" type series 3 vehicles. On XJ 12 vehicles, intake manifolds, intake housings and carburetors will be removed as left and right assemblies.

XJ 12 — 1) Remove air cleaner and drain cooling system. Remove fender stay. On air conditioned vehicles, remove clamps attaching hoses to condenser.

2) Remove clamps attaching fuel line at inlet "T" piece hose. On right-hand manifolds, remove clamps on brake vacuum hose at manifold valve and servo. Pull off carburetor balance pipe branch. Disengage balance pipe from clamp on manifold and crankcase breather pipe (left-hand) from balance pipe. Lay balance pipe across engine.

3) Remove float chamber balance pipe from clamp. Pull bypass valve pipes from carburetors. Pull vacuum pipe from rear of front manifold. Release throttle edge by tapping pipe from clamp (left-hand).

4) Disconnect manifold balance pipe and choke cable. Release throttle cross rod from bellcrank, remove set screws attaching throttle cable guide bracket. Disconnect radiator top hose at both ends and intake housing bleed pipe.

5) On left-hand manifolds, disconnect automatic transmission vacuum reference hose and heater system vacuum hose from rear of intake manifold. Remove heater water control valve from rear of water gallery.

6) Disconnect engine cross pipe from thermostat housing. Remove thermostat housing and lifting eye. Remove manifold cylinder head branch pipe and lifting eye. On left-hand manifold, remove dipstick tube clamp from forward carburetor.

7) Remove air rail clamp screws from intake manifold bosses. On right-hand manifolds, pull vacuum pipes from thermostatic vacuum switch and remove coil and ballast resistor. Remove intake manifolds from engine. To install, reverse removal procedures.

INTAKE HOUSING REMOVAL

NOTE — On "E" type series 3 vehicles, engine has two separate intake housings; one for right side and one for left side. Carburetors mount to housings; two carburetors on right and two on left. The following procedures may be used for either of these housings.

"E" Type Series 3 — 1) Disconnect battery ground cable, drain cooling system, remove air cleaner and heat shields. If working on right side housing, disconnect carbon canister pipe from balance pipe.

XJ12 & "E" TYPE SERIES 3 V12 (Cont.)

2) Disconnect balance pipe from carburetor, and remove clip holding fuel line to "T" fitting. If working on right side housing, proceed with step 3). If working on left side housing, proceed with step 4).

3) Disconnect expansion tank hose from front of intake housing, disconnect carburetor linkage. Release clip holding choke cable to bracket and disconnect choke cable from front carburetor.

4) Release clip holding choke cable to bracket and disconnect choke cable from rear carburetor. Disconnect carburetor linkage. Remove nut and bolt holding dipstick tube clip. Disconnect expansion tank hose from front of intake housing and disconnect vacuum pipe from bottom of rear carburetor flange.

5) Remove bolts and washers holding intake manifold to intake housing. Disconnect pipes joining water rails to intake housing and remove housing complete with carburetors. To install, reverse removal procedures and use new gaskets.

CYLINDER HEAD REMOVAL

NOTE — The following procedure may be used for removal of either right or left cylinder head.

1) Disconnect battery and drain cooling system. Remove right camshaft cover (necessary to remove right hand camshaft cover to remove either right or left cylinder head). Remove rubber grommet from timing cover.

2) Rotate engine, using crankshaft damper nut until valve timing gauge (C.3993) can be fitted in slot in camshaft front flange. Insert blade of suitable screwdriver (JD.42-2) through hole and release locking catch on timing chain tensioner. Using suitable tool (JD.42 and support plate JD.42-1 or JD.44) retract timing chain tensioner.

3) If left cylinder head is to be removed, remove left camshaft cover. Disconnect camshaft sprocket from camshaft and attach a suitable retaining tool (Special Tool JD.40).

4) Remove heat shield from exhaust manifold and solenoid heat shield (right-hand head). Loosen screw clamp attaching heater return pipe-to-hose and ease cross pipe forward. Remove clamps attaching manifold coolant bleed pipe to front of cylinder head.

5) Remove camshaft oil feed banjo nut. Remove three nuts holding front of cylinder head to timing cover. Progressively loosen cylinder head nuts working from center outward. Remove cylinder head and place on wood blocks to prevent damage to valves. Discard old gasket.

NOTE — Do not rotate engine until suitable cylinder liner retaining tools (Special Tool JD.41) have been attached to cylinder head studs.

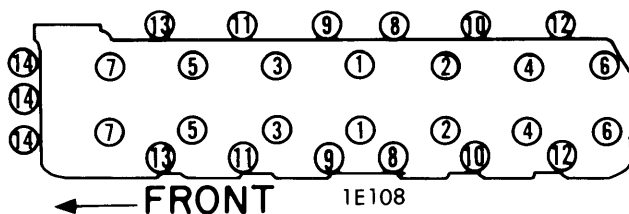

V12 CYLINDER HEAD TIGHTENING SEQUENCE

CYLINDER HEAD INSTALLATION

1) Attach suitable dial indicator to a cylinder head stud and rotate engine to set No. 1 piston on right bank at TDC. Turn camshaft until valve timing gauge (Special Tool C.3993) can be attached to slot in camshaft front flange. Repeat for camshaft on left cylinder head. Remove cylinder liner retaining tool.

NOTE — Do not rotate engine until cylinder head(s) are installed.

2) Install gasket making sure side marked "TOP" is up. Do not use jointing compound or grease. Install right cylinder head and nuts. Tighten nuts to specifications in order shown in illustration.

3) Tighten cylinder head-to-timing cover nuts to specifications. If camshaft and sprocket holes are not in alignment, remove circlip which holds camshaft coupling to sprocket and disengage coupling from splines.

4) Rotate coupling until access to retaining bolt holes can be obtained. Remove sprocket retaining tool (JD.40) and bolt coupling to camshaft.

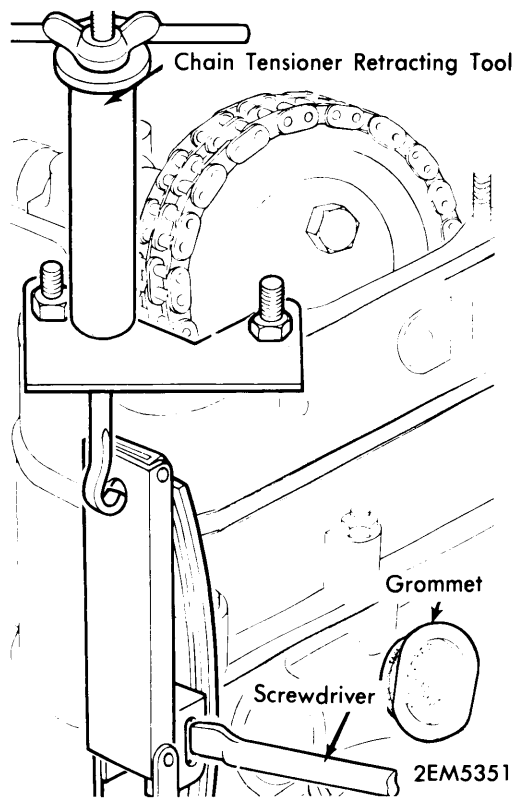

TENSIONER RETRACTING TOOL

XJ12 & "E" TYPE SERIES 3 V12 (Cont.)

5) Engage sprocket with coupling, then replace circlip and remove valve timing gauge (C.3993). Repeat procedures as outlined in steps 2) through 6) for left cylinder head.

6) Rotate engine until remaining camshaft sprocket retaining bolts can be installed; secure bolts with tab washers. Remove timing chain tensioner retracting tool (Special Tool JD.42 and Support Plate JD.42-1).

7) Insert suitable screwdriver (Special Tool JD.42-2) through hole in timing cover and trip locking catch. Reinstall rubber grommet.

8) Install exhaust pipes, camshaft covers, refill cooling system and reconnect battery.

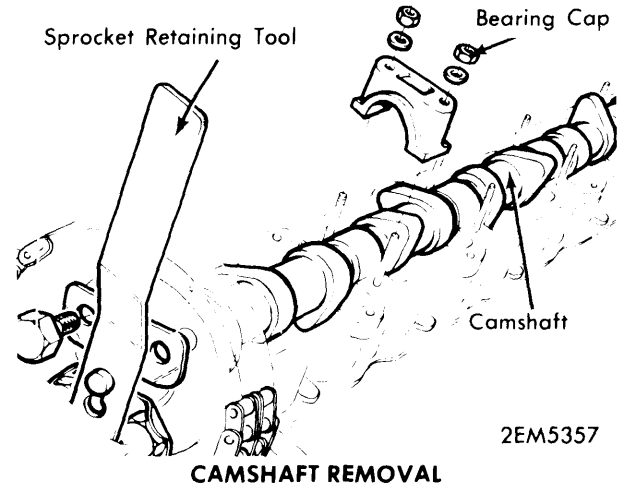

| VALVES | | | | | | | |
|----------------|------------------------------|------------|------------|---------------------|------------------------------|--------------------------|---------------------|
| Engine & Valve | Head Diam. In. (mm) | Face Angle | Seat Angle | Seat Width In. (mm) | Stem Diameter In. (mm) | Stem Clearance In. (mm) | Valve Lift In. (mm) |
| V12 Intake | 1.623-1.627 (41.22-41.32) | 45° | 44.5° | | .3092-.3093 (7.854-7.866) | .0020-.0023 (.05-.06) | .375 (9.5) |
| Exhaust | 1.358-1.362 (34.50-34.60) | 45° | 44.5° | | .3092-.3093 (7.854-7.866) | .0020-.0023 (.05-.06) | .375 (9.5) |

VALVE ARRANGMENT

E-I-E-I-E-I-E-I-E-I-E-I-E (both banks, front to rear).

VALVE GUIDE SERVICING

1) With valves and valve springs removed, check clearance between valve guide and stem. Clearance should be to specification.

2) To replace guides, immerse head in boiling water for 30 minutes. Using piloted drift, drive guide out of head from combustion chamber side. Coat new guide with graphite grease and attach circlip.

3) Heat cylinder head once again and drive guide in from top until circlip is seated in groove.

Replacement Guides

| Application | Marking | Size In. (mm) |
|--------------|-----------|----------------------------|
| 1st Oversize | 2 Grooves | .506-.507 (12.85-12.88) |
| 2nd Oversize | 3 Grooves | .511-.512 (12.98-13.00) |

4) When new guides are installed, always use next size larger than old guide. Ream guides to obtain proper valve stem clearance.

VALVE STEM OIL SEALS

Install valves and place cylinder head on wooden blocks. Install valve spring seats, intake valve oil seals, springs and collars. Compress springs using suitable tool (Special Tool J.6118B and Adaptor J.6118C-2) and install keepers.

NOTE - Oil seals used on intake valves only.

VALVE TAPPET CLEARANCE ADJUSTMENT

1) With intake manifolds and camshaft covers removed, check clearance between each tappet and heel of each cam. Record clearance for each and then subtract appropriate valve clearance from clearances obtained. Select suitable adjusting pads which equal this new measurement. Corrected clearance should be .012-.014" (cold).

| VALVE SPRINGS | | | |
|---------------|----------------------|-------------------------------|------------|
| Engine | Free Length In. (mm) | PRESSURE Lbs. @ In. (kg @ mm) | |
| | | Valve Closed | Valve Open |
| V12 Inner | 1.734 (44) | | |
| Outer | 2.103 (53.4) | | |

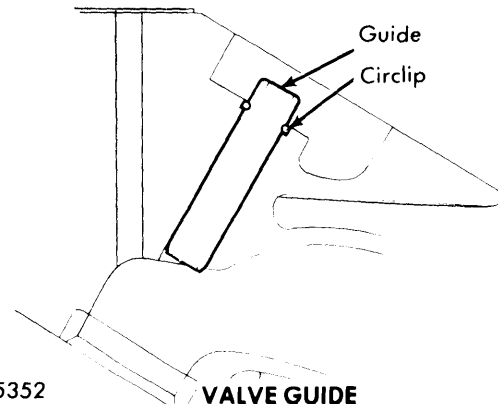

XJ12 & "E" TYPE SERIES 3 V12 (Cont.)

2) To install new adjusting pads, proceed as follows to remove camshaft and tappets: Bend back locking tabs and remove two camshaft sprocket retaining bolts. Rotate engine until access to remaining bolts is obtained. Bend back locking tabs, mark position of camshaft to sprocket, and remove bolts.

3) Using suitable tool (Jaguar Sprocket Retaining Tool JD.40), hold sprocket in place. Lift camshaft out of tappet block. Remove tappets and install adjusting pads.

NOTE — Do not rotate engine with camshaft disconnected.

4) Reinstall tappets, camshaft, bearing caps, washers and nuts. Tighten bearing cap nuts evenly to torque of 9 ft. lbs. Recheck clearance, reassemble, replace camshaft cover and manifolds.

NOTE — Adjusting pads are available in .001" (.03 mm) increment sizes from .085-.110" (2.16-2.79 mm). Pads have a letter stamped on surface which indicates size: "A" through "Z" respectively.

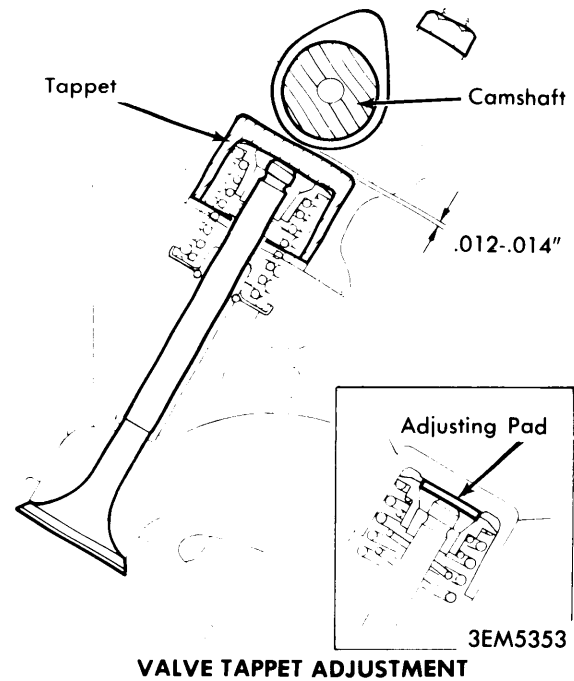

| PISTONS, PINS, RINGS | | | | | | |
|----------------------|--------------------------|------------------------|----------------------------|-------|-------------------------|----------------------------|
| Engine | PISTONS | PINS | | RINGS | | |
| | Clearance In. (mm) | Piston Fit In. (mm) | Rod Fit In. (mm) | Rings | End Gap In. (mm) | Side Clearance In. (mm) |
| V12 | .0012-.0017 (.03-.04) | Push Fit | .0000-.0002 (.000-.005) | 1 | .014-.020 (.36-.51) | .0029 (.07) |
| | | | | 2 | .010-.015 (.25-.38) | .0034 (.09) |
| | | | | Oil | .015-.045 (.38-1.14) | .0055-.0065 (.14-.17) |

OIL PAN REMOVAL

1) Drain engine oil and cooling system. Disconnect water hoses and heater hoses. Remove bolts holding front crossmember to mounting brackets and remove crossmember.

2) On "E" type series 3 vehicles, fold carpet away from both sides of transmission cover inside of vehicle. Remove rear crossmember bolts; one from each side of transmission cover. Remove rear crossmember.

3) Remove oil pan bolts and serrated washers. Lower oil pan. Remove and discard "O" ring from oil delivery elbow. To install, reverse removal procedure and use new "O" ring and oil pan gasket.

PISTON & ROD REMOVAL & INSTALLATION

1) With cylinder head and oil pan removed, remove crankcase baffle plate. Remove nuts, bearing cap and bearing. Push connecting rod up cylinder bore, remove piston together with connecting rod.

2) Coat all parts with engine oil and make sure that piston ring gaps are evenly spaced around circumference of piston. Place piston into bore with word "FRONT" facing forward and chamber on rod big-end facing crank pin radius. Push piston and rod assembly down into bore, locate bearings, install bearing caps and nuts and tighten to specifications.

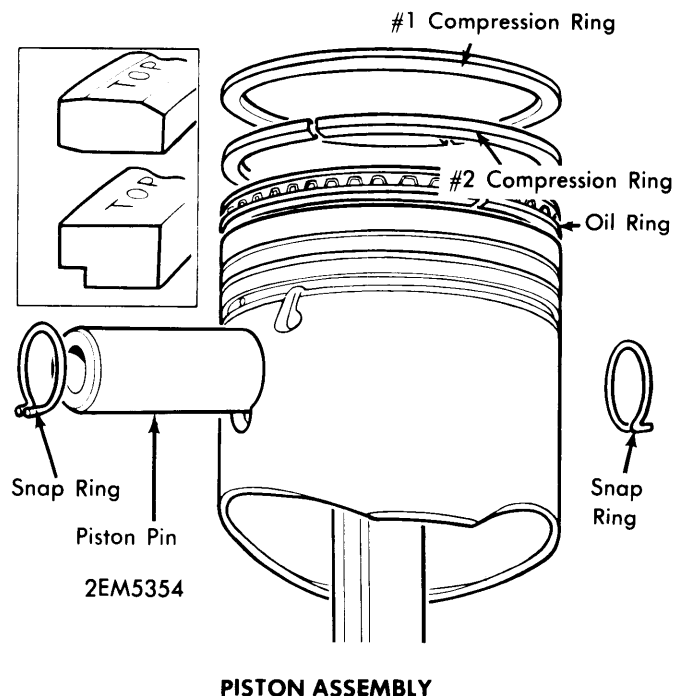

XJ12 & "E" TYPE SERIES 3 V12 (Cont.)

PISTON PIN REPLACEMENT

NOTE — *Pistons are supplied complete with pin. As pins and pistons are matched assemblies, it is not permissible to interchange component parts.*

- 1) Remove circlips from ends of piston pin bore. Immerse piston, pin, and connecting rod in hot oil (230°F). Remove from oil, push pin out.
- 2) To install pin, place pin in piston and align connecting rod with pin and push pin into place. Use new circlips.

FITTING PISTONS

No oversize pistons are available. Wet liner type cylinders. If liner or piston is damaged or worn to the extent that new liners or pistons are needed, replacement must be of standard size.

CYLINDER LINER REPLACEMENT

NOTE — *If liners are to be replaced after removal, they should be marked and reinstalled in their original bore.*

- 1) With crankshaft and pistons removed, remove cylinder liner retaining tools (Special Tools JD.41). Position a suitable mandrel between cylinder liner and arbor press.
- 2) Press out cylinder liners from below. To install, smear liners with Hylomar and slip liners into cylinder block. Remove excessive sealant. Make sure liners are correctly seated and install retaining tools.

MAIN BEARING SERVICE

- 1) With piston and rod assembly removed, remove bolts and locking plate holding flywheel (manual transmission) or drive plate (automatic transmission) to crankshaft.

- 2) Remove flywheel or drive plate. Remove nut and bolt holding oil suction pipe clamp to bracket and remove suction pipe. Remove small nuts holding main bearing caps. Start from center bearing.

- 3) Remove pillar nuts and large nuts holding main bearing caps. Start from center. Remove bearing caps and bearing. Slide rear main bearing casting out of cylinder block. Remove and discard seals. Lift crankshaft out of cylinder block, remove upper half of main bearings.

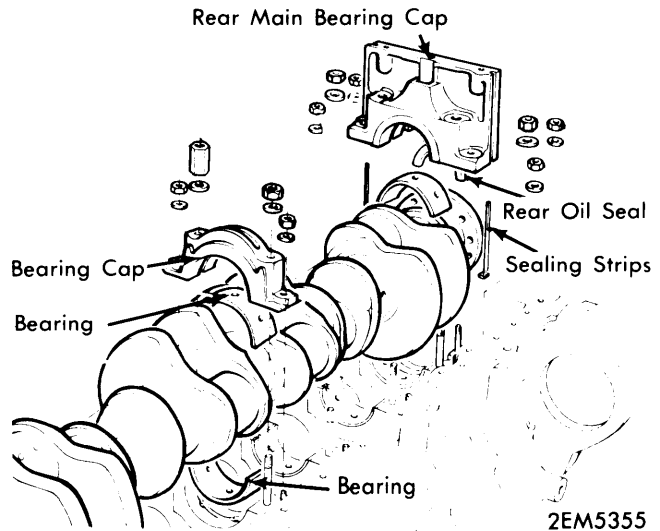

2EM5355

MAIN BEARINGS & REAR OIL SEAL

| CRANKSHAFT MAIN & CONNECTING ROD BEARINGS | | | | | | | |
|---|----------------------------------|-------------------------|-------------------|------------------------------------|--------------------------------|-------------------------|------------------------|
| Engine | MAIN BEARINGS | | | | CONNECTING ROD BEARINGS | | |
| | Journal Diam. In. (mm) | Clearance In. (mm) | Thrust Bearing | Crankshaft End Play In. (mm) | Journal Diam. In. (mm) | Clearance In. (mm) | Side Play In. (mm) |
| V12 | 3.0007-3.0012 (76.218-76.231) | .0015-.003 (.04-.07) | Center | .004-.006 (.10-.15) | 2.2994-2.3000 (58.40-58.42) | .0015-.003 (.04-.07) | .007-.013 (.17-.33) |

REAR MAIN BEARING OIL SEAL SERVICE

- 1) With crankshaft out of cylinder block and rear main bearing casting removed, install new sealing strips in grooves of rear main bearing casting. Install new rear oil seal. Install bearing casting on cylinder block and tighten nuts. Seat rear oil seal using suitable tool (Special Tool JD.17B & Adaptor JD.17B-1). Remove rear main bearing casting.

- 2) Coat upper main bearings with oil and install in cylinder block. Smear rear oil seal with Dag Colloidal Graphite. Oil upper main bearings and install in cylinder block, position crankshaft, install bearings in caps and install caps. Tighten to specifications.

NOTE — *Bearings are available in only standard size. Due to extremely hard surface of crankshaft journals, it is not possible to grind crankshafts satisfactory. Crankshafts are available on exchange basis and are supplied complete with matching bearings.*

THRUST WASHER ALIGNMENT

Measure crankshaft end play. Remove bearing caps and install thrust washer(s) in groove in block; select washers as necessary to bring end play within specifications. Grooved side of washer must face outward.

ENGINE FRONT COVER & OIL SEAL

- 1) Drain cooling system and remove front sub-frame crossmember complete with expansion tank. Remove both cylinder heads and oil pan. Remove alternator and power steering pump. Remove air injection pump and water pump.
- 2) Remove bolts holding pulley to damper and remove pulley. Remove crankshaft damper bolt and strike damper sharply with leather mallet. Remove damper and cone.

XJ12 & "E" TYPE SERIES 3 V12 (Cont.)

3) Pry seal out of timing cover and discard. Remove spacer. Smear new oil seal with engine oil and install oil seal in recess. Tap into place using leather mallet. Reinstall spacer and reverse removal procedure.

4) If entire front cover is to be removed, remove alternator and air pump mounting brackets and remove bolt and serrated washers which hold timing cover to cylinder block. Note positions of bolts and dowel bolts. Remove timing cover.

NOTE - If entire front cover is removed, oil seal may be replaced with front cover removed from engine.

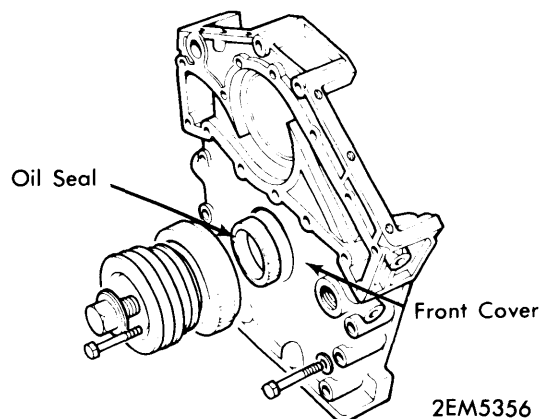

FRONT COVER & FRONT OIL SEAL

| CAMSHAFT | | | |
|----------|--------------------------------|------------------------|-----------------------|
| Engine | Journal Diam. In. (mm) | Clearance In. (mm) | Lobe Lift In. (mm) |
| V12 | 1.0615-1.0620 (26.93-26.94) | .001-.003 (.03-.07) | |

CAMSHAFT REMOVAL

1) With camshaft covers removed, bend back locking tabs and remove two camshaft sprocket retaining bolts. Rotate engine until valve timing gauge can be installed in slot in camshaft. Bend back locking tabs and mark relative position of camshaft to sprocket.

ENGINE OILING

Crankcase Capacity - XJ12: 11.4 qts.
"E" Type: 9.5 qts.
Oil Filter - Full-flow, replaceable element.

OIL PUMP

Pump is of "Epicyclic" type with internal and external gears and crescent type cut off. Drive gear is concentric around crankshaft nose.

Removal - Remove timing cover and timing chain tensioner. Remove spacer from crankshaft and remove timing chain and sprocket from crankshaft. Remove Woodruff key. To install, reverse removal procedure.

2) Remove bolts. Attach sprocket retaining tool (Special Tool JD.40). Do not rotate engine with camshaft disconnected. Progressively loosen camshaft bearing caps nuts starting with center cap and working towards ends. Remove bearing caps, lift camshaft out of tappet block.

| VALVE TIMING | | | | |
|--------------|----------------|-----------------|----------------|-----------------|
| Engine | INTAKE | | EXHAUST | |
| | Open (BTDC) | Close (ABDC) | Open (BBDC) | Close (ATDC) |
| V12 | 17° | 59° | 59° | 17° |

TIMING CHAIN REMOVAL

With timing cover removed, install suitable tool to retain intermediate shaft (jackshaft). Retaining tool (Special Tool JD.39) available for this purpose. Disconnect timing chain from camshaft and intermediate shaft (jackshaft) sprockets. Remove crankshaft sprocket and chain.

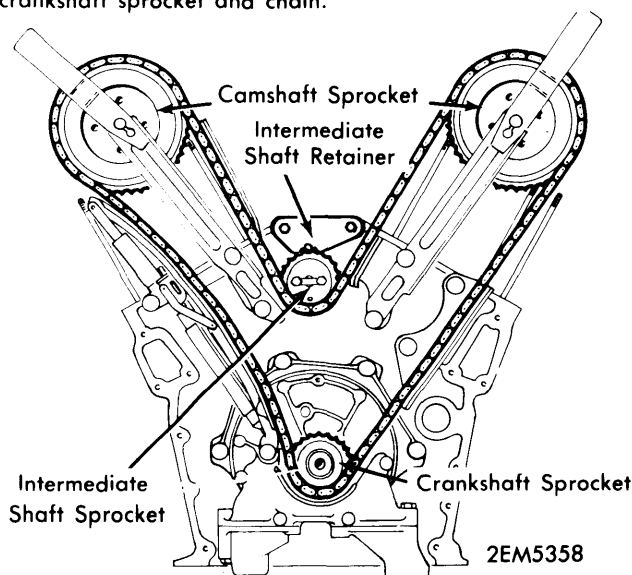

TIMING CHAIN REMOVAL

NOTE - Do not rotate engine with chain removed.

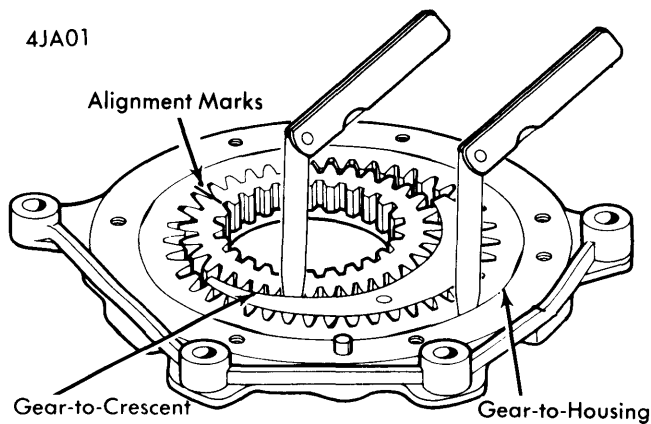

MEASURING OIL PUMP CLEARANCES

XJ12 & "E" TYPE SERIES 3 V12 (Cont.)

Overhaul - 1) Remove eight bolts and lockwashers and remove pump cover from gear housing. Mark drive and driven gear faces to make sure gears are replaced in same position as removed.

2) Remove both gears, and clean thoroughly. Check condition of all gears. Remove burrs with file. Reinstall driven gear and check radial clearance between gear and housing. Checks should not be taken at any of the six radial flats on the gear.

3) Reinstall drive gear and check radial clearance between gear and crescent. Check gear end play by placing straight edge across joint face of housing and measure clearance between straight edge and gear.

4) To reassemble, lubricate all gears with clean oil, check that surfaces are clean, and reverse disassembly procedure.

Oil Pump Specifications

| Application | Clearance ① In. (mm) |
|------------------------------|-------------------------|
| Driven Gear-to-Housing | .005 (.127) |
| Drive Gear-to-Crescent | .006 (.152) |
| Gear End Play | .005 (.127) |

① - Specifications given are maximum allowable.

ENGINE COOLING

WATER PUMP REMOVAL

"E" Type Series 3 - 1) Drain cooling system and remove radiator cowl. Disconnect hose from underside of expansion tank. Disconnect bottom hose from elbow and remove bolts holding elbow to water pump cover. Swing elbow away from pump.

2) Remove alternator drive belts. If equipped with air conditioning, remove compressor drive belt and remove bolt holding pulley arm to compressor mounting bracket.

3) Remove air injection pump drive belt and power steering pump belt. Remove bolt holding steering pump trunnion to mounting bracket.

4) Loosen pump mounting bolts and swing pump away from engine. Remove bolts holding water pump to timing cover and note positions of long and short bolts. Remove water pump assembly. To install, reverse removal procedure.

NOTE - Water pump is sealed unit and no overhaul is possible. Exchange pumps do not come with pulley, therefore pulley must be removed before sending in defective pump. Pulley must then be installed on pump before placing on engine.

XJ 12 - 1) Drain and remove radiator. Remove lower cowl and mounting bracket and lay aside. Remove fan and fan drive unit. Remove fan belt.

2) Remove trunnion adjusting bolt and hardware attaching idler pulley housing. Unscrew two studs. Remove air pump and compressor pump belts.

3) Loosen steering pump pivot bolts enough to draw adjustment bolt from special stud. Remove special stud. Remove ther-

mostat switch housing and bottom hose complete as an assembly. Remove crankshaft pulley and damper assembly.

NOTE - Tap damper with a rawhide mallet to break taper. Do not mislay Woodruff key.

4) Loosen upper hose clamp on engine cross pipe. Remove screw and washers attaching water pump. Pull pump out and downwards to clear cross pipe hose. To install, reverse removal procedure.

Thermostats - Two thermostats; opening temperature is 174-181°F (79-83°C).

Cooling System Capacity - 21.5 qts.

Radiator Cap - 13 psi.

TIGHTENING SPECIFICATIONS

| Application | Ft. Lbs. (mkg) |
|---------------------------------|---------------------|
| Cylinder Head | |
| 7/16" Nuts | 52 (7.2) |
| 3/8" Nuts (XJ12) | 27-28 (3.75-3.9) |
| 3/8" Nuts ("E" Type) | 32 (4.4) |
| Main Bearing Cap | |
| 1/2" Nuts | 62.5 (8.6) |
| 3/8" Nuts | 27-28 (3.75-3.9) |
| Connecting Rod Caps | 40-41 (5.5-5.7) |
| Flywheel | 67 (9.2) |
| Crankshaft Bolt | 125-150 (17.3-20.7) |
| Camshaft Cap Nuts | 9 (1.2) |
| Camshaft Cover Screws | 8.3 (1.15) |
| Union Block-to-Compressor | 10-25 (1.4-3.4) |