

Datsun Engines

B210 4 CYLINDER

GENERAL SPECIFICATIONS										
Year	Displ.		Carburetor	HP at RPM	Torque (Ft. Lbs. at RPM)	Compr. Ratio	Bore		Stroke	
	cu. ins.	cc					in.	mm	in.	mm
1974	78.59	1288	1 x 2-Bbl.	8.5-1	2.87	73	3.03	77

ENGINE IDENTIFICATION

Engine serial and code number is stamped on right rear side of crankcase, below mating surface of crankcase and cylinder head. First three digits are engine code.

Application **Code**
 1288 cc Engine (B210 Model) A13

ENGINE REMOVAL

NOTE — Manufacturer recommends that engine and transmission be removed as an assembly.

- 1) Disconnect battery ground and fusible link. Mark hood hinge location and remove hood. Drain coolant from radiator and engine. Remove radiator shroud, disconnect upper and lower hoses and remove radiator.
- 2) Drain engine oil, then disconnect all electrical wiring and vacuum hoses from engine and transmission. Disconnect fuel line at fuel pump.
- 3) On vehicles with automatic transmission, disconnect wires at inhibitor switch and downshift solenoid. On vehicles with manual transmission, disconnect hydraulic lines and remove clutch slave cylinder.
- 4) Disconnect speedometer and transmission control linkage. Remove gearshift control lever (manual transmission), or disconnect selector range lever (automatic transmission). Disconnect exhaust pipe from manifold then disconnect and remove driveshaft from vehicle.
- 5) Support engine and transmission. Remove bolts securing front motor mounts. Using a suitable hoist, remove engine and transmission from vehicle.

INTAKE MANIFOLD

Removal & Installation — 1) Remove air cleaner and disconnect accelerator cable and choke cable. Disconnect and plug fuel line at carburetor. Disconnect exhaust pipe at exhaust manifold.

2) Remove nuts retaining intake and exhaust manifold to cylinder head and remove. Remove gasket and thoroughly clean mating surfaces. Remove bolts and separate intake and exhaust manifold.

3) To install, use new gasket and reverse removal procedure. Tighten nuts to specifications.

CYLINDER HEAD

Removal — Remove intake manifold as previously outlined. Remove rocker arm cover, rocker arm assembly, and push rods. Remove cylinder head retaining bolts and remove cylinder head.

Installation — 1) Thoroughly clean mating surfaces. Use new gasket with no sealer and install cylinder head. Install cylinder head retaining bolts of smaller diameter and hollow heads in right side center of cylinder head. Install remaining head bolts.

2) Tighten bolts to specification in sequence shown in illustration. Reverse removal procedure to install remaining components. Adjust valve clearance.

2EM5467

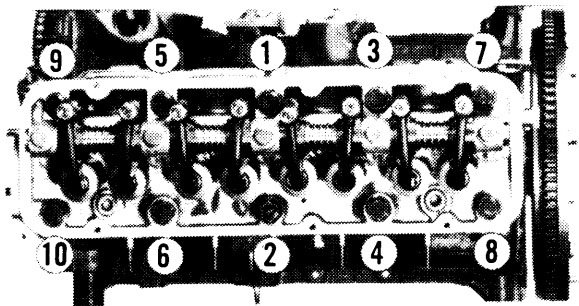

CYLINDER HEAD TIGHTENING SEQUENCE

VALVES							
Engine & Valve	Head Diam. In. (mm)	Face Angle	Seat Angle	Seat Width In. (mm)	Stem Diameter In. (mm)	Stem Clearance In. (mm)	Valve Lift In. (mm)
1288cc Int.	1.46 (37)	45.5°	45°	.0512 (1.3)	.3128-.3134 (7.945-7.960)	.0006-.0018 (.015-.045)	.3114 (7.91)
Exh.	1.18 (30)	45.5°	45°	.0709 (1.8)	.3128-.3134 (7.945-7.960)	.0016-.0028 (.040-.070)	.3236 (8.22)

B210 4 CYLINDER (Cont.)

VALVE ARRANGEMENT

E-I-I-E-E-I-I-E (front to rear).

VALVE GUIDE SERVICING

Check valve stem-to-guide clearance. If clearance is more than .0039" (.1 mm) and valve stem is not worn, valve guide must be replaced. Replace valve guide using the following procedure.

1) Using a suitable driver (ST11320000) press guide from cylinder head using a suitable press. Ream guide hole in cylinder head to .4803-.4807" (12.2-12.211 mm) to install replacement guide.

2) Heat cylinder head to approximately 302-392°F. Install guide using same driver as used for removal. Ream valve stem bore in guide to .3150-.3156" (8.00-8.015 mm) using a suitable reamer (ST11081000). Correct valve seat surface.

2EM5468

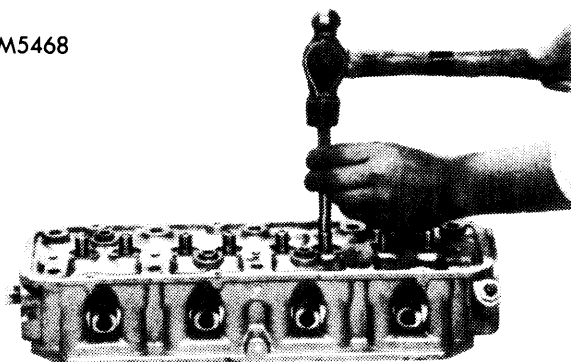

VALVE GUIDE REMOVAL & INSTALLATION

VALVE STEM OIL SEALS

An oil seal is installed on all valve stems inside valve spring. Install seal with large end over valve guide.

VALVE SPRINGS			
Engine	Free Length In. (mm)	PRESSURE Lbs. @ In. (kg @ mm)	
		Valve Closed	Valve Open
All	1.831 (46.5)	52.7 @ 1.52 (23.9 @ 38.7)	129 @ 1.189 (58.5 @ 30.2)

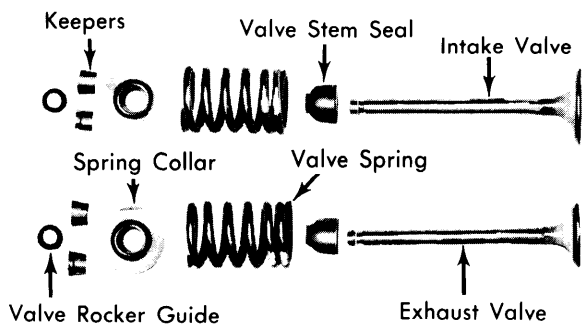

VALVE COMPONENTS

73DA1

VALVE SPRINGS

Removal — With cylinder head removed, compress valve spring using a suitable valve spring compressor (ST102070000) and remove valve keepers. Release spring compressor and remove spring retainer and spring.

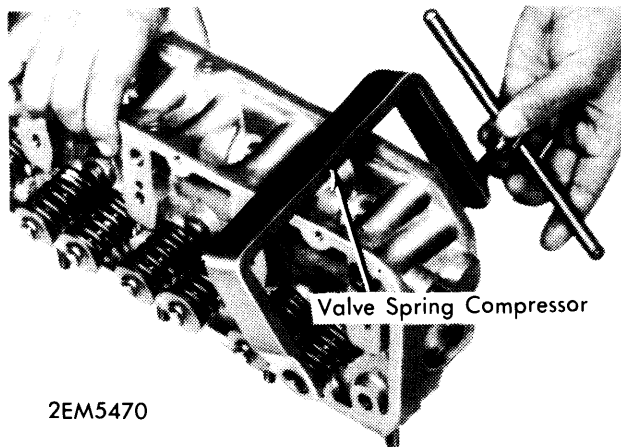

2EM5470

VALVE SPRING REMOVAL

VALVE SPRING INSTALLED HEIGHT

Valve spring installed height is 1.52 (38.7 mm). Check valve spring by applying specified load and measuring spring height. If spring height and pressure does not meet specifications, replace spring.

ROCKER ARM ASSEMBLY

1) Remove valve cover and remove bolts securing rocker arm assembly to cylinder head. Remove rocker arm assembly.

2) Slide off support stands, rocker arms and springs. Thoroughly clean and inspect all components for signs of wear or seizure. Measure rocker arm-to-shaft clearance. Standard clearance is .0008-.0021" (.020-.054 mm). Replace as necessary.

3) If valve contact surface of rocker arm is worn, resurface using a suitable grinder.

4) Reverse disassembly and removal procedures to assemble and install rocker arm assembly. Tighten bolts to specifications and adjust valve clearance.

2EM5471

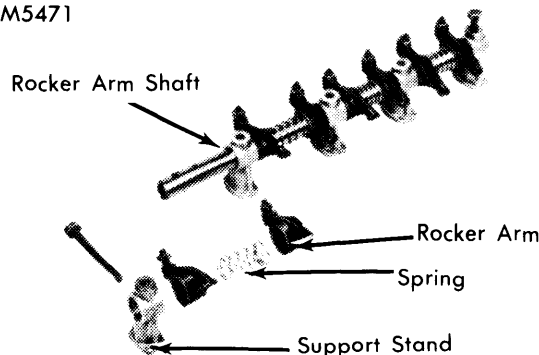

ROCKER ARM ASSEMBLY COMPONENTS

B210 4 CYLINDER (Cont.)

VALVE TAPPET SERVICE

Check valve tappet for signs of wear or seizure. Check clearance between valve tappet and tappet bore in crankcase. If clearance is more than .0059" (.15 mm), replace valve tappet. Standard clearance is .0008-.0020" (.02-.05 mm).

VALVE CLEARANCE ADJUSTMENT

Rotate engine until piston of valves being adjusted is at TDC of compression stroke. Adjust both intake and exhaust valves to .014" (.35 mm) with engine hot.

PISTONS, PINS, RINGS						
Engine	PISTONS		PINS		RINGS	
	Clearance In. (mm)	Piston Fit In. (mm)	Rod Fit In. (mm)	Rings	End Gap In. (mm)	Side Clearance In. (mm)
All	.0009-.0017 (.023-.043)	.0002-.0003 (.006-.008)	.0007-.0013 ⊕ (.017-.034)	1	.0079-.0138 (.20-.35)	.0016-.0028 (.04-.07)
				2	.0079-.0138 (.20-.35)	.0016-.0028 (.04-.07)
				3	.0118-.0354 (.30-.90)	snug snug

⊕ — Interference fit.

PISTON & ROD ASSEMBLY

- 1) Remove cylinder head and oil pan. Remove nuts from connecting rod and remove connecting rod cap with bearing half. Push piston and connecting rod assembly with bearing half up and out through top of crankcase.
- 2) To install piston and connecting rod assembly, thoroughly oil rings, piston and cylinder wall. Make sure ring gaps are situated approximately 180° apart and not on thrust side of piston. Make sure bearing halves are properly seated in connecting rod and cap.
- 3) Install a ring compressor and compress rings. Install piston in cylinder with number on top of piston toward front of engine. With piston installed in cylinder, and connecting rod and bearings seated against crankshaft journal, install rod cap with numbers on the same side as connecting rod. Tighten nuts to specification.
- 4) Install cylinder head and oil pan as previously outlined.

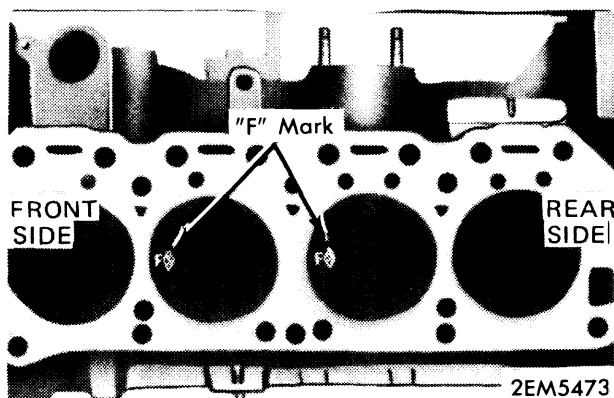

PISTON INSTALLATION

PISTON PIN REPLACEMENT

- 1) Remove piston and connecting rod assembly as previously outlined. Piston pin is press fit in connecting rod and is removed using a press and suitable pin press stand (ST13040000).
- 2) Check piston-to-pin clearance. If clearance is more than .0003" (.008 mm), replace both piston and piston pin. Piston pin should push fit through piston by hand with both piston and pin at room temperature.
- 3) Piston pin should be press fit into connecting rod. If interference fit is less than .0008" (.02 mm), replace connecting rod or piston pin as necessary. If connecting rod is replaced, insure that new rod is within .176 oz (5 g) of defective connecting rod.
- 4) To assemble piston and connecting rod assembly, use same mandrel and driver used for disassembly. Thoroughly oil pin, piston and connecting rod. Install piston on connecting rod so that number on top of piston is pointing toward front of engine and oil squirt hole on connecting rod is toward right side of crankcase.

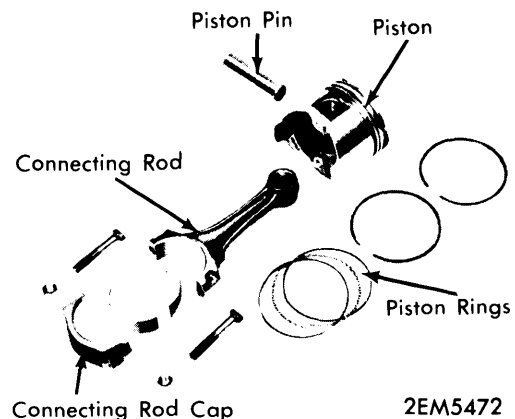

PISTON & CONNECTING ROD ASSEMBLY COMPONENTS

B210 4 CYLINDER (Cont.)

5) Install piston and connecting rod assembly as previously outlined. Install cylinder head and oil pan as previously outlined.

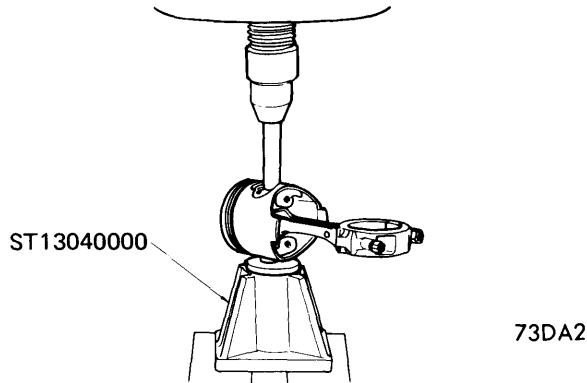

PISTON PIN REMOVAL & INSTALLATION

FITTING PISTONS

1) Check piston-to-cylinder clearance with a feeler gauge and spring tension gauge. With a .0016" (.04 mm) feeler gauge installed between piston and cylinder wall, a force of 1.1-3.3 lbs. (.5-1.5 kg) measured on spring tension gauge, should be needed to extract feeler gauge.

2) Check cylinder bore size, if more than .0079" (.020 mm) over standard size, cylinder must be bored to next oversize. Pistons and rings are available in standard and three oversizes.

Piston Specifications

Application In. (mm)	Piston Size In. (mm)
Std.	2.8727-2.8747 (72.967-73.017)
.020 (0.5)	2.8924-2.8944 (73.467-73.517)
.040 (1.0)	2.9121-2.9140 (73.967-74.017)
.060 (1.5)	2.9318-2.9337 (74.467-74.517)

3) Check piston ring side clearance. Side clearance of all rings should be no more than .0079" (.20 mm). Replace rings or piston if clearance exceeds specification.

4) Check piston ring end gap in cylinders. Push ring into lower cylinder bore with top of piston. Use a feeler gauge to measure end gap. If gap exceeds specification, replace rings.



PISTON RING SIDE CLEARANCE

CRANKSHAFT MAIN & CONNECTING ROD BEARINGS

Engine	MAIN BEARINGS				CONNECTING ROD BEARINGS		
	Journal Diam. In. (mm)	Clearance In. (mm)	Thrust Bearing	Crankshaft End Play In. (mm)	Journal Diam. In. (mm)	Clearance In. (mm)	Side Play In. (mm)
1288	1.9666-1.9671 (49.95-49.96)	.0008-.0024 (.020-.062)	No. 3	.0020-.0059 (.050-.510)	1.7701-1.7706 (44.96-44.97)	.0008-.0020 (.020-.050)	.008-.012 (.20-.30)

MAIN & CONNECTING ROD BEARING SERVICE

1) Remove cylinder head, oil pan, and piston and connecting rod assemblies as previously outlined. Remove alternator and engine mounting bracket from left side. Remove crankshaft pulley, timing chain cover and chain tensioner.

2) Remove crankshaft and camshaft sprockets with timing chain. Remove clutch and flywheel. Remove main bearing caps with bearing halves and rear main bearing oil seal. Remove crankshaft.

Main Bearing Journals

Application In. (mm)	Diameter In. (mm)
Std.	1.9666-1.9671 (49.951-49.964)
.001 (.02)	1.9665-1.9670 (49.949-49.962)
.01 (.25)	1.9567-1.9572 (49.701-49.714)
.02 (.50)	1.9469-1.9474 (49.451-49.464)
.03 (.75)	1.9370-1.9376 (49.201-49.214)
.04 (1.0)	1.9272-1.9277 (48.951-48.964)

Connecting Rod Journals

Application In. (mm)	Diameter In. (mm)
Std.	1.7701-1.7706 (44.961-44.974)
.003 (.08)	1.7670-1.7675 (44.881-44.894)
.005 (.12)	1.7654-1.7659 (44.841-44.854)
.01 (.25)	1.7603-1.7608 (44.711-44.724)
.02 (.50)	1.7504-1.7509 (44.461-44.474)
.03 (.75)	1.7406-1.7411 (44.211-44.224)
.04 (1.0)	1.7307-1.7313 (43.961-43.974)

3) Thoroughly clean and inspect crankshaft. Blow out oil passages with compressed air. Check crankshaft for runout on center main bearing journal. If runout is more than .002" (.05 mm), crankshaft is bent and must be replaced.

4) Check main and connecting rod journals for out-of-round or taper, if more than .0012" (.03 mm), crankshaft must be ground to next undersize. Main and connecting rod bearings are available in the following undersizes.

B210 4 CYLINDER (Cont.)

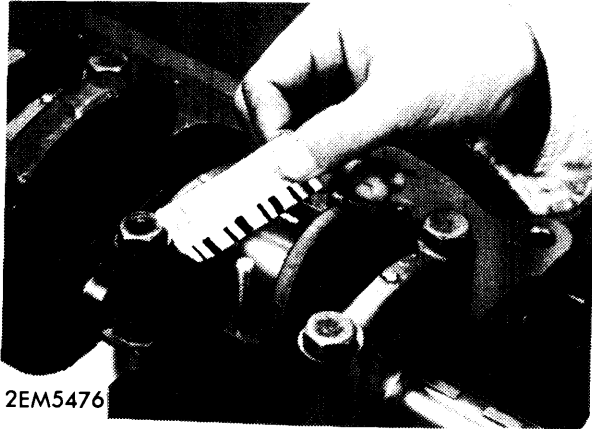

PLASTIGAGE CLEARANCE METHOD

5) Main and connecting rod bearing clearance is checked by the Plastigage method. Place a piece of Plastigage wire on journal and install main cap or rod cap and tighten to specification. Remove main or rod cap and compare flattened wire to scale on back of Plastigage package.

6) Install main bearing halves in crankcase and main bearing caps. Apply oil to main bearing surface and install crankshaft. Install main bearing caps with arrow pointing toward front of motor. Install rear main bearing cap with oil seal. See *Rear Main Bearing Oil Seal Service*. Tighten main bearing cap bolts to specification.

7) Check crankshaft end play. See *Thrust Bearing Alignment*. Install timing chain in correct position with crankshaft and camshaft sprockets. See *Valve Timing*. Install remaining components in reverse of removal order or as previously outlined.

THRUST BEARING ALIGNMENT

Thrust bearing is installed on number three main bearing journal. Check crankshaft end play by inserting a feeler gauge between flange of thrust bearing and crankshaft. End play should be more than .0118" (.30 mm).

2EM5477

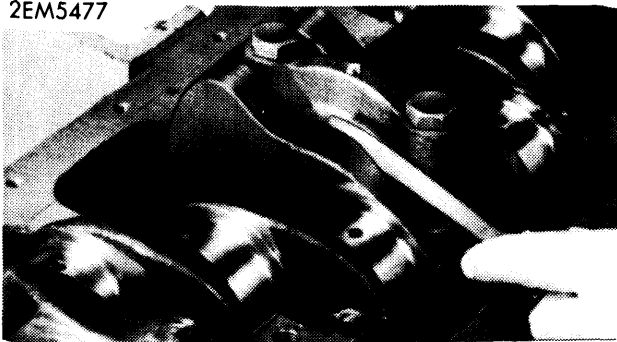

CRANKSHAFT END PLAY

REAR MAIN BEARING OIL SEAL SERVICE

Apply sealer to corners of crankcase that holds rear main bearing cap. Apply lithium grease to sealing edge on seal and install seal. Install rear main bearing cap and tighten bolts to specifications.

2EM5478

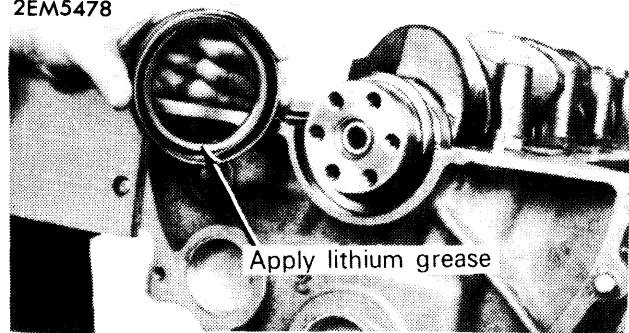
REAR MAIN BEARING OIL SEAL
INSTALLATION

ENGINE FRONT COVER & OIL SEAL

1) Remove drive belt, fan and water pump pulley. Remove water pump and crankshaft pulley. Remove oil pan and front engine cover.

2) Replace seal in cover whenever cover is removed. Thoroughly clean mating surfaces and apply sealer to both sides of gasket. Install gasket and cover.

3) Tighten bolts and nuts to specifications. Reverse removal procedure to install remaining components.

CAMSHAFT

Engine	Journal Diam. In. (mm)	Clearance In. (mm)	Lobe Lift In. (mm)
All No. 1	1.7237-1.7242 (43.78-43.80)	.0015-.0024 (.037-.060)	Int. .222 (5.65)
2	1.7041-1.7046 (43.28-43.30)	.0011-.0020 (.027-.050)	Exh. 2.33 (5.92)
3	1.6844-1.6849 (42.78-42.80)	.0016-.0025 (.040-.063)	
4	1.6647-1.6652 (42.28-42.30)	.0011-.0020 (.029-.050)	
5	1.6224-1.6229 (41.21-41.22)	.0015-.0024 (.037-.060)	

Removal - 1) Remove engine front cover as previously outlined. Remove fuel pump and oil pump with filter. Remove timing chain tensioner and remove timing chain with sprockets. Remove two bolts from camshaft lock plate and pull camshaft from crankcase.

2) Thoroughly clean and inspect camshaft for wear or scoring. Check runout of camshaft using a dial indicator on center bearing journal. If runout exceeds .002" (.05), replace camshaft.

3) Check journal diameter, if diameter is less than .0039" (.10 mm) from standard, camshaft journals must be ground to next undersize. Bearings are available in standard and three undersizes.

4) Check camshaft end play. Install camshaft sprocket on camshaft and check runout using a dial indicator. If runout exceeds .0039" (.10 mm), replace sprocket.

B210 4 CYLINDER (Cont.)

2EM5480

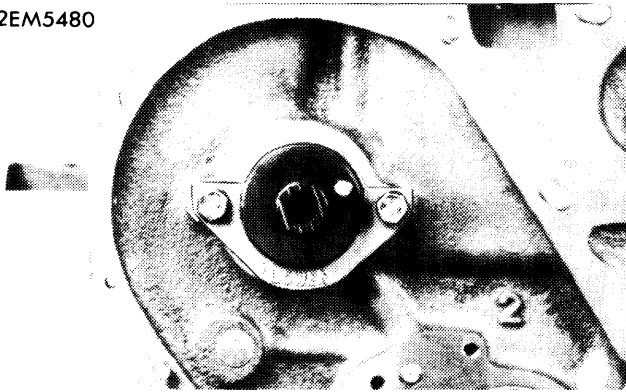

CAMSHAFT LOCK PLATE INSTALLATION

Installation — 1) Insert camshaft into crankcase and position lock with word "lower" at bottom. Tighten bolts to specification. Temporarily install camshaft and crankshaft sprockets to check installed height.

2) Measure height of both sprockets. If difference in height is more than .020" (0.5 mm), install an adjusting washer under crankshaft sprocket to obtain correct height. Adjusting washers are .006" (.15 mm) thick. Remove sprockets and reinstall with timing chain and sprockets in correct position.

3) Install engine front cover as previously outlined. To install remaining components, reverse removal order.

CAMSHAFT BEARING REPLACEMENT

1) With camshaft removed, check journal diameter and bearing inside diameter. If journal measurement is within tolerance and clearance between camshaft journals and bearings exceeds .0059" (.15 mm), bearings must be replaced.

2) Remove and install appropriate bearings in crankcase using a suitable driver (ST16110000). Make sure oil holes in bearings align with oil holes in crankcase. Bearings must be line bored after installation. Install taper plug in crankcase using sealer. Install camshaft as previously outlined.

ENGINE OILING

ENGINE OILING SYSTEM

Oil is circulated through engine by pressure provided by a trochoid rotor type pump. Oil pump is mounted on side of crankcase and driven by camshaft. Oil is drawn from oil pan by oil pump and into full flow oil filter mounted under oil pump. Oil is then pumped into main oil gallery of crankcase where it is distributed to crankshaft journals, timing chain tensioner and squirter that lubricates timing chain. Oil is circulated from crankshaft main bearing journals to camshaft journals and from center camshaft journal to rocker arm shaft to lubricate rocker arms and valves. Cylinder walls and piston pins are lubricated by oil squirted from squirt hole in connecting rod.

Crankcase Capacity — 3.4 qts. (with filter).

Oil Filter — Full-flow, replaceable element.

CAMSHAFT END THRUST

Check clearance between lock plate and front portion of camshaft, if more than .0039" (.10 mm), replace lock plate.

VALVE TIMING				
Engine	INTAKE		EXHAUST	
	Open (BTDC)	Close (ALDC)	Open (BLDC)	Close (ATDC)
All	14°	54°	56°	20°

TIMING CHAIN REPLACEMENT

1) Remove engine front cover as previously outlined. Remove timing chain tensioner and bolt securing camshaft sprocket to camshaft. Pull off sprocket with timing chain.

2) Thoroughly clean and inspect chain for wear or damage. Make sure links are not stretched. Replace chain if necessary.

3) To install, reverse removal procedure. Make sure timing chain and sprockets are correctly timed when installed. See *Valve Timing*.

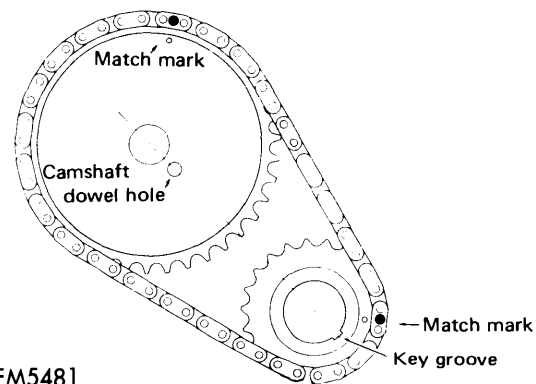

TIMING CHAIN INSTALLATION

VALVE TIMING

Marks on timing chain must line up with marks on crankshaft and camshaft sprockets (see illustration).

Oil Pressure — 13-17 psi at Idle, 54-60 psi Max.

Pressure Relief Valve — Nonadjustable.

OIL PUMP

1) To remove oil pump, drain engine oil, remove front suspension stabilizer bar and splash shield. Remove oil filter. Remove bolts securing oil pump to crankcase and remove oil pump.

2) Remove bolt securing pump cover to pump body and separate cover from body. Remove inner and outer rotors with pump drive. Remove plug from cover and pull out pressure regulator valve spring and piston.

3) Thoroughly clean and inspect all components for wear or scoring. Check side and tip clearance between rotors. Check clearance between outer rotor and pump body. If clearances are excessive, replace components as necessary (see specifications).

Datsun Engines

B210 4 CYLINDER (Cont.)

ENGINE OILING (Cont.)

4) Reverse disassembly and removal procedures to assemble and install oil pump. Use new gaskets and tighten bolts to specification.

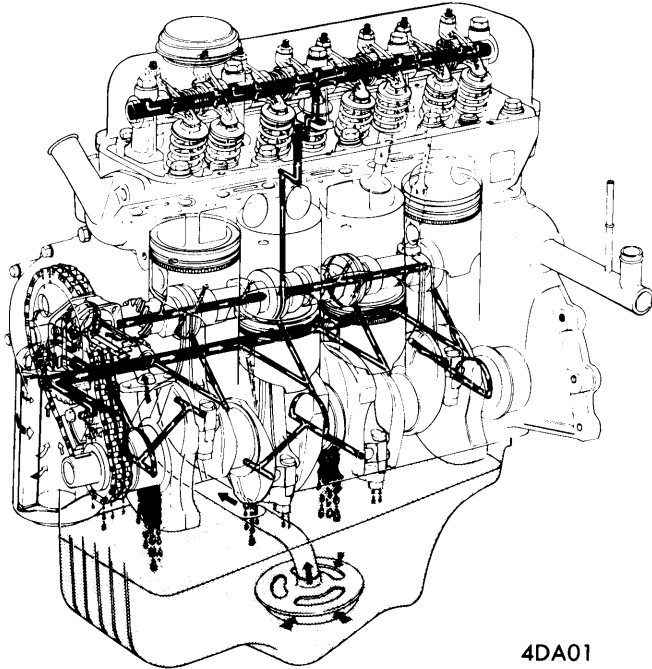

ENGINE OILING SYSTEM

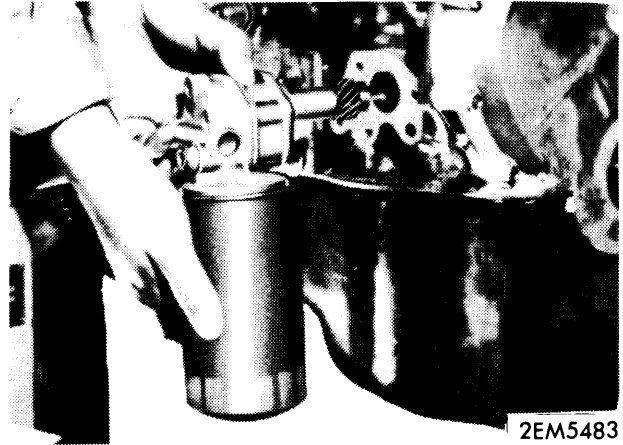

OIL PUMP REMOVAL

Oil Pump Specifications

Application	In. (mm)
Rotor-to-Rotor Side Clearance002-.0047 (.05-.12)
Rotor-to-Tip Clearance0016-.0047 (.04-.12)
Rotor-to-Pump Body0059-.0083 (.15-.21)
Regulator Valve Spring	
Free Length	1.71 (43.49)
Pressure Length	1.19 (30.3)

ENGINE COOLING

WATER PUMP

1) Drain cooling system and remove fan belt. Remove fan and pulley. Remove bolts and nuts securing water pump to engine front cover and remove water pump.

2) To install, reverse removal procedure. Thoroughly clean mating surfaces and use new gasket.

Thermostat — Opens at 177-183°F.

Cooling System Capacity — 5 $\frac{3}{16}$ qts. (with heater).

Radiator Cap — 13 psi.

TIGHTENING SPECIFICATIONS

Application	Ft. Lbs. (mkg)
Cylinder Head	51-54 (7.0-7.5)
Connecting Rod	23-27 (3.2-3.8)
Main Bearing Caps	36-43 (5.0-6.0)
Camshaft Sprocket	29-35 (4.0-4.8)
Camshaft Lock Plate	3-4 (0.4-0.5)
Timing Chain Tensioner	4.3-5.8 (0.6-0.8)
Front Cover	3.6-5.1 (.5-.7)
Oil Pan	2.9-4.3 (.4-.6)
Oil Pump	6.5-10.1 (.9-1.4)
Rocker Arm Shaft	14-18 (2.0-2.5)
Manifolds	6.5-10 (.9-1.4)
Crankshaft Pulley	108-145 (15-20)
Flywheel	54-61 (7.5-8.5)
Oil Strainer	6.5-10 (.9-1.4)