

## 2002 4 CYLINDER

GENERAL SPECIFICATIONS										
Year	Displ.		Carburetor	HP at RPM	Torque (Ft. Lbs. at RPM)	Compr. Ratio	Bore		Stroke	
	cu. ins.	cc					in.	mm	in.	mm
1974										
2002, 2002A	121.44	1990	2-Bbl.	113@5800	115@3500	8.3:1	3.504	89	3.150	80
2002tii	121.44	1990	①	147@5800	130@4500	9.5:1	3.504	89	3.150	80

① — Kugelfisher mechanical fuel injection.

### ENGINE REMOVAL

**All Models Except 2002 tii** — 1) Remove air cleaner hoses and tubes. Remove air cleaner. Disconnect ground leads from battery and engine. Remove alternator and starter positive cables.

2) On 2002A models, disconnect cables from choke and thermo-start valve. Disconnect plug from starter lock. Pull wiring harness out of retainer at gear box.

3) Remove radiator. Disconnect fuel line at fuel pump. Disconnect wire from thermometer sensor. Remove vacuum line with non-return valve from union. Disconnect heater hose from intake manifold.

4) Disconnect return spring, clamp spring and control rod on carburetor from support on firewall. Loosen clamp and pull out choke cable.

5) On 2002A models, disconnect return spring and vertical pull rod from carburetor linkage (near firewall end of intake manifold). Lift out wire retainer from ball end of torsion shaft, and lift out shaft.

6) Detach wires from oil pressure switch and from distributor (terminal "1"). Remove distributor cap, pull out No. 4 spark plug wire, and remove rotor. Disconnect hot water hose from rear of head.

7) Detach clutch pedal pull rod from one end of intermediate shaft and bearing support from other end. Withdraw intermediate shaft with push rod. Before dismantling further, check clutch for wear: push release lever in direction of travel up to stop. Measure distance of lever movement; if less than .197" (5 mm) replace clutch. On 2002 models, pull back clutch collar, lift out circlip, and pull slave cylinder out forward.

8) Slacken nut on left side engine mount. Remove gearshift selector lever. On 2002A models, remove "C" clip retainer and detach selector rod from lever.

9) Disconnect exhaust pipe support bracket, then detach exhaust pipe from manifold. Remove attaching nuts and disconnect propeller shaft at transmission. Loosen attaching bolts at propeller shaft center bearing.

**NOTE** — To avoid the problem of loud booming noises coming from exhaust pipe after installation, use the following sequence of mounting: Attach exhaust pipe to manifold. Loosen retaining plate mounting bolts and press exhaust pipe support (tension free) against exhaust pipe. Tighten retaining plate to transmission and support. Tighten support to exhaust pipe.

10) Attach suitable lifting hoist to engine. Remove crossmember. Disconnect speedometer cable and back-up light wires.

11) Loosen nut on right engine mount. Remove windshield washer reservoir. Lower transmission and lift engine out of vehicle to the right. To install, reverse removal procedures.

**2002tii** — 1) Disconnect negative battery lead. Remove transmission. Disconnect leads from alternator. Remove radiator and air cleaner.

2) Disconnect negative lead from battery box. Disconnect fuel hose from injector pump and wire from thermo-time switch. Remove fuel filter from front panel.

3) Disconnect vacuum hose air distribution manifold. Disconnect lead from start valve and clamps on cylinder head.

4) Disconnect accelerator linkage and starter cable. Remove heater and overflow hoses from cylinder head. Disconnect fuel overflow hose.

5) Remove wires from distributor and oil pressure switch. Pull induction transmitter from coil. Remove distributor cap and rotor.

6) Attach suitable lifting hoist to engine. Remove windshield washer reservoir. Remove right and left engine mounting nuts. Disconnect harness cable clamp near left engine mount. Lift engine out of vehicle. To install, reverse removal procedures.

### CYLINDER HEAD

**Removal** — 1) Pull off breather tube, then pull hose with connector out of tube. Dismantle air cleaner assembly. Disconnect ground lead from battery. Drain cooling system. Loosen clamp screw and pull out choke cable.

2) Detach clamp spring, return spring, and wire retainer from throttle linkage. Pull torsion shaft toward firewall until ball end is free. Pull torsion shaft out in a forward direction.

3) Remove vacuum hose (with check valve) and water hoses from intake manifold. Pull out dipstick tube. Detach fuel hose from fuel pump and cable from engine coolant switch. Remove water hoses from manifold branch.

4) Pull cable off oil pressure switch and terminal "1" of distributor. Remove distributor cap. Pull No. 4 spark plug wire out of cap, and detach ignition cable. Remove water hose from rear of cylinder head.

## 2002 4 CYLINDER (Cont.)

5) Remove upper transmission cover. Adjust No. 1 piston to TDC. Distributor rotor must point at notch in distributor housing. The timing indicator must point at second notch on pulley when turning clockwise (see illustration).

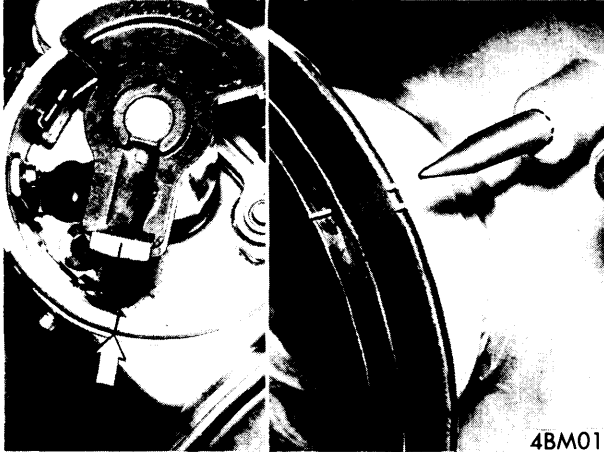

SETTING NO. 1 PISTON AT TDC

6) Remove chain tensioner piston from camshaft sprocket. Remove sprocket. Remove exhaust pipe from exhaust manifold. Unscrew cylinder head bolts in reverse of tightening sequence, and remove cylinder head.

**Installation** — Ensure installation guides extend .197" (5 mm) beyond cylinder head mounting surface. Also be sure there is no oil in blind holes, or head bolts will not be able to exert required holding force on head. Replace cylinder head and

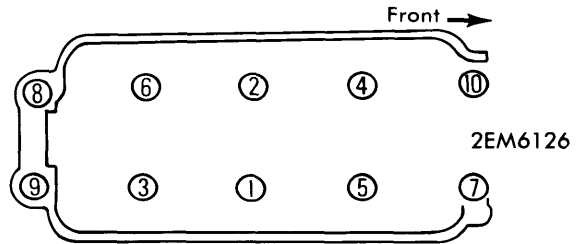

CYLINDER HEAD TIGHTENING SEQUENCE

components in reverse of removal procedure, tightening head bolts, in a series of steps, according to sequence illustrated (with engine at normal operating temperature).

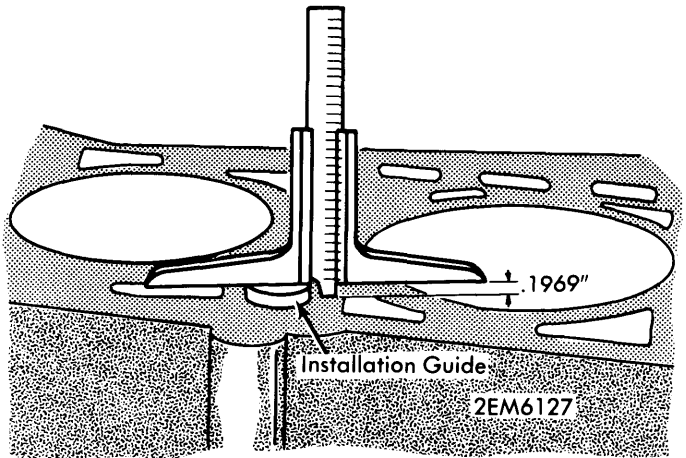

MEASURING HEAD INSTALLATION GUIDES

VALVES							
Engine & Valve	Head Diam. In. (mm)	Face Angle	Seat Angle	Seat Width In. (mm)	Stem Diameter In. (mm)	Stem Clearance In. (mm)	Valve Lift In. (mm)
2002 Intake	1.732 (44)	45°	46°	.040 (1.02)	.3134-.3140 (7.96-7.98)	.0015-.002 (.038-.05)	....
Exhaust	1.496 (38)	45°	46°	.060 (1.52)	.3128-.3134 (7.95-7.96)	.0015-.002 (.038-.05)	....

### VALVE ARRANGEMENT

Right Side — All exhaust.

Left Side — All intake.

### ROCKER ARM ASSEMBLY

**Removal** — 1) With camshaft removed, push back thrust ring and rocker arm so rocker shaft circlip may be removed (see illustration). Remove distributor mounting flange.

2) Drive out rocker shafts with a punch. Remove rocker arms, springs and thrust rings.

**NOTE** — Rocker shaft on intake side is open at rear. Exhaust rocker shaft is plugged.

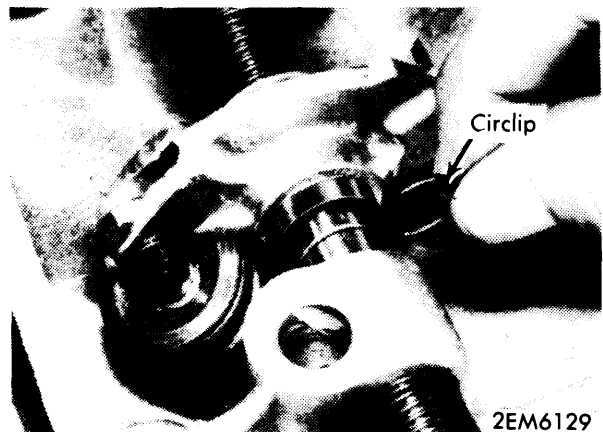

ROCKER SHAFT CIRCLIP LOCATION

## 2002 4 CYLINDER (Cont.)

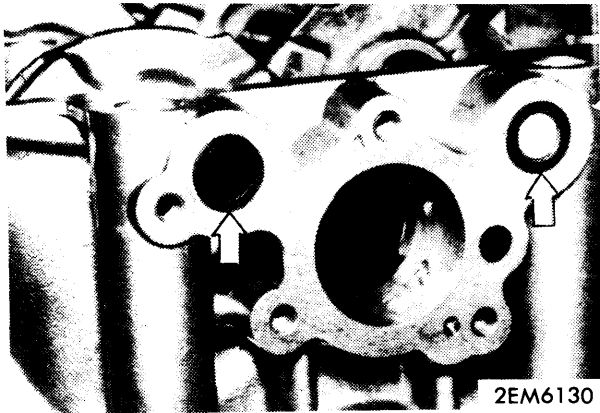

**REAR EXHAUST ROCKER SHAFT PLUG**

3) Replace rocker arms with loose slide pads.

*NOTE* — Two styles of rocker arms are available. Old style rocker arm without bushing and with .472" (12 mm) wide slide pad. Rocker shaft oil hole faces downward. New style rocker arm with bushing and .433" (11 mm) wide slide pad has two rocker shaft oil holes horizontal.

**Installation** — Replace springs, rocker arms and thrust rings. Insert rocker shafts and align shafts so locating pins may be installed. Replace rocker shaft circlips.

VALVE SPRINGS			
Engine	Free Length In. (mm)	PRESSURE Lbs. @ In. (kg @ mm)	
		Valve Closed	Valve Open
2002	1.713 (43.5)	63.9 @ 1.48 (24 @ 37.6)	154 @ 1.12 (70 @ 28.5)

### VALVE SPRING SERVICE

Remove valve keepers and collar. Check spring for wear or fatigue. Replace worn springs with green marked springs only. Install spring, collar and keepers.

### VALVE GUIDE SERVICE

1) Check valve guide for wear. If replacement is necessary, press out guide toward combustion chamber. Measure guide bore in cylinder head. If bore exceeds .5512" (14 mm), ream head and install oversize guide.

2) Heat cylinder head to 428-482°F (220-250°C) and press in new guide from top side until tapered groove end protrudes .591" (15 mm) above surface. Ream guide to obtain specified clearance. Valve guides are available in the following sizes (O.D. measurements given):

Application	Valve Guide Sizes	Guide O.D. In. (mm)
Standard		.5532 (14.05)
1st Oversize		.5551 (14.10)
2nd Oversize		.5590 (14.20)
3rd Oversize		.5630 (14.30)

### VALVE SEAT SERVICE

Refer to illustration and note minimum valve seat and valve head thicknesses. If either specification is not met, replace necessary component. When replacing valve seat, remove old seat by turning out with suitable cutting tool. Drill out bore to appropriate oversize: note valve seat oversize to be used and rebore head allowing for shrink-fit of replacement seat. When installing new seat, heat head to approximately 392°F (200°C) and chill valve seat to approximately -94°F (-70°C). Replacement seats are available in the following oversizes:

#### Replacement Valve Seat Rings

Application	Measurement In. (mm)
Intake	
1st Oversize	1.864 (47.35)
2nd Oversize	1.872 (47.55)
Exhaust	
1st Oversize	1.589 (40.35)
2nd Oversize	1.597 (40.55)

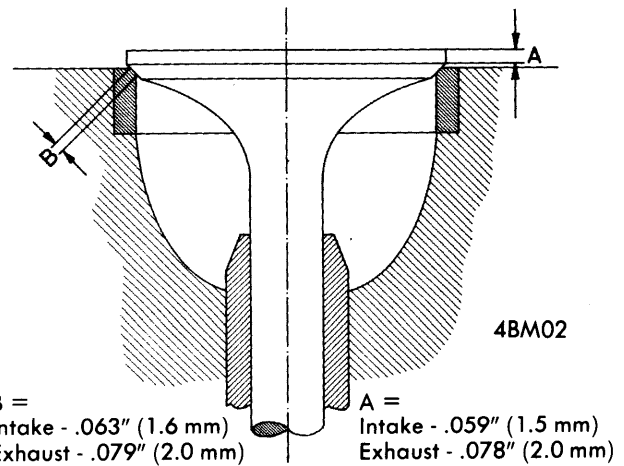

**CHECKING VALVE & SEAT WIDTHS**

### VALVE CLEARANCE ADJUSTMENT

Adjust valves in firing order sequence (1-3-4-2) with No. 1 cylinder at TDC of compression stroke. Using a feeler gauge between rocker eccentric and valve stem, set clearance to .008-.010" (.20-.25 mm) with engine hot and to .006-.008" (.15-.20 mm) with engine cold. Loosen nut of rocker eccentric, insert a rod in eccentric hole and rotate until proper clearance is obtained (see illustration).

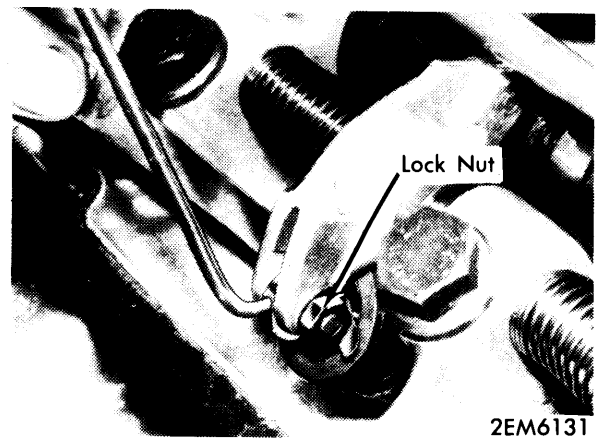

**TAPPET ADJUSTMENT**

# BMW Engines

## 2002 4 CYLINDER (Cont.)

PISTONS, PINS, RINGS						
Engine	PISTONS		PINS		RINGS	
	Clearance In. (mm)	Piston Fit In. (mm)	Rod Fit In. (mm)	Rings	End Gap In. (mm)	Side Clearance In. (mm)
2002	.0015 (.04)	.0015 (.04)	.0001-.0004 (.003-.010)	No. 1	.0118-.0177 (.30-.45)	.0006-.0011 (.015-.029)
				No. 2	.0118-.0177 (.30-.45)	.0005-.0010 (.012-.026)
				No. 3	.0098-.0157 (.25-.40)	.0004-.0010 (.011-.025)

### OIL PAN REMOVAL

With engine installed, remove stabilizer bar and drain engine oil. Remove bolts from oil pan. Remove nuts from both engine mounts and lift engine slightly. Rotate No. 4 piston to TDC and slide oil pan forward and out. Coat crankcase ends where timing cover and rear main bearing cover join crankcase with sealing compound before reassembly.

### PISTON & ROD ASSEMBLY

**Removal** — After removing oil pan and cylinder head, rotate crankshaft to TDC of piston and rod assembly to be removed. Unscrew connecting rod cap nuts and push assembly out top of engine. Replace worn or damaged parts as necessary, according to appropriate service procedure indicated in this article.

**Installation** — Place rings on piston with marking "TOP" facing upward and ring end gaps 180° apart. Install piston with arrow facing forward and oil hole in wrist pin end of connecting rod facing timing chain. Ensure connecting rod and bearing cap numbers match, with No. 1 rod nearest the timing chain.

### CONNECTING ROD BUSHING

- 1) Remove circlips and push out wrist pin. Check for wear in piston and connecting rod. If rod bushing is worn, press out old bushing and press in new bushing with ends 90° to oil hole.
- 2) Wrist pins come in two diameters, white coded wrist pin with "W" stamped on piston crown or black coded wrist pin with "S" stamped on piston crown.
- 3) Drill oil holes in bushing and ream bushing diameter to specifications. Piston pin should be a light push fit through connecting rod bushing.

### FITTING PISTONS

Piston crowns are marked with arrow for direction of installation and a "+", "-", or no sign to show weight classification. All

pistons should have same weight mark. Measure piston and cylinder diameter to determine clearance (see specifications). Measure piston diameter at 90° to wrist pin bore near bottom of piston skirt, see following table for distance from bottom of piston.

#### Piston Measuring Location

Piston Make	2002 <sup>tii</sup> In. (mm)	2002, A In. (mm)
Mahle	.65 (16.5)	.63 (16.0)
KS	.92 (23.4)	.63 (16.0)
Nural		.62 (15.9)

**NOTE** — Two types of pistons may be encountered, those with standard oval crown and those which are modified for hemispherical combustion chamber (enlarged crown). Be sure to note this when obtaining replacement pistons.

Pistons come in standard, intermediate, .010" and .020" oversizes. Pistons are graded in all sizes with letters A, B, and C.

#### Piston Sizes

Application (Grade)	Diameter In. (mm)
Standard	
A	3.5024 (88.96)
B	3.5028 (88.97)
C	3.5032 (88.98)
Intermediate	
A	3.5055 (89.04)
B	3.5059 (89.05)
C	3.5063 (89.06)
.010" (.25 mm) Oversize	
A	3.5122 (89.21)
B	3.5126 (89.22)
C	3.5130 (89.23)
.020" (.51 mm) Oversize	
A	3.5221 (89.46)
B	3.5225 (89.47)
C	3.5229 (89.48)

CRANKSHAFT MAIN & CONNECTING ROD BEARINGS								
Engine	MAIN BEARINGS				CONNECTING ROD BEARINGS			
	Journal Diam. In. (mm)	Clearance In. (mm)	Thrust Bearing	Crankshaft End Play In. (mm)	Journal Diam. In. (mm)	Clearance In. (mm)	Side Play In. (mm)	
2002	Red	2.1646-2.1650 (54.98-54.99)	.0011-.0027 (.028-.068)	Center	.0033-.0068 (.08-.17)	1.8888-1.8894 (47.95-47.99)	.0009-.0027 (.023-.069)	....
	Blue	2.1642-2.1646 (54.97-54.98)	.0011-.0026 (.028-.066)		.0033-.0068 (.08-.17)	1.8888-1.8894 (47.95-47.99)	.0009-.0027 (.023-.069)	....

## 2002 4 CYLINDER (Cont.)

### MAIN BEARING SERVICE

Plastigage method is used to determine connecting rod and main bearing journal clearances. Standard or undersize crankshafts are marked red or blue. Color coded inserts must agree with crankshaft color code (see illustration). The following table shows color code and undersizes available:

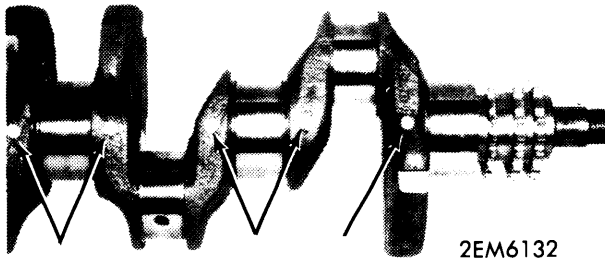

ORIGINAL CRANKSHAFT MARKS

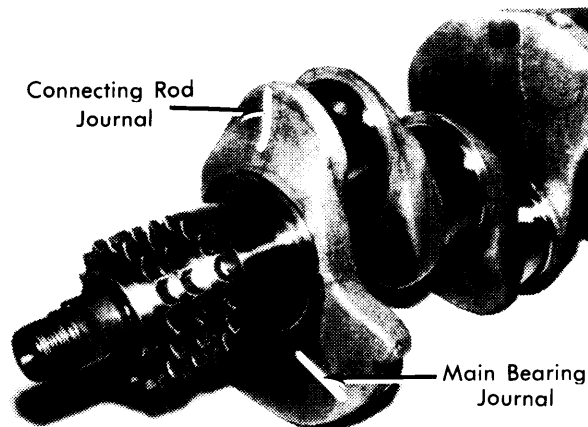

UNDERSIZE CRANKSHAFT MARKS

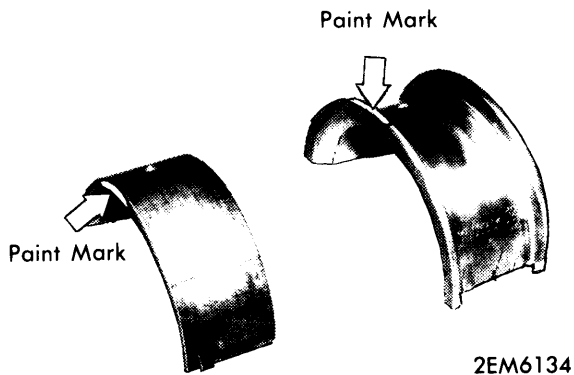

BEARING INSERT CODING (Red or Blue)

### Main Bearing Journal

Application	Red	Blue
	In. (mm)	In. (mm)
Original.....	2.1646-2.1650 (54.98-54.99)	2.1642-2.1646 (54.91-54.98)
1st Stage.....	2.1547-2.1551 (54.73-54.74)	2.1543-2.1547 (54.72-54.73)
2nd Stage.....	2.1449-2.1453 (54.48-54.59)	2.1445-2.1449 (54.47-54.48)
3rd Stage.....	2.1350-2.1354 (54.23-54.24)	2.1346-2.1350 (54.22-54.23)

### Connecting Rod Journal

Application	Diameter
	In. (mm)
Original .....	1.888-1.9994 (47.98-47.99)
1st Stage .....	1.8789-1.8795 (47.72-47.73)
2nd Stage .....	1.8681-1.8697 (47.45-47.49)
3rd Stage .....	1.8592-1.8598 (47.22-47.24)

### THRUST BEARING ALIGNMENT

Attach a dial indicator to crankcase with shaft touching flywheel. Move flywheel in and out to determine endplay of crankshaft. If endplay is excessive, replace center main bearing inserts.

### REAR MAIN BEARING OIL SEAL SERVICE

With flywheel removed, unscrew six attaching bolts from rear crankshaft seal holder. Carefully run a knife blade between seal holder and oil pan gasket to break seal. Remove seal holder and press out old seal, press in new seal. Coat oil pan gasket at either side with sealing compound and replace seal holder.

### ENGINE FRONT COVER & OIL SEAL

- 1) Remove radiator and loosen alternator adjusting brackets. Remove fan belt. Detach cover plate from transmission.
- 2) Using suitable tool (6069), lock flywheel ring gear. Unscrew nut from pulley hub and remove pulley. Using a suitable puller, extract oil seal and replace with new seal.
- 3) Remove bolts attaching timing cover. Insert a knife blade between cover and oil pan gasket to break seal. Lift off timing cover. To install, reverse removal procedures.

CAMSHAFT			
Engine	Journal Diam. In. (mm)	Clearance In. (mm)	Lobe Lift In. (mm)
2002 ①			
No. 1	1.3763-1.3770 (34.96-34.98)	.0013-.0029 (.033-.074)	.2764 (7.02)
No. 2	1.6519-1.6526 (41.96-41.98)	.0013-.0029 (.033-.074)	.2264 (7.02)
No. 3	1.6912-1.6919 (42.96-42.98)	.0013-.0029 (.033-.074)	.2264 (7.02)

① — End play is .0008-.005" (.020-.127 mm).

## 2002 4 CYLINDER (Cont.)

## CAMSHAFT

**Removal** – 1) Mark relative position of vacuum advance unit for reassembly reference. Remove cylinder head, as previously described. Unbolt and remove distributor. Attach head assembly to suitable holding tool (6025-1). Remove oil pipe from top of head.

2) Remove fuel pump, and partially pull fuel pump plunger out of head. Adjust valve clearance to maximum possible. Attach a suitable compression frame (6025-2) to preload the rocker assembly. Check end play between guide plate and camshaft. Remove guide plate and carefully withdraw camshaft.

**Installation** – When replacing camshaft, note the following: After guide plate has been installed, it must be possible to easily rotate the camshaft. Make sure that notch in flange is flush with cast projection in head. Adjust valve clearances. Note position of oil pipe sealing rings. When replacing distributor, turn rotor counterclockwise approximately  $1\frac{1}{2}$ " (35 mm) from notch in distributor housing, then bring distributor drive into mesh with camshaft drive. Ensure vacuum advance has been located in original position. Adjust ignition timing.

VALVE TIMING				
Engine	INTAKE		EXHAUST	
	Open (BTDC)	Close (ABDC)	Open (BBDC)	Close (ATDC)
2002 <sup>Ⓢ</sup>	18°	66°	66°	18°

<sup>Ⓢ</sup> – With .011" clearance between cam base circle and rocker pad.

## TIMING CHAIN REPLACEMENT

**Removal & Installation** – 1) Remove cylinder head, oil pan and water pump. Remove cover plate on transmission. Lock flywheel with suitable tool (6069).

2) Unscrew nut on pulley hub and remove pulley. Remove alternator and mounting brackets. Remove timing cover.

3) Mark direction of timing chain rotation if original chain is to be reinstalled. If new chain is installed, replace timing sprockets. To install, reverse removal procedures.

## VALVE TIMING

Rotate engine to TDC of No. 1 piston. Position camshaft so that timing mark on camshaft flange is straight up and locating pin hole is straight down. Without moving crankshaft or camshaft, install camshaft sprocket so that it engages locating pin hole in camshaft flange.

## TIMING CHAIN TENSIONER SERVICE

1) Unscrew tensioner plug and remove piston and spring.

**CAUTION** – Tensioner plug is under high spring pressure, use care when removing plug.

2) Press piston out of sleeve. Remove ball bearing and perforated disc. Clean all parts thoroughly.

3) Reassemble sleeve, perforated disc, ball bearing and piston, making sure perforated disc does not block bleed slots (see illustration).

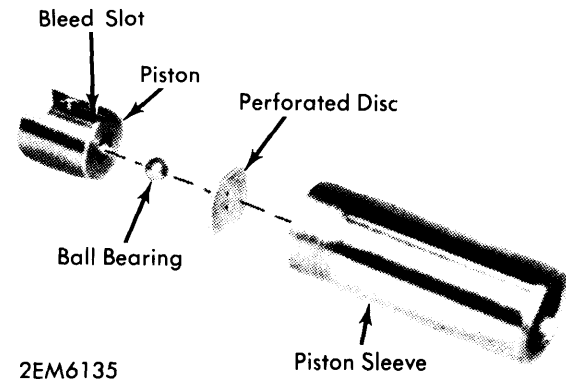

## CHAIN TENSIONER PISTON ASSEMBLY

4) Install piston in tensioner body. Place spring with tapered end facing tensioner plug. Screw tensioner plug slightly into tensioner body. Fill oil pocket with engine oil and move tensioner rail back and forth until oil comes out around plug threads. Tighten tensioner plug.

## ENGINE OILING

## ENGINE OILING SYSTEM

A chain driven gear or rotor type oil pump pressure feeds oil to a full-flow oil filter. From oil filter, oil is fed through passages to all moving parts of engine.

**NOTE** – If vehicle is equipped with a gear-type pump, manufacturer recommends substitution of this pump with a rotor type, when replacement is required. Note special instruction during installation.

**Crankcase Capacity** – 4.5 qts. (4.25 liters) with filter.

**Oil Filter** – Full-flow; replace 4,000 miles.

**Normal Oil Pressure** – 56.9 psi (4 atm) at 4,000 RPM.

**Pressure Regulator Valve** – Non-adjustable.

## OIL PUMP

1) Remove oil pan and oil pump sprocket. Remove bolts attaching pump pick-up. Remove two bolts mounting pump to crankcase and lift out pump.

## 2002 4 CYLINDER (Cont.)

### ENGINE OILING (Cont.)

2) Unscrew union and remove spring and plunger from pump body. Remove pick-up tube and cover from pump body.

3) Measure clearance between outer rotor-to-pump body, rotor-to-rotor and rotor face-to-pump body flange (see specifications).

4) Using suitable puller, remove drive flange from rotor shaft. Press drive flange on new rotor shaft to a distance of 1.68" (42.7 mm) between flange and rotor face (see illustration).

5) To install, reverse removal procedure, noting the following if replacing a gear-type pump with a rotor-type pump: Install a 46-link drive chain, and adjust chain tension so that chain can be depressed with light thumb pressure. Compensating plates are available for insertion between block and pump mounting if chain tension cannot be correctly set. Change upper section of oil filter mounting as rotor-type pump requires larger pressure relief valve opening.

Hummel filters. Replaceable filter has valve incorporated in filter element (see illustration).

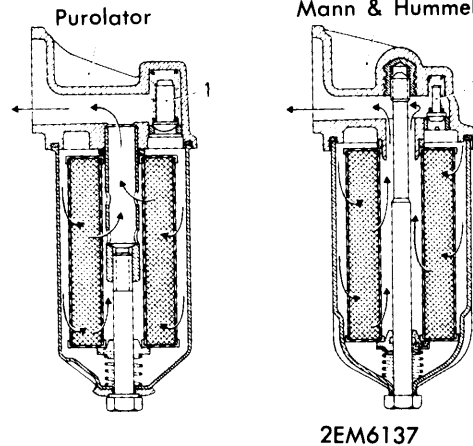

OIL FILTERS

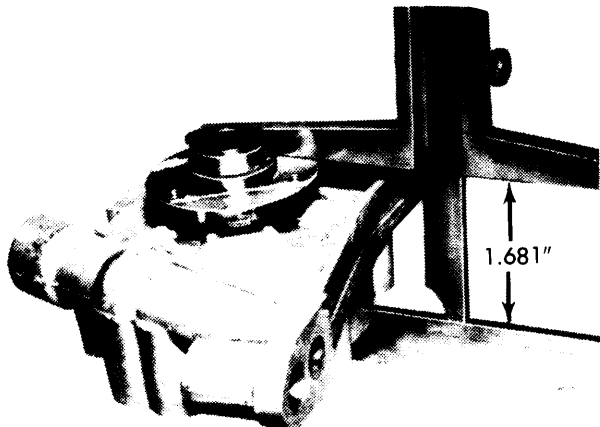

2EM6136

### FAN HUB INSTALLATION MEASUREMENT

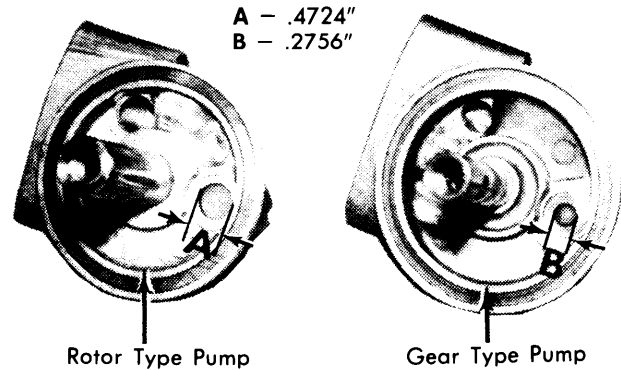

A - .4724"  
B - .2756"

Rotor Type Pump

Gear Type Pump

2EM6138

### OIL FILTER MOUNTS (SHOWING PRESSURE VALVE HOLES)

**NOTE** - When installing compensating plate between oil pump and crankcase make sure oil hole is in proper position.

### Oil Pump Specifications

Application	Measurement In. (mm)
Rotor-to-Housing .....	.0014-.0043 (.04-.11)
Inner-to-Outer Rotor .....	.0047-.0079 (.12-.20)
Cover-to-Rotor .....	.0039-.0059 (.10-.15)
Press. Relief Spring (Free Length) .....	2.68 (68.1)

### OIL FILTERS

Three types of oil filters are used. They can not be interchanged without changing filter mounts. There is a Purolator, Mann & Hummel and a replaceable element type. Pressure relief valve is located in filter mounting on Purolator and Mann &

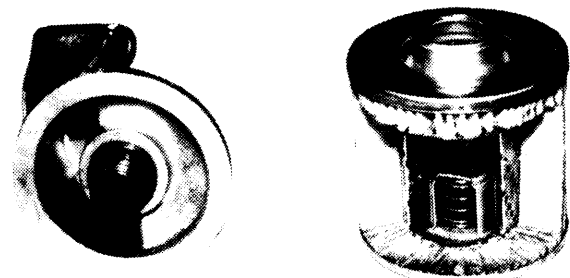

2EM6139

### REPLACEABLE OIL FILTER ELEMENT

## 2002 4 CYLINDER (Cont.)

## ENGINE COOLING

**Thermostat** — Opens at 176°F (80°C).

**Cooling System Capacity** — 7.3 qts. (6.9 liters).

## WATER PUMP

- 1) Loosen alternator bracket. Remove fan and drive belt. Loosen hose clamps and remove water pump.
- 2) Using a suitable puller, remove fan hub from impeller shaft. Extract circlip and spacer ring from front of pump.
- 3) Press impeller off shaft and pump bearing out of housing. Drive friction seal out of housing and lift out cover ring.
- 4) Replace any worn or damaged parts. Using suitable tool, press impeller onto shaft until there is clearance of .031-.047" (.79-1.2 mm) between impeller and pump face (see illustration).

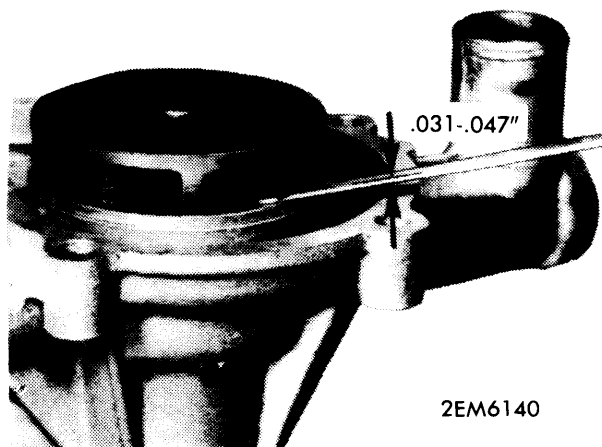

2EM6140

## WATER PUMP IMPELLER INSTALLATION

- 5) Press fan hub onto pump shaft until a distance of 2.957-2.973" (75.1-75.5 mm) exists between hub flange and pump face (see illustration). To install, reverse removal procedure.

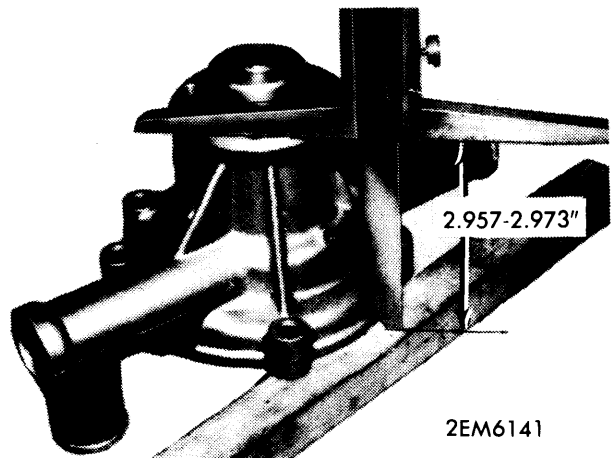

2EM6141

## FAN HUB INSTALLATION

## TIGHTENING SPECIFICATIONS

Application	Ft. Lbs. (mkg)
Cylinder Head Studs ①	
Step 1 .....	24-33 (3.5-4.5)
Step 2 .....	43-47 (6.0-6.5)
Step 3 .....	49-52 (6.8-7.2)
Main Bearing Caps .....	42-46 (5.8-6.3)
Connecting Rod Bolts .....	37-41 (5.2-5.7)
Flywheel-to-Crankshaft ② .....	76-83 (10.5-11.5)
Rocker Arm Lock Bolts .....	7-8 (0.9-1.1)
Oil Pan Bolts .....	7-8 (0.9-1.1)
Camshaft Oiler (Hollow Bolt) .....	8-9 (1.1-1.3)
Crankshaft Pulley .....	101-108 (14-15)
Fuel Pump .....	7-10 (1.0-1.4)
Timing Cover .....	7-18 (0.9-2.5)

① — With engine at normal operating temperature.

② — Coat bolts with Loctite.