

Audi Engines

100LS 4 CYLINDER

| GENERAL SPECIFICATIONS | | | | | | | | | | |
|------------------------|----------|------|------------|-----------|--------------------------|--------------|------|----|--------|------|
| Year | Displ. | | Carburetor | HP at RPM | Torque (Ft. Lbs. at RPM) | Compr. Ratio | Bore | | Stroke | |
| | cu. ins. | cc | | | | | in. | mm | in. | mm |
| 1974 | 114.35 | 1874 | 2-Bbl. | 91@5200 | 110@3500 | 8.2-1 | 3.31 | 84 | 3.32 | 84.4 |

ENGINE IDENTIFICATION

Engine number is die stamped on left side of engine block at clutch housing. Engine number is preceded by two letters which identify year model and transmission type.

Application

Engine Code

Man. Trans. ①
Auto. Trans. ①

① — Information not available at time of publication.

ENGINE REMOVAL

NOTE — The following procedure is engine and transmission assembly removal, as this is the only possible method of engine removal. Also, a hoist, with block-and-tackle and a pit, or suitable frame-contact hoist is necessary for this removal operation.

1) Remove engine hood (only if working with block-and-tackle equipment). Remove apron below front bumper. Disconnect battery. Detach breather hose at air cleaner, remove air cleaner assembly, and cover carburetor opening.

2) Set heater controls at "WARM", remove radiator cap, unscrew plug at bottom of radiator, and drain coolant. **NOTE** — To ensure complete draining of coolant, remove breather screw located in heater inlet hose at firewall. Disconnect all coolant lines between radiator, heater, and engine.

3) Detach fuel hose from fuel pump. Disconnect servo brake unit vacuum hose (if equipped) from intake manifold. Unscrew speedometer cable from transmission. Disconnect clutch cable at mount, and gearshift mechanism connections at transmission.

4) Detach accelerator linkage at carburetor, at mount, and at connecting rod. Remove throttle shaft. Separate brake line at retaining clip on body. To prevent fluid from escaping, brace or otherwise support brake pedal in full up position.

5) Remove guard plate for right engine mount. Disconnect all electrical wiring from engine and transmission, including the following: ignition leads, idle cutoff valve (if installed), thermostat, four-pole plug of regulator, oil pressure switch, starter connections, back-up light switch, and all ground leads.

6) Remove the radiator. Unscrew fan support and remove fan and stop pad (on front crossmember). **NOTE** — This operation is only necessary if a frame contact type hoist or a pit is being used of which the opening is not large enough to permit lowering the engine and transmission with the fan attached.

7) Loosen and remove front exhaust pipe at exhaust manifold and primary muffler. Unscrew driveshaft flange at brake discs (note presence of thin insulator between flange and disc). Turn driveshaft flange in direction of wheel slightly, then fasten driveshafts to upper control arms with wire. Remove front stabilizer bar.

8) Position block and tackle or frame-contact equipment to engine and lift the assembly until pressure is released from engine and transmission mounts. Remove rear crossmember. Unscrew retaining nut from right engine mount (when engine is lowered note location of washers and sleeve on right mount).

9) Unscrew retaining nut of left mount without disturbing position of counter nut on upper side of frame bracket. Carefully lower engine and transmission assembly from vehicle.

10) To install assembly, reverse removal procedure, noting the following: Engine mounts are not to be fully tightened until rear crossmember has been installed and engine alignment and height have been set such that the fan stop may be tightened to its mounting holes without strain.

NOTE — If alternator is replaced on removed engine, ensure mounting nut faces forward. If nut faces starter, alternator removal will not be possible with engine in vehicle.

EXHAUST MANIFOLD REMOVAL

1) With exhaust pipe and air cleaner removed from manifold, unbolt exhaust manifold heat shroud.

2) Unscrew eight mounting nuts and remove exhaust manifold.

NOTE — When installing, ensure notches in gaskets face downward and beaded edge toward outside.

INTAKE MANIFOLD REMOVAL

1) After loosening hose clamps remove coolant hose from between thermostat and intake manifold.

2) Pull vacuum hose off carburetor fitting. Disconnect fuel pump-to-carburetor fuel line at pump. Disconnect air breather hose from manifold. From underside of manifold, remove manifold support bolt.

3) Unbolt and remove intake manifold.

CYLINDER HEAD REMOVAL

1) Remove alternator and bracket, distributor cap, and spark plug wires.

100LS 4 CYLINDER (Cont.)

- 2) Remove cylinder head cover.
- 3) Unscrew oil filter and oil pressure switch. Remove both manifolds as previously described. Detach thermostat housing.
- 4) Remove breather line from water pump and head by unbolting flange on head and metal coupler on pump.
- 5) Detach water pump, fuel pump, and distributor.
- 6) Loosen all rocker arm nuts until arms move freely. Unscrew cylinder head mounting bolts in sequence shown in illustration. Remove cylinder head.

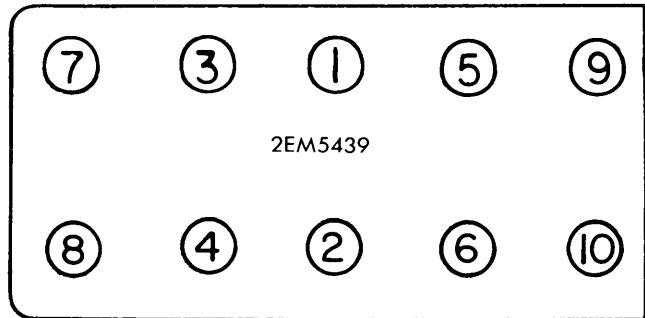

← FRONT
HEAD TIGHTENING SEQUENCE

| VALVES | | | | | | | |
|----------------|---------------------|------------|------------|------------------------|------------------------|-------------------------|---------------------|
| Engine & Valve | Head Diam. In. (mm) | Face Angle | Seat Angle | Seat Width In. (mm) | Stem Diameter In. (mm) | Stem Clearance In. (mm) | Valve Lift In. (mm) |
| 100LS Intake | 1.496 (37.9) | 45° | 45° | .087-.118 (2.2-3.0) | .3532 (8.97) | .0012 (.03) | |
| Exhaust | 1.299 (32.9) | 45° | 45° | .087-.118 (2.2-3.0) | .3524 (8.95) | .0020 (.05) | |

VALVE ARRANGEMENT

I-E-I-E-I-E-I-E (front to rear).

VALVE GUIDE SERVICING

- 1) Heat cylinder head in oil bath or oven to approximately 248°F (120°C). Using a suitable tool, drive valve guide(s) out, working from underside of head.
- 2) Allow head to cool, slowly, to room temperature. Check head bore, using a suitable internal measuring device. Interference fit of new guide must be .0003-.0004" (.007-.010 mm). Select suitable replacement guide(s) and insert lock clip in groove of new guide(s).
- 3) Apply small amount of grease to bore in cylinder, then reheat head to 248°F (120°C). Using valve guide driver (having first undercooled guide, if possible), drive new guide into head until its lock washer is well seated.
- 4) After head has cooled to room temperature, check fit of guide(s) by lightly striking with hammer and drift. Ream guide to correct clearance.

VALVE STEM OIL SEALS

After removing rocker arm assemblies, as previously described, valve stem seals may be pried off, using two screwdrivers. Then, remove intake valve spring discs and exhaust valve spring Rotocaps. Ensure all parts are kept in proper order for reassembly.

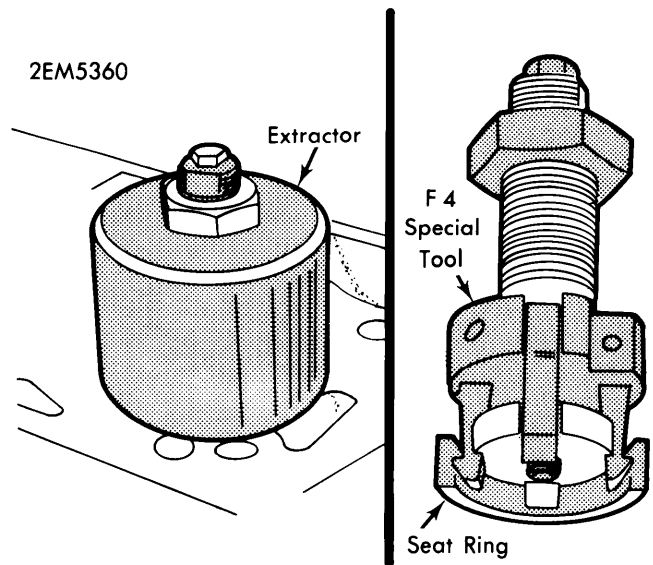

SEAT REMOVAL TOOL

VALVE SEAT INSERTS

- 1) Set up special seat turning tool (F 4, or equivalent), as shown in illustration. Place tool vertically and position cutter on center of cylindrical side of seat insert.
- 2) Attach suitable crank; turn cutter until groove is cut large enough to take up claws of extractor, as in illustration.

100LS 4 CYLINDER (Cont.)

3) Heat cylinder head in oil bath or oven to approximately 248°F (120°C). Remove nut from cutter, then turn hex head of tool screw until claws are firmly in place. Position extractor portion of tool as shown; replace and turn nut until seat is extracted. **NOTE** — *It will be necessary to counterhold head of screw while turning nut.*

4) When selecting replacement seat inserts, note that intake inserts have an inside diameter of 1.3" (33 mm) and a 15° chamfer. Exhaust valve seat inserts have no chamfer and an inside diameter of 1.18" (30 mm).

5) Reheat cylinder head to temperature specified, chill insert, and drive into head (up to stops).

ROCKER ARM ASSEMBLY

Unscrew adjusting nuts and remove rocker arms with rocker balls. Mount suitable valve spring tool to appropriate rocker

arm mounting screw and depress valve springs. Remove valve spring retainers and release springs. Remove outer and inner springs, placing them in order for reassembly (keep all rocker arms, balls, and retainers with their respective springs).

VALVE CLEARANCE ADJUSTMENT

1) Allow engine to reach normal operating temperature. Remove air cleaner, cylinder head cover, spark plugs, and distributor cap, as necessary.

2) Jack up one front wheel and place transmission in 4th gear. Turn raised wheel until No. 1 piston is at TDC of compression stroke, with valves of No. 4 cylinder overlapped. Both valves of No. 1 cylinder should be closed.

3) Adjust valves in firing order: 1-3-4-2. Turn adjusting nut on each rocker arm until appropriate clearance is reached:

Intake..... .004" (.10 mm)..... .008" (.20 mm)
Exhaust..... .014" (.35 mm)..... .016" (.40 mm)

| PISTONS, PINS, RINGS | | | | | | |
|----------------------|-----------------------|----------------------------|---------------------|-------|---------------------|----------------------------|
| Engine | PISTONS | PINS | | RINGS | | |
| | Clearance In. (mm) | Piston Fit In. (mm) | Rod Fit In. (mm) | Rings | End Gap In. (mm) | Side Clearance In. (mm) |
| 100LS | .012 (.3) | .0005-.0009 (.013-.023) | Press Fit | All | .039 (1.0) | .006 (.15) |

PISTON & ROD ASSEMBLY

1) Remove oil pan. Counterhold crankshaft (at flywheel) and remove crankshaft pulley retaining nut. Detach crankshaft pulley.

2) Unscrew retaining bolts from timing cover, remove chain tensioner, and remove guide strip. Remove camshaft gear mounting screw and remove gear together with timing chain.

3) Mark flywheel and crankshaft for reassembly, then unbolt and remove flywheel.

4) If necessary, remove transmission drive shaft guide bearing, using a suitable extractor (M-5).

5) Unbolt both flange couplings and remove oil tube. Remove oil pump retaining screw and pull pump out of block.

6) Unscrew connecting rod bearing caps and set aside, in exact order, for reinstallation. Push the rod and piston assemblies out toward cylinder head side, keeping assemblies in exact order for reinstallation.

PISTON PIN REPLACEMENT

1) Remove circlip. Heat piston and pin assembly to approximately 140°F (60°C). Using suitable driver, remove pin from piston and rod.

2) Measure pin diameter and rod bushing wear. If measurements exceed specifications, replace components.

3) Replace pin using same procedure as for removal. Lock pin in place with snap ring.

FITTING PISTONS

NOTE — *Cylinder sizes of new, as well as exchange, engines are die stamped on starter end of block just below cylinder head.*

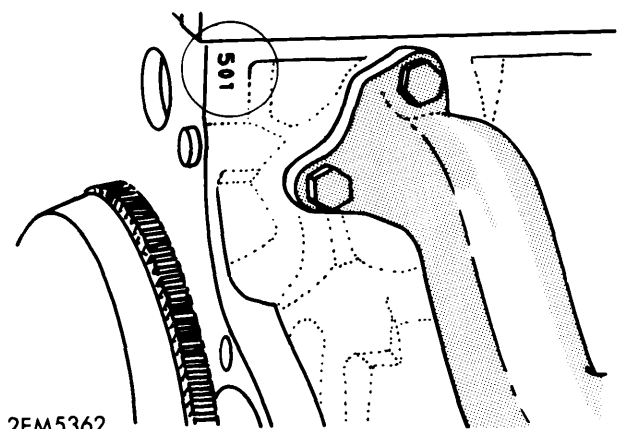

CYLINDER CODE MARK

1) Measure cylinder bores at three levels (top, middle, and bottom), then repeat procedure 90° to first measurements. If amount of wear is greater than .00315" (.08 mm) from specifications listed in table, rebore cylinder and install over-size pistons.

100LS 4 CYLINDER (Cont.)

Standard Pistons & Cylinder Diameter

| Piston Dia. ① | Cyl. Dia. ① | Stamp Code |
|----------------------|---------------------|------------|
| 3.3062 (83.98) | 3.3074 (84.01)..... | 401 |
| 3.3066 (83.99) | 3.3078 (84.02)..... | 402 |
| 3.3070 (84.00) | 3.3082 (84.03)..... | 403 |

Oversize Pistons & Cylinder Diameter

| Piston Dia. ① | Cyl. Dia. ① | Stamp Code |
|----------------------|---------------------|------------|
| 3.3161 (84.23) | 3.3173 (84.26)..... | 426 |
| 3.3165 (84.24) | 3.3177 (84.27)..... | 427 |
| 3.3169 (84.25) | 3.3181 (84.28)..... | 428 |
| 3.3259 (84.48) | 3.3271 (84.51)..... | 451 |
| 3.3263 (84.49) | 3.3275 (84.52)..... | 452 |
| 3.3267 (84.50) | 3.3279 (84.53)..... | 453 |
| 3.3456 (84.98) | 3.3468 (85.01)..... | 501 |
| 3.3460 (84.99) | 3.3472 (85.02)..... | 502 |
| 3.3464 (85.00) | 3.3476 (85.03)..... | 503 |

① — Measurements are In. (mm).

2) If reusing pistons, measure OD approximately 0.63" (16 mm) from bottom of piston and at 90° to pin bore. Piston wear which exceeds .0016" (.04 mm) beyond specification necessitates replacement.

3) Check piston ring side clearance and end gap. Replace rings which exceed specifications. Install rings with side marked "Top" facing up. Space end gaps so that rings are staggered and not parallel with block centerline.

4) Check piston pins as previously described. Check connecting rod bushings. Inside diameter of bushing should be .949" (24 mm) in order to provide proper clearance for piston pin in rod bushing. If replacing connecting rod bushing, new bushing must be a press fit in connecting rod: .0012-.0035" (.029-.09 mm) interference fit.

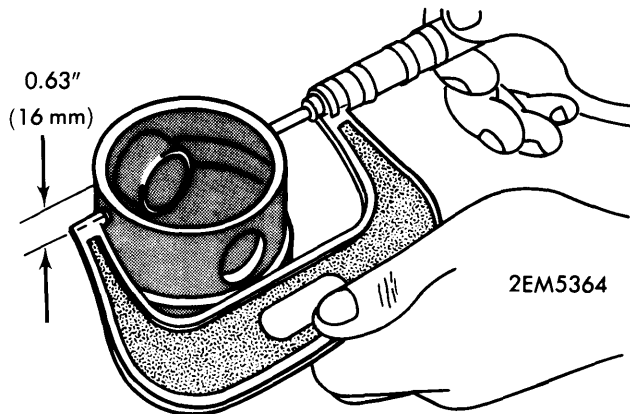

MEASURING PISTON OD

5) Apply thin coat of oil to cylinder surfaces. Slide piston and rod assembly into proper bores (with ring compressor attached), with arrow mark, on top edge of piston, facing forward.

6) Position connecting rod bearings, install new rod cap nuts and bolts and torque to specifications.

CRANKSHAFT MAIN & CONNECTING ROD BEARINGS

| Engine | MAIN BEARINGS | | | | CONNECTING ROD BEARINGS | | |
|--------|------------------------|------------------------|----------------|------------------------------|-------------------------|-----------------------|---------------------|
| | Journal Diam. In. (mm) | Clearance In. (mm) | Thrust Bearing | Crankshaft End Play In. (mm) | Journal Diam. In. (mm) | Clearance In. (mm) | Side Play In. (mm) |
| 100LS | 2.362 (60) | .0016-.0039 (.040-.10) | No. 4 | .0028-.0075 (.07-.19) | 1.889 (47.9) | .0012-.0033 (.03-.08) | .004-.009 (.11-.23) |

CRANKSHAFT REMOVAL

1) Remove oil pan and front pulley. Remove timing cover and camshaft sprocket (with timing chain), see *procedures in Timing Chain Replacement*.

2) Mark relative position of flywheel to crankshaft, then unbolt and remove flywheel. If necessary, use extractor to draw out transmission drive shaft guide bearing.

3) Disconnect oil line at oil pump and block. Unscrew oil pump retaining bolt and pull pump out of block.

4) Unscrew connecting rod bearing caps, remove bearings from rods, and push out piston assemblies. **NOTE** — Keep all parts in proper sequence for reinstallation.

5) Unscrew main bearing cap screws and carefully remove caps with bearings. Lift out crankshaft and extract rear oil seal. Set crankshaft aside, taking care to protect the sealing ring surface.

6) When reinstalling crankshaft gear, heat gear to approximately 140°F (60°C) and slide it onto crankshaft. Fit Woodruff key into position. See *Main Bearing Service* concerning bearing replacement and/or fit.

CAUTION — Number four main bearing cap has a weaker dowel pin boss on one side. If during assembly this boss is broken, entire engine block must be replaced. Main bearing caps are matched to specific block and cannot be interchanged.

MAIN BEARING SERVICE

1) Remove main bearings from block by pressing to one side with fingertips.

2) Clean bearing faces and connecting rod journals. Place Plastigage axially on the journal. Install rod cap in position and tighten bolts to specifications. **NOTE** — Do not turn crankshaft during this operation.

100LS 4 CYLINDER (Cont.)

3) Remove rod cap and measure width of Plastigage with scale provided. Corresponding number on scale represents bearing clearance. Repeat procedure for other connecting rod journals. Replace bearings and rework journals as necessary.

4) Install main bearing caps, with bearings, to block (crankshaft not installed). Tighten cap bolts to specifications. Insert suitable gauge and determine wear on main bearings. Procedure may be repeated for connecting rod bearings.

5) Bearings are available in three undersizes, in increments of .010" (.25 mm).

6) Install crankshaft to block and repeat Plastigage method to determine main bearing clearance. If main bearing replacement is required, replace entire set (five bearings).

ENGINE FRONT COVER & OIL SEAL

If front oil seal leakage is determined, seal may be replaced without removing timing cover, as follows:

- 1) Remove crankshaft pulley. Carefully pry out seal using screwdriver.
- 2) Apply suitable lubricant to lips of new seal and outer edge of seal. Place seal in position with open end facing engine. Using suitable tool (SM-3, or equivalent), press in seal.
- 3) If timing cover is removed, press new seal into position from inside, until seal rests against stop.

REAR MAIN BEARING OIL SEAL SERVICE

- 1) To install rear main bearing oil seal, place seal on suitable seal installer (10.3) and slide it on crankshaft by hand with sealing lip facing crankshaft.
- 2) Insert two flywheel mounting bolts through assembly ring. Tighten bolts until seal reaches stop. Remove assembly ring.

CAMSHAFT REMOVAL

- 1) With crankshaft and piston assemblies removed, as previously described, unscrew oil pressure valve from inside block.
- 2) Unscrew camshaft guide flange mounting screws and remove flange from front of block.
- 3) Screw handle (or other suitable device) into camshaft and remove by carefully pulling upward (block in vertical position).
- 4) When installing new, or exchange, camshaft, apply Molykote to bearing and cam surfaces to improve run-in process.

CAMSHAFT END THRUST

- 1) Install camshaft and sprocket. Tighten stretch screw until sprocket rests against flange of camshaft. Check camshaft for ease of operation.
- 2) Check camshaft end play with a dial indicator. Maximum permissible slop is .004" (.10 mm). If limit is exceeded, install new camshaft flange.

| VALVE TIMING | | | | |
|--------------|-------------|--------------|-------------|--------------|
| Engine | INTAKE | | EXHAUST | |
| | Open (BTDC) | Close (ABDC) | Open (BBDC) | Close (ATDC) |
| 100LS | 5° | 37° | 39° | 3° |

TIMING CHAIN REPLACEMENT

1) Unscrew timing cover mounting bolts and remove cover. Bend open lockplate and unscrew hydraulic chain tensioner plug, insert screwdriver, or similar tool and turn plunger to the left, to prevent plunger from springing out.

2) Unscrew chain tensioner and guide rail. Remove camshaft sprocket together with timing chain.

3) Use replacement chain with straight links (do not use indented links). Place chain on gear with aligning marks in proper position, see *Valve Timing*.

4) Place base plate of tensioner in position and install tensioner, with plunger. Torque holding screws to specifications.

5) Unlock plunger with screwdriver, by turning left. Check to ensure free movement of plunger. Continue turning counterclockwise, as necessary, as spring and automatic adjuster are built into plunger.

6) Screw in plunger plug with lockplate. Torque plug to specification.

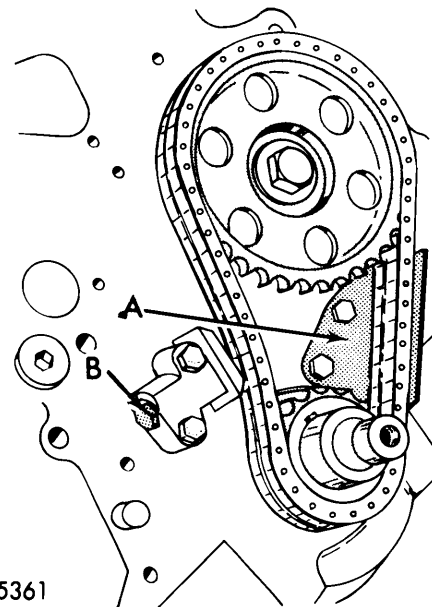

2EM5361

A — Guide Rail

B — Tensioner Plug

TIMING CHAIN ASSEMBLY

100LS 4 CYLINDER (Cont.)

VALVE TIMING

- 1) Remove camshaft sprocket mounting bolt, as it is necessary to remove sprocket when installing chain.
- 2) Turn camshaft sprocket until punched tooth is in exact alignment with notch in guide rail, as illustrated.
- 3) Carefully remove camshaft sprocket; when doing so, do not turn camshaft.
- 4) Turn crankshaft until No. 1 cylinder is at TDC of compression stroke. Place chain over gear and position camshaft sprocket in timing chain such that it is possible to slide sprocket onto camshaft with marks in alignment.
- 5) Torque camshaft sprocket stretch screw to specification.
- 6) Replace chain tensioner, as described previously.
- 7) Recheck No. 1 piston at TDC, of compression stroke, and ensure proper valve overlap on No. 4 cylinder.
- 8) Set valves of No. 1 cylinder **without clearance**, or turn adjusting nut until valves are slightly raised.
- 9) Place dial indicator with slight pretension on intake valve. Set gauge at "ZERO". Continue turning crankshaft clockwise until gauge shows a valve stroke of .040" (1 mm).

10) Timing is correct if timing mark of front pulley shows approximately 6° BTDC. If timing as checked on No. 1 cylinder is within specifications, gap of all valves may be adjusted without checking timing at other cylinders.

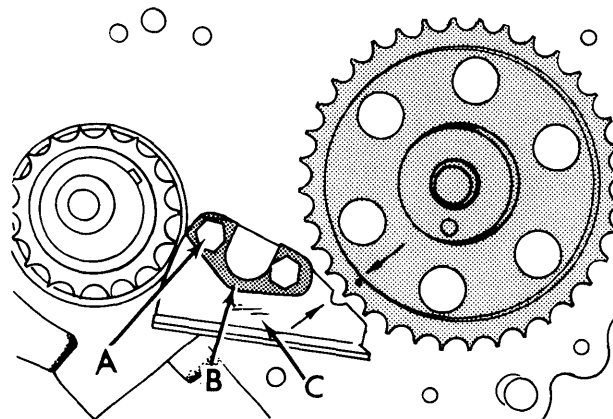

A - Hex Screw

B - Lock Plate

C - Guide Rail

ALIGNING CAMSHAFT SPROCKET

ENGINE OILING

ENGINE OILING SYSTEM

Engine lubrication is accomplished through forced oil circulation. Oil is sucked out of oil pan through pump, fed through a pressure line to oil filter, then into main channels. Rocker lever bearings are lubed from center camshaft bearing, fed through vertical bore in block.

Crankcase Capacity - 4.25 qts. (4 liters).

Oil Filter - Replaceable spin-on type.

Normal Oil Pressure - 14 psi minimum; 85 psi maximum.

WATER PUMP

NOTE - Manufacturer does not recommend overhaul of water pump. If damage or wear is suspected, replace pump.

Remove fan belt(s) and drain coolant. Remove alternator pulley, detach hoses from water pump, and remove thermostat. Unscrew water pump pulley retaining nut while counterholding pulley, then pry pulley off. Unscrew all mounting bolts and remove pump mounting plate and water pump. To install, reverse removal procedure.

Thermostat - 181°F (82°C) summer; 189°F (87°C) winter.

Cooling System Capacity - 8 qts. (7.5 liters).

ENGINE NOTES

After installation of new cylinder head, do not drive vehicle at top speed for approximately 150 miles, to prevent scoring cylinder surface.

TIGHTENING SPECIFICATIONS

| Application | Ft. Lbs. (mkg) |
|---|-----------------|
| Manifolds-to-Head | 17.5 (2.4) |
| Intake Manifold Support..... | 14.5 (2.0) |
| Oil Line (Pump-to-Block)..... | 7 (1.0) |
| Rocker Adjusting Nuts..... | 11-36 (1.5-5.0) |
| Heater Flange-to-Head..... | 14.5 (2.0) |
| Camshaft Guide Flange..... | 18 (2.5) |
| Timing Chain Guide Rail..... | 9 (1.2) |
| Rocker Studs..... | Ⓢ 140 (10) |
| No. 5 Main Bearing Cap..... | 24 (3.2) |
| Other Main Bearing Caps (In Steps)..... | 58 (8.0) |
| Engine Mount-to-Block..... | 30 (4.2) |
| Engine Mount-to-Carrier..... | 43 (6.0) |
| Oil Pump-to-Block..... | 14.5 (2.0) |
| Connecting Rod Caps..... | 25-31 (3.5-4.3) |
| Crankshaft Pulley..... | 130-180 (18-25) |
| Head Bolts (In Steps) | |
| Step 1..... | 29 (4.0) |
| Step 2..... | 43 (6.0) |
| Step 3..... | 58 (8.0) |
| Step 4 (Engine Warm)..... | 65 (9.0) |
| Timing Cover..... | 7 (1.0) |
| Oil Pan | |
| 8mm Bolts..... | 11 (1.5) |
| 6mm Bolts..... | 6 (0.8) |

Ⓢ - Maximum torque.