

1969-73 TOYOTA HI-LUX PICKUP

Hi-Lux (1969-73)

DESCRIPTION

Clutch is a dry, single plate, diaphragm spring type. Clutch is engaged or disengaged by a hydraulic system actuated by clutch pedal. A pre-lubricated clutch released bearing is also employed.

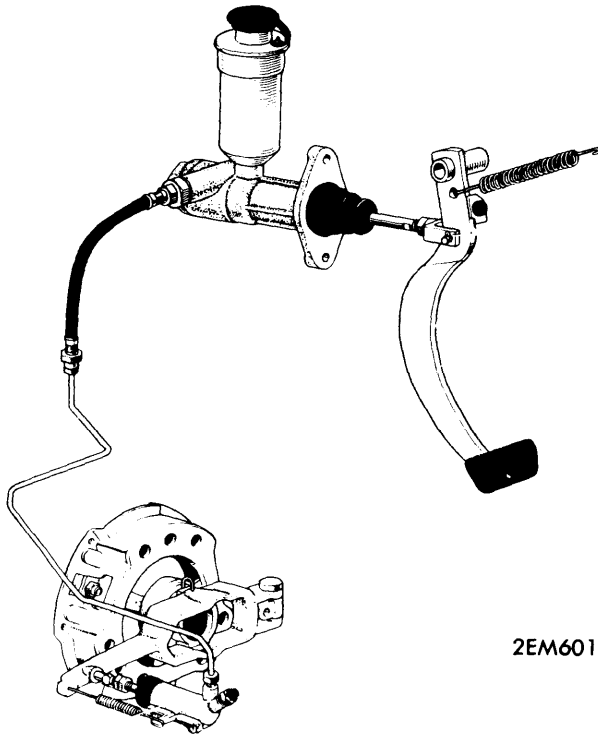

2EM6018

CLUTCH COMPONENTS

REMOVAL & INSTALLATION

CLUTCH ASSEMBLY

- 1) Disconnect positive battery cable, starter bolt and gear shift lever assembly. Disconnect parking brake cable, speedometer cable and back-up light switch.
- 2) Disconnect exhaust pipe support bracket and drain transmission oil. Remove clutch slave cylinder but do not disconnect flex line.
- 3) Remove propeller shaft. Support transmission with suitable jack and remove transmission support crossmember. Lower jack and remove bolts securing clutch housing to engine. Remove transmission toward rear of vehicle.
- 4) Punch locating marks in clutch cover and flywheel for installation. Remove clutch assembly retaining bolts and remove clutch assembly.
- 5) To install, reverse removal procedure. Align punch marks and use a suitable pilot shaft (09301-36010) to align clutch disc. Tighten clutch bolts to specification.

CLUTCH MASTER CYLINDER

- 1) Disconnect flex line at master cylinder and push rod at pedal. Remove master cylinder retaining bolts and remove master cylinder.

- 2) When removing master cylinder, care should be taken not to spill brake fluid on painted surfaces. To install master cylinder, reverse removal procedure.

- 3) With master cylinder installed, adjust pedal height and free play. See *appropriate story in Adjustment Section*. Bleed hydraulic system. See *Hydraulic System Bleeding*.

CLUTCH SLAVE CYLINDER

- 1) Make sure master cylinder reservoir cap is closed and disconnect flex line at slave cylinder. Disconnect clutch fork return spring and remove slave cylinder.

- 2) To install, reverse removal procedure. Adjust clutch fork free play. See *Clutch Fork Free play*. Bleed hydraulic system. See *Hydraulic System Bleeding*.

CLUTCH RELEASE BEARING

- 1) With transmission removed, pull clutch release bearing retaining clips from bearing and fork. Remove bearing with hub.

- 2) Rotate bearing and check for roughness or noise. If bearing is found defective, press old bearing off of hub and press new one on.

- 3) Apply grease to contact points of clutch release bearing and clutch fork.

PILOT BEARING

- 1) With transmission and clutch assembly removed as previously outlined, rotate pilot bearing and check for roughness or noise.

- 2) If bearing is defective, pull from crankshaft with a suitable puller (09303-35010). Apply grease to new bearing and drive in crankshaft with a suitable driver (09304-30012).

OVERHAUL

CLUTCH MASTER CYLINDER

- 1) Remove master cylinder as previously outlined. Remove reservoir cap, float, reservoir retaining nut and reservoir. Pull boot back and remove snap ring.

- 2) Remove push rod, boot and all components from within cylinder bore. Thoroughly clean and inspect all components. Measure clearance of piston in cylinder bore.

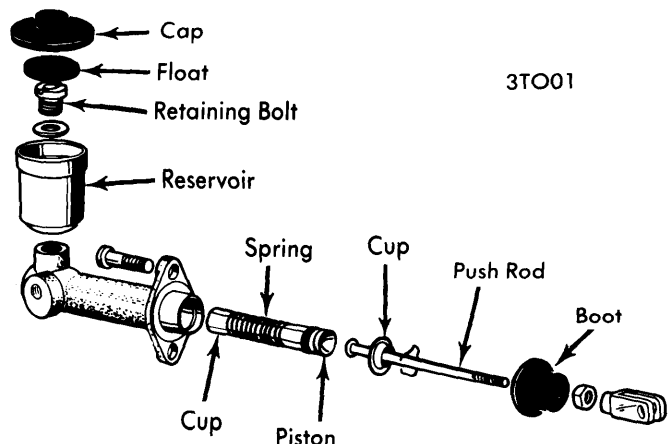

3TO01

CLUTCH MASTER CYLINDER COMPONENTS

- 3) If clearance exceeds .006" (.15 mm), replace piston or cylinder. Check piston and cylinder bore for wear or signs of scoring. Measure return spring free length.

1969-73 TOYOTA HI-LUX PICKUP (Cont.)

4) If free length is less than 3.35" (85mm), replace return spring. Check all cups for wear or damage. Check base of reservoir for damage.

5) Soak all components in clean brake fluid before assembling. Reverse disassembly procedure to assemble.

CLUTCH SLAVE CYLINDER

1) Remove clutch slave cylinder as previously outlined. Pull both push rods, boot and piston from cylinder bore. Thoroughly clean and inspect all components.

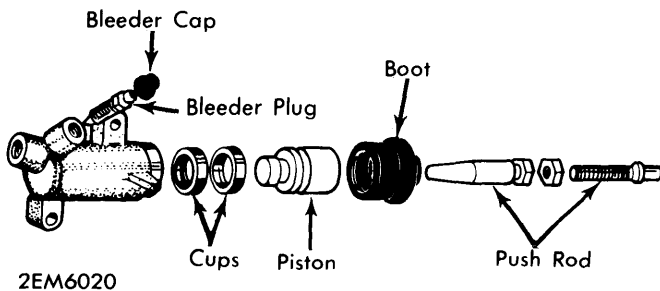

CLUTCH SLAVE CYLINDER

2) Check piston and cylinder bore for wear or signs of scoring. Measure piston-to-cylinder bore clearance, replace piston or cylinder if clearance exceeds .006" (.15 mm).

3) Check cups for wear or damage. Check bleeder plug and plug seat in cylinder for damage. Check clutch fork return spring for wear or cracking.

4) To assemble slave cylinder, reverse disassembly procedure. Soak all components in clean brake fluid before assembling.

ADJUSTMENT

CLUTCH FORK FREE PLAY

Clutch fork free play determines amount of clearance between clutch release bearing and clutch assembly. Adjust slave cylinder push rod until free play at clutch fork is .145" (3.70 mm). See illustration.

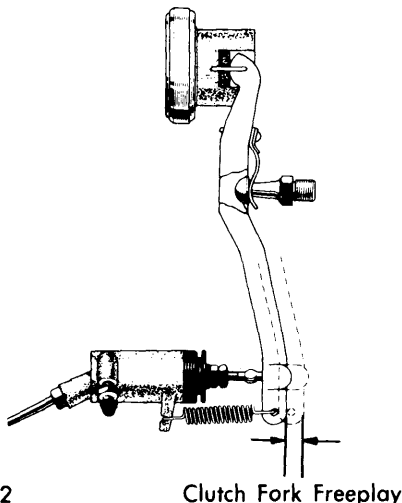

CLUTCH FORK FREE PLAY MEASURING POINT

CLUTCH PEDAL HEIGHT

Clutch pedal height is measured from floor mat to top of pedal pad (see illustration). Adjust pedal stop bolt at top of pedal assembly until pedal height is 6.02-6.30" (153-160 mm).

CLUTCH PEDAL FREE PLAY

Clutch pedal free play is measured from full up position of pedal to point where clutch master cylinder rod contacts piston in cylinder. Adjust master cylinder push rod until pedal free play is 1.30" (33 mm).

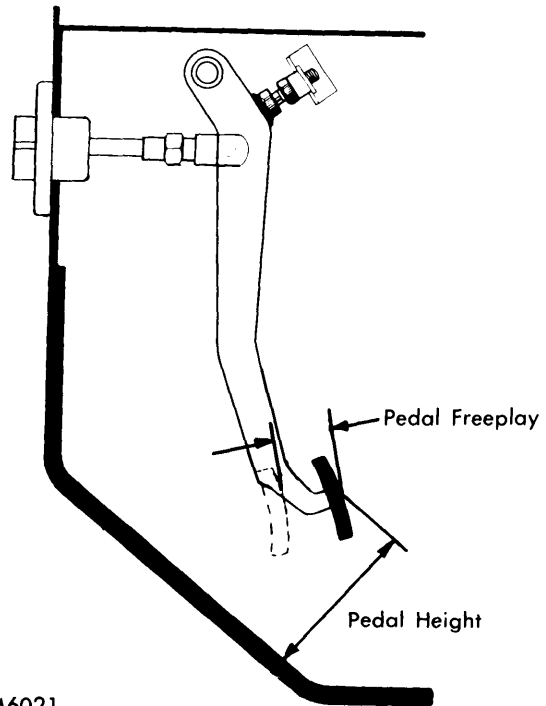

CLUTCH PEDAL HEIGHT & FREE PLAY MEASURING POINTS

CLUTCH MASTER CYLINDER PUSH ROD FREE PLAY

Adjust play between clutch master cylinder push rod and piston by loosening lock nut and rotating push rod until a clearance of .020-.120" (.50-3.0 mm), measured at top of pedal, is obtained.

HYDRAULIC SYSTEM BLEEDING

1) Make sure master cylinder is full of brake fluid. Raise rear of vehicle and support with safety stands. Remove bleeder plug cap and install a flexible line on bleeder plug.

2) Insert opposite end of tube in a container half full of brake fluid. Pump clutch pedal several times and when fully depressed, open bleeder plug one-third to one-half turn.

Clutches

1969-73 TOYOTA HI-LUX PICKUP (Cont.)

3) With plug open, air will bleed out of system into container causing air bubbles in fluid. Repeat procedure until air bubbles are no longer seen in fluid.

4) Tighten bleeder plug and install cap. Recheck fluid level in master cylinder. Check complete hydraulic system for leaks after bleeding procedure is completed.

TIGHTENING SPECIFICATIONS

Application	Ft. Lbs. (mkg)
Master Cylinder Reservoir Bolt	14-22 (1.9-3.0)
Pressure Plate-to-Flywheel	11-16 (1.5-2.2)
Fork Support-to-Trans. Case	14-22 (1.9-3.0)
Clutch Housing-to-Engine.....	36-51 (4.9-7.0)