

1973 AUSTIN MARINA

Marina (1973)

DESCRIPTION

Clutch is dry, single plate, diaphragm spring type design. Clutch release system is self-adjusting and hydraulically actuated.

REMOVAL & INSTALLATION

CLUTCH ASSEMBLY

1) Remove six nuts and washers retaining the two clamp plates, then remove carburetor. From clutch slave cylinder, remove fluid supply hose, then remove screw securing pipe clip to body. Remove shifter assembly from transmission, then disconnect propeller shaft from transmission flange, noting position of all parts for reassembly reference.

2) Remove retaining bolt and clip, then remove speedometer cable. Remove starter attaching bolts, then place starter in engine compartment. Remove clip screw, nut and bolt retaining exhaust pipe support bracket, then support engine and transmission. Remove bolts retaining oil pan connecting plate to transmission, then remove bolts securing rear crossmember to frame.

3) Remove rear crossmember from transmission, then remove bolts, spring washers and nuts securing transmission to mounting plate and engine block. Disconnect ground strap, then lower rear of transmission and engine assembly and remove transmission. Mark clutch and flywheel for reassembly reference, then remove clutch attaching screws and remove clutch assembly.

4) To install, place clutch disc against flywheel with clutch spring housing facing outward, then install a suitable aligning tool (18G 1195) through splines of disc and into pilot in rear of crankshaft. Install pressure plate noting marks made at disassembly, then install transmission, making sure that clutch is not damaged when mounting to engine. To complete assembly, reverse removal procedure.

CLUTCH RELEASE BEARING

Remove transmission, then disconnect operating lever from release bearing and remove bearing. To install, place release bearing over transmission input shaft. Engage pivots of operating lever in slots of bearing collar, and at the same time, engage lever retaining spring clip with fulcrum pin in transmission housing. Press operating lever fully into position. Install transmission, then bleed hydraulic system.

CLUTCH MASTER CYLINDER

From inside vehicle, remove cotter pin from operating rod clevis pin on pedal assembly, remove pin, then remove fork from pedal assembly. Disconnect hydraulic line from cylinder, then remove master cylinder attaching nuts and remove cylinder. To install, reverse removal procedure and bleed hydraulic system.

CLUTCH SLAVE CYLINDER

Disconnect hydraulic line, then turn slave cylinder in mounting on transmission until flat on cylinder shoulder faces clutch housing. Place a suitable spreading tool (18G 1213) on housing, with hole in angle foot of tool located over rivet head of operating lever. Press operating rod into slave cylinder until it clears operating lever, then remove rod. Tighten tool until lever

is moved just enough to allow removal of cylinder, then remove slave cylinder. To install, reverse removal procedure and bleed hydraulic system.

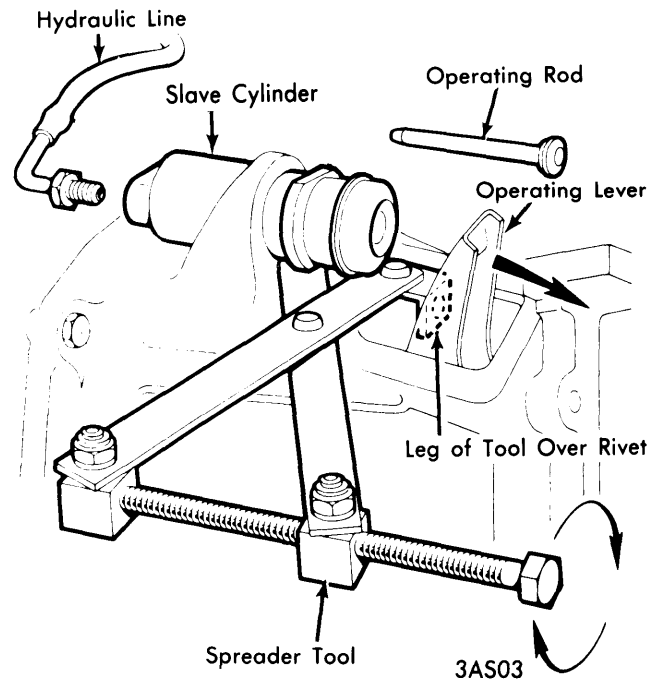

REMOVING SLAVE CYLINDER

OVERHAUL

CLUTCH MASTER CYLINDER

1) Remove dust boot and circlip, then remove push rod assembly. Remove piston and secondary cup seal, piston washer, main cup seal, then remove spring and spring retainer.

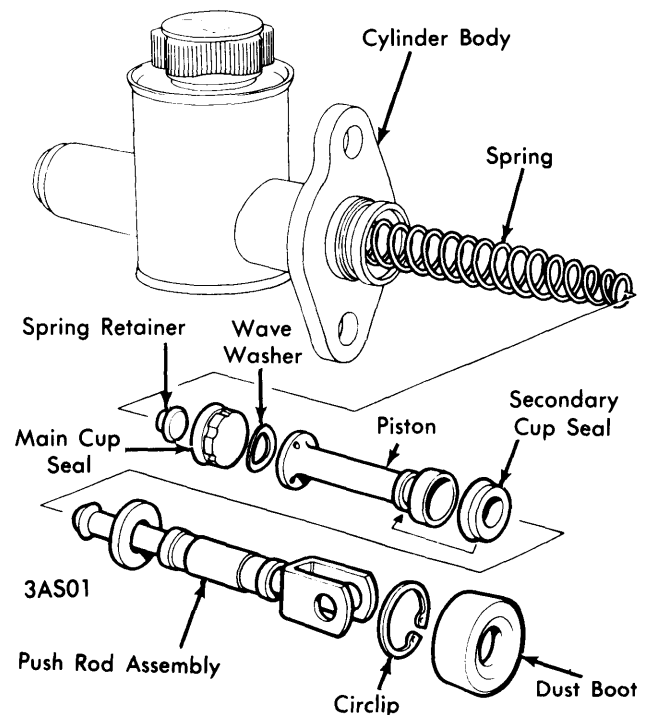

CLUTCH MASTER CYLINDER ASSEMBLY

1973 AUSTIN MARINA (Cont.)

2) Wash master cylinder body in alcohol, internal parts in clean brake fluid, then dry all parts thoroughly. Check bore of cylinder for scores or ridges. Unit must be replaced if damaged. Make sure inlet and outlet ports of master cylinder are free of obstructions.

3) To reassemble, immerse all parts in clean brake fluid. Install secondary cup seal onto piston, then insert spring and retainer into master cylinder bore. Install main cup seal with flat end facing outward, then install wave washer.

4) Install piston into cylinder with small end of piston against wave washer. Coat push rod ball end and shaft with a suitable brake lubricant, install push rod assembly into cylinder, then install circlip. Install master cylinder, then bleed hydraulic system.

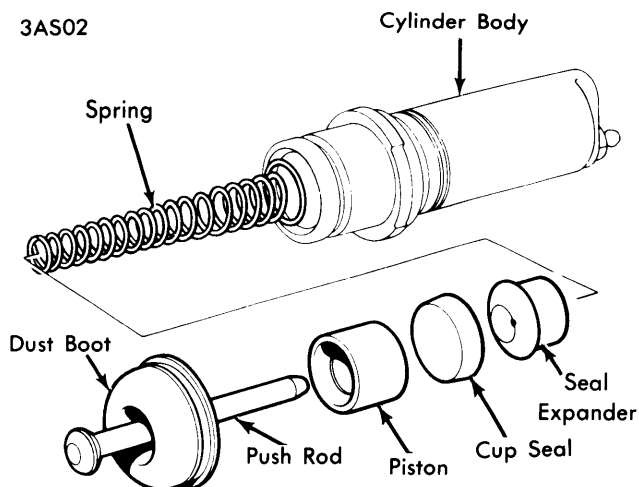

CLUTCH SLAVE CYLINDER ASSEMBLY

ADJUSTMENT

CLUTCH SLAVE CYLINDER

1) Remove cylinder dust cover and push rod, then using air pressure, remove piston and cup seal. If not removed with piston and seal, remove cup seal expander and spring.

2) Wash slave cylinder body in alcohol, internal parts in clean brake fluid, then dry all parts thoroughly. Check cylinder bore for scores or ridges; if not damaged, a new seal may be installed. If damaged, cylinder must be replaced.

3) To reassemble, immerse all parts in clean brake fluid. Install spring into cylinder bore, large end first. Install piston expander, cup seal and piston into cylinder bore. Coat both ends of push rod and bore of dust cover with a suitable brake lubricant, then install into cylinder. Install slave cylinder, then bleed hydraulic system.

HYDRAULIC SYSTEM BLEEDING

1) Make sure master cylinder is full of fluid, and that slave cylinder bleeder screw is at uppermost position. Attach a rubber hose to bleeder screw, then immerse other end of hose in a translucent container of brake fluid.

2) Open bleeder screw approximately $\frac{3}{4}$ turn, depress clutch pedal to end of its travel, then close bleeder screw before allowing pedal to return to normal position. Continue procedure until fluid delivered into container is free of air bubbles. **NOTE** — Make sure that master cylinder fluid level does not fall so low as to allow air to enter system. Refill master cylinder to level mark on reservoir.