

## 1968-69 TRIUMPH TR250 & 1969-73 TR6 6 CYLINDER

GENERAL SPECIFICATIONS										
Year	Displ.		Carburetor	HP at RPM	Torque (Ft. Lbs. at RPM)	Compr. Ratio	Bore		Stroke	
	cu. ins.	cc					in.	mm	in.	mm
1968-71	152	2498	2x1-Bbl.	104@4500	143@3000	8.5-1	2.94	74.7	3.74	95
1972-73	152	2498	2x1-Bbl.	106@4900	133@3000	7.75-1	2.94	74.7	3.74	95

### ENGINE IDENTIFICATION

Engine number is stamped on left side of engine, just below number six spark plug. All engine numbers will contain the prefix "CC" or "CC/CF".

### ENGINE REMOVAL

- 1) Disconnect battery, remove hood, air cleaner and radiator. Disconnect throttle linkage, choke control and all electrical connections from engine.
- 2) Disconnect tachometer drive at distributor and all vacuum lines. Disconnect exhaust pipe at manifold. On TR 6 models, remove "U" bolts securing steering box to chassis.
- 3) From inside drivers compartment on TR250 models, remove gearshift knob, boot, dashboard support and transmission cover.
- 4) From inside drivers compartment on TR 6 models, remove seats, instrument panel support, carpet and transmission tunnel cover. Remove gear shift lever.
- 5) On all models, disconnect driveshaft, speedometer cable, overdrive solenoid connection (if equipped) and exhaust pipe support bracket. Remove transmission top cover with gearshift lever.
- 6) Attach a hoist to engine lifting eyes and disconnect front motor mounts. Place a jack under transmission and remove rear crossmember.
- 7) Raise front of engine and lower transmission until engine and transmission can clear engine compartment. To install, reverse removal procedure.

### INTAKE MANIFOLD REMOVAL

- 1) Disconnect battery, drain cooling system and remove air cleaner. Disconnect throttle linkage, choke controls and fuel lines to carburetors.

- 2) Disconnect vacuum lines, brake servo pipe and water hoses to rear of manifold. Disconnect exhaust pipe at manifold and remove intake and exhaust manifolds.

- 3) To install, reverse removal procedure. Use new gasket and tighten manifold nuts to specifications. *NOTE* - Do not over tighten manifold nuts.

### CYLINDER HEAD REMOVAL

*NOTE* - Cylinder head can be removed with or without intake manifold removed.

- 1) Disconnect battery, drain cooling system and remove air cleaner. Remove fan belt and water pump. Disconnect throttle linkage and choke controls.
- 2) Remove valve cover, rocker arm assembly and push rods. Disconnect intake and exhaust manifolds from cylinder head if cylinder head only is to be removed. If manifolds are to be removed with cylinder head, disconnect exhaust pipe from manifolds.
- 3) Loosen and remove cylinder head bolts in reverse of tightening sequence. Remove cylinder head.
- 4) To install, reverse removal procedure. Clean mating surfaces, use new gasket and tighten bolts to specifications in sequence shown in illustration.

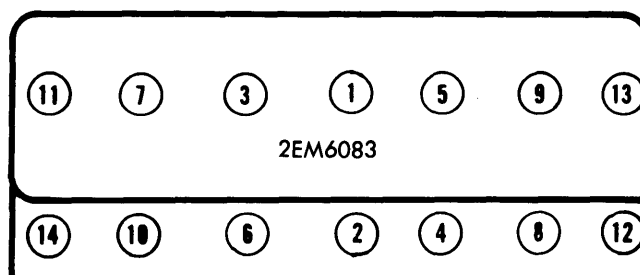

CYLINDER HEAD TIGHTENING SEQUENCE

VALVES							
Engine & Valve	Head Diam. In. (mm)	Face Angle	Seat Angle	Seat Width In. (mm)	Stem Diameter In. (mm)	Stem Clearance In. (mm)	Valve Lift In. (mm)
All Int.	1.441-1.445 (36.6-36.7)	45°	44.5°	.040-.045 (1.02-1.14)	.3107-.3112 (7.874-7.899)	.0008-.0023 (.020-.058)	.....
Exh.	1.256-1.260 (31.9-32.0)	45°	44.5°	.040-.045 (1.02-1.14)	.3101-.3106 (7.87-7.89)	.0015-.0025 (.038-.064)	.....

## 1968-69 TRIUMPH TR250 & 1969-73 TR6 6 CYLINDER (Cont.)

### VALVE ARRANGEMENT

E-I-I-E-E-I-I-E-E-I-I-E (front to rear).

### VALVE GUIDE SERVICING

- 1) With cylinder head removed and disassembled, check rock of valve in guide. If head of valve moves more than .02" across seat, valve guide must be replaced.
- 2) Replace valve guide with a suitable replacing tool (No. 60A). Install guide so that top of guide protrudes .63" from top of head.

### Valve Spring Length

Application	In. (mm)
TR250	
Inner .....	1.56 (39.6)
Outer .....	1.61 (40.9)
TR6	
To Eng. No. CC75000 .....	1.59 (40.4)
From Eng. No. CC75001 .....	1.52 (38.6)
From Eng. No. CF00001	
Inner .....	1.14 (28.96)
Outer .....	1.52 (38.6)

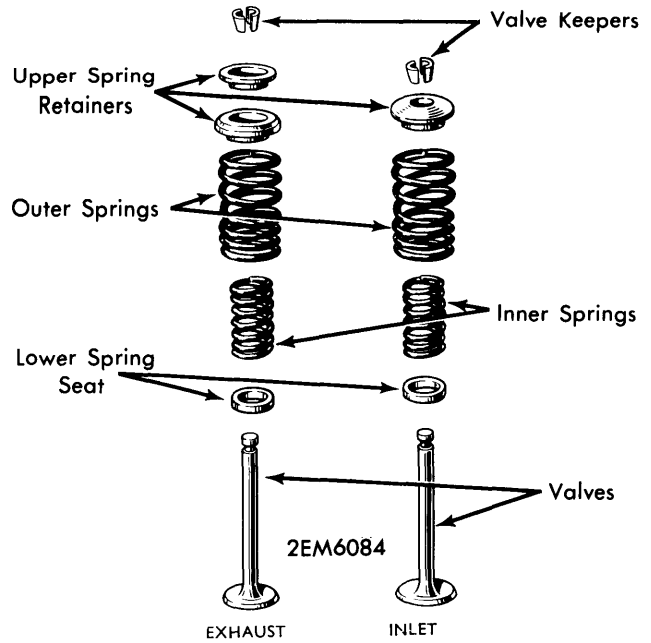

VALVE COMPONENTS

### VALVE SPRING REMOVAL

- 1) With cylinder head removed, compress valve spring with a valve spring compressor. Remove valve keepers and release spring compressor.
- 2) Remove spring retainer, inner (if equipped) and outer spring and lower spring seat. Check springs for wear or cracking. Check springs in a spring tester. If length of spring is less than specified, replace spring.
- 3) To install valve springs, reverse removal procedure. Install components in reverse of removal order.

### ROCKER ARM ASSEMBLY

- 1) With rocker arm assembly removed, remove cotter pin from front of shaft. Slide off front support with rocker arm and double spring washer.
- 2) Remove remaining rockers, springs and support stands. Remove screw securing rear support to shaft. Remove rear support with rocker arm and double spring washer.

- 3) - Thoroughly clean and inspect all components. Clean oil passages in rocker shaft. Measure shaft diameter on rocker arm running surface, if less than .5607", replace shaft.
- 4) Measure bore in rocker arm. If bore exceeds .564", replace rocker arm. If valve contact tip of rocker arm is worn, replace rocker arm, do not reface tip.
- 5) Replace adjusting screws or locknuts if worn or damaged. To assemble rocker assembly, reverse disassembly procedure.

### VALVE TAPPET SERVICE

Inspect face of tappets for wear or chipping. Lubricate tappets before installing. Make sure tappets rotate freely in bore of crankcase.

### VALVE CLEARANCE ADJUSTMENT

Valve clearance is checked or adjusted with engine cold. Rotate engine until piston of valves being adjusted is at TDC of compression stroke. Adjust both intake and exhaust valves to .010".

PISTONS, PINS, RINGS						
Engine	PISTONS	PINS		RINGS		
	Clearance In. (mm)	Piston Fit	Rod Fit	Rings	End Gap In. (mm)	Side Clearance In. (mm)
All	.0020-.0028 (.051-.071)	①	①	1	.012-.017 (.304-.431)	.0015-.0035 (.381-.889)
				2	.008-.013 (.203-.254)	.0015-.0035 (.381-.389)
				3	②	.....

① - Push fit @ 68°F (20°C).  
 ② - Ring ends butt together.

## 1968-69 TRIUMPH TR250 & 1969-73 TR6 6 CYLINDER (Cont.)

### OIL PAN REMOVAL

- 1) Disconnect battery and drain oil pan. Remove dipstick and oil pan retaining bolts. Remove oil pan.
- 2) To install, reverse removal procedure. Clean mating surfaces, use new gasket with sealer and tighten bolts to specifications. Install long bolts in pan reinforcing plate.

### PISTON & ROD ASSEMBLY

- 1) Check rod alignment before installation of piston and rod assembly. Stagger ring gaps on opposite side of thrust side of piston.
- 2) Install piston in cylinder with arrow on top toward front of engine. Install rod cap with numbers on same side as connecting rod. Tighten rod bolts to specifications.

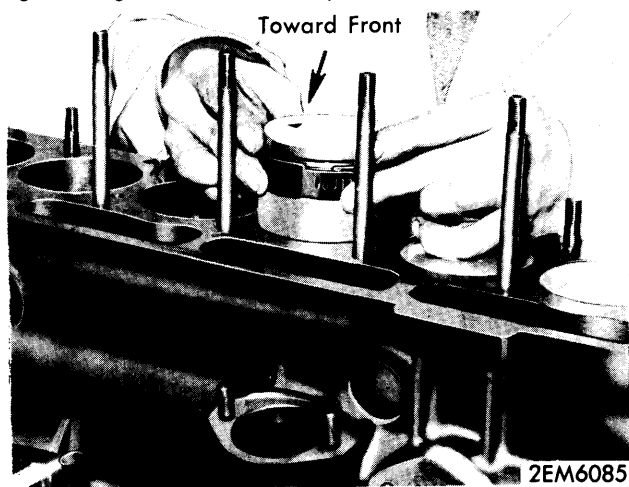

PISTON INSTALLATION

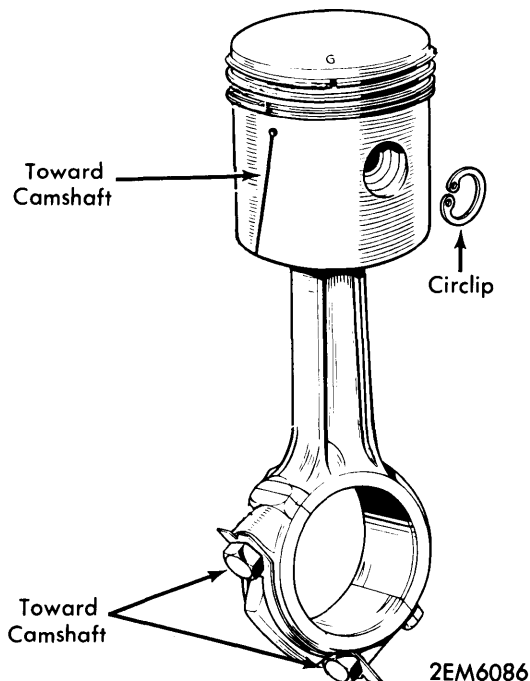

PISTON & ROD ASSEMBLY

### FITTING PISTONS

1) Pistons are manufactured in three classes of size. Size is designated by a letter stamped in top of piston. Cylinders are bored to size according to class of piston. A corresponding letter is stamped next to bore in crankcase.

#### Piston Class Size

Letter Code	Bore Size		Piston Size <sup>①</sup>
	In. (mm)		
Grade A.....	2.9405-2.9410 (74.689-74.701)	..... 2.9380-2.9385 (74.625-74.638)	
Grade B.....	2.9411-2.9416 (74.704-74.717)	..... 2.9386-2.9391 (74.640-74.653)	

① — Measured at bottom of skirt at right angles to pin hole.

### PISTON PIN REPLACEMENT

- 1) With piston and rod removed, remove circlips and drive out piston pin. Piston pin is full floating in piston and connecting rod.
- 2) Pin should push fit through connecting rod with slight thumb pressure at room temperature (68°F). If a dry pin will fall through under its own weight, fit is too loose.
- 3) If pin fit in rod is too loose, bushing must be replaced. Drive out old bushing and install new one, making sure oil holes align with oil holes in rod.
- 4) Position piston on rod so that when arrow on top of piston is facing front of engine, connecting rod bolts are facing camshaft. Install circlip in one side of piston.
- 5) Lubricate and install piston pin until it contacts circlip. Install remaining circlip, making sure both circlips are seated in grooves in piston.

2) If a piston is replaced, one of corresponding class must be installed. Weight of all six pistons must not vary more than seven grams.

3) Measure cylinder bore at different heights in bore. If bore is worn excessively, it must be bored for oversize pistons. Pistons are available .020" oversize.

4) Rings are available .010", .020" and .030" oversize. Check ring gap in cylinder with ring 1/4" from top of bore. Check ring side clearance in piston. Install rings with word "TOP" up.

### CRANKSHAFT MAIN & CONNECTING ROD BEARINGS

Engine	MAIN BEARINGS				CONNECTING ROD BEARINGS		
	Journal Diam. In. (mm)	Clearance In. (mm)	Thrust Bearing	Crankshaft End Play In. (mm)	Journal Diam. In. (mm)	Clearance In. (mm)	Side Play In. (mm)
All	2.311-2.315 (58.70-58.80)	.....	No. 4	.006-.008 (.152-.203)	1.875-1.8755 (47.625-47.638)	.....	.....

# Triumph Engines

## 1968-69 TRIUMPH TR250 & 1969-73 TR6 6 CYLINDER (Cont.)

### MAIN & CONNECTING ROD BEARING SERVICE

1) With crankshaft removed, thoroughly clean and blow out all oil passages with compressed air. Check crankshaft for runout with a dial indicator on center bearing journal. If runout exceeds .002", crankshaft must be straightened.

2) Measure bearing journals for taper or out-of-round. If found excessive, crankshaft must be ground for next oversize bearings. Main bearings are available in .010", .020" and .030" oversize.

3) Rod bearings are available in .010", .020" and .030" oversizes. When installing crankshaft, install caps with numbers matched with numbers stamped in crankcase and facing toward numbers. Tighten main bearing cap bolts to specifications.

### THRUST BEARING ALIGNMENT

Measure end play of crankshaft, if end play exceeds .006", install oversize thrust washers at number four main bearing (rear main bearing). Oversize thrust bearings are available .096" and .098" oversize.

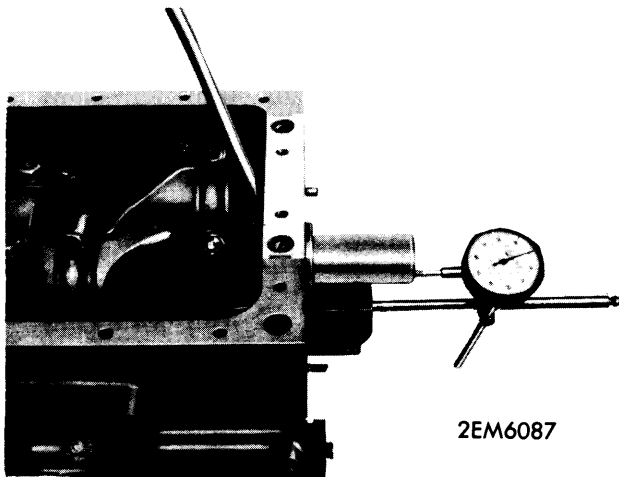

CHECKING CRANKSHAFT END PLAY

### REAR MAIN BEARING OIL SEAL SERVICE

1) Rear main bearing oil seal is secured in mount installed at rear of crankcase. Mount must be removed to replace seal. Remove mount and pry out old seal.

2) Install a new seal in mount and lubricate sealing lip of seal with motor oil. Insert a suitable centering tool (No. S335) in seal.

3) With mating surfaces clean and a new gasket installed, position mount on crankshaft. Tighten bolts to specifications and remove centering tool.

### ENGINE FRONT COVER & OIL SEAL

A new seal should be installed whenever front engine cover is removed. Use new gasket when installing front cover and check timing chain tensioner. Lubricate sealing lip of seal before installing front cover. Lubricate crankshaft sleeve before installation. Tighten bolts to specification.

CAMSHAFT			
Engine	Journal Diam. In. (mm)	Clearance In. (mm)	Lobe Lift In. (mm)
All	1.8402-1.8407 (46.741-46.754)	.0026-.0040 (.066-.102)	.....

### CAMSHAFT REMOVAL

1) Disconnect battery, remove radiator valance, radiator grille and radiator. Remove cylinder head as previously outlined. Remove valve tappets.

2) Bend over lock-tabs and remove camshaft sprocket bolts. Remove sprocket and timing chain. Remove distributor, distributor drive and fuel pump.

3) Remove camshaft lockplate and withdraw camshaft carefully to avoid damaging cam lobes or bearings. To install, reverse removal procedure. Lubricate camshaft before installing and check camshaft endplay. See *Camshaft Endplay*.

### CAMSHAFT ENDPLAY

Check camshaft endplay by measuring float of lockplate. If plate floats more than .0075", replace lockplate.

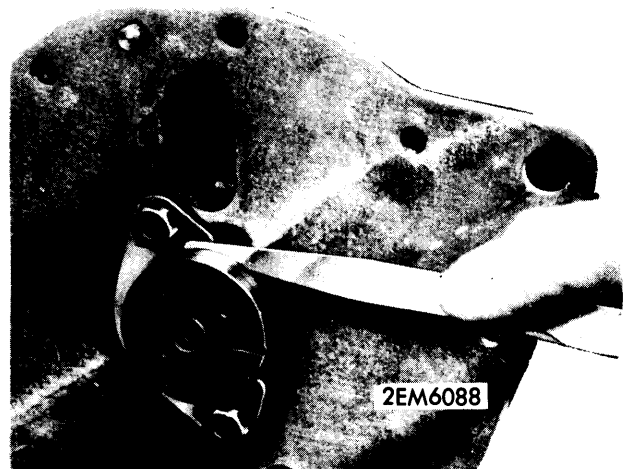

CHECKING CAMSHAFT END PLAY

VALVE TIMING				
Engine	INTAKE		EXHAUST	
	Open (BTDC)	Close (ABDC)	Open (BBDC)	Close (ATDC)
TR250	10°	50°	50°	10°
TR6				
1969-71	10°	50°	50°	10°
1972-73	18°	58°	58°	18°

## 1968-69 TRIUMPH TR250 & 1969-73 TR6 6 CYLINDER (Cont.)

### TIMING CHAIN REPLACEMENT

- 1) Remove front engine cover, and remove camshaft sprocket and timing chain. Check camshaft sprocket and crankshaft sprocket for wear or damage and replace as necessary.
- 2) Install camshaft sprocket on camshaft without timing chain. Place a straight edge across sprockets and check difference in height.

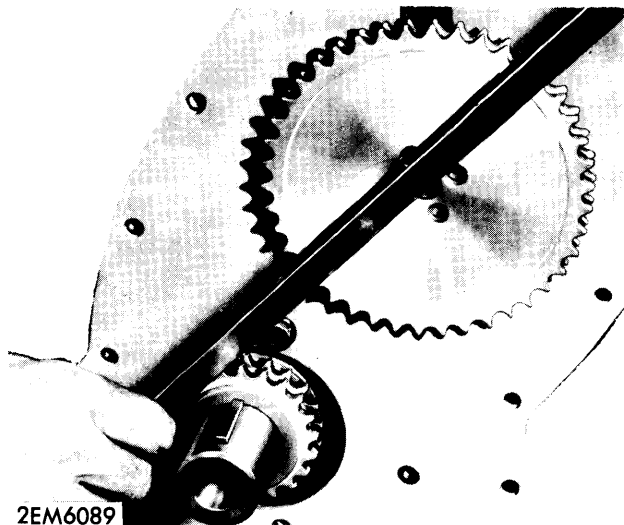

CHECKING SPROCKET HEIGHT

- 3) If height of sprockets varies considerably, remove or install shims behind crankshaft sprocket to obtain a minimum difference in height. Remove camshaft sprocket.
- 4) Position timing chain on sprocket and install sprocket and chain in correct position. See *Valve Timing*. To install remaining components, reverse removal procedure.

### VALVE TIMING

**Unmarked Sprockets TR 6** – 1) With timing chain removed and sprockets installed, rotate flywheel until TDC mark on flywheel is approximately 45° from mark on engine back plate.

2) Adjust valve clearance for valves of cylinders one through five to .010". Rotate camshaft in a clockwise rotation to facilitate adjusting valve clearance.

3) Adjust clearance for valves of number six cylinders to .040". Rotate flywheel until TDC mark aligns with mark on rear engine plate.

4) Rotate camshaft until intake valve of number six cylinder is about to open and exhaust valve is about to close. Check by measuring clearance with equal size feeler gauges.

5) Remove camshaft sprocket and position chain on sprocket. Install sprocket on camshaft and chain on crankshaft sprocket. Do not rotate camshaft or crankshaft during installation.

6) If holes in camshaft sprocket do not align with holes in camshaft, rotate sprocket 90° and use other holes in sprocket. If holes still do not align, rotate sprocket 90° in opposite direction from original position to align holes.

7) With holes aligned, tighten sprocket bolts to specification and bend up lock tabs.

**Unmarked Sprockets TR250** – 1) Rotate crankshaft until number one piston is at TDC. With timing chain removed, rotate camshaft until number one push rod reaches highest point of travel.

2) Adjust valve clearance of number twelve valve to .040". Rotate camshaft until number two push rod reaches highest point of travel. Adjust valve clearance of number eleven valve to .040".

3) Rotate camshaft until intake valve of number six cylinder is about to open and exhaust valve is almost closed. To check, measure clearance with equal size feeler gauges.

4) Remove camshaft sprocket, taking care not to move camshaft. Install timing chain on camshaft sprocket and install on camshaft and crankshaft sprocket.

5) Align holes in camshaft sprocket and camshaft. Do not rotate camshaft to align holes. Reposition chain on camshaft sprocket if holes will not align.

6) If holes still do not align, rotate sprocket 90° and use other two holes. These holes allow a quarter of a tooth adjustment.

7) If camshaft sprocket is rotated 90° in opposite direction, a three quarter tooth adjustment is obtained. Take care not to rotate either camshaft or crankshaft during any of these procedures.

8) With sprockets positioned correctly, install camshaft lockplate and tighten bolts. Tighten sprocket bolts and bend over locktabs.

**Marked Sprockets** – Position chain on camshaft sprocket and install sprocket with mark aligned with mark on crankshaft sprocket as shown in illustration. Install lockplate and tighten bolts.

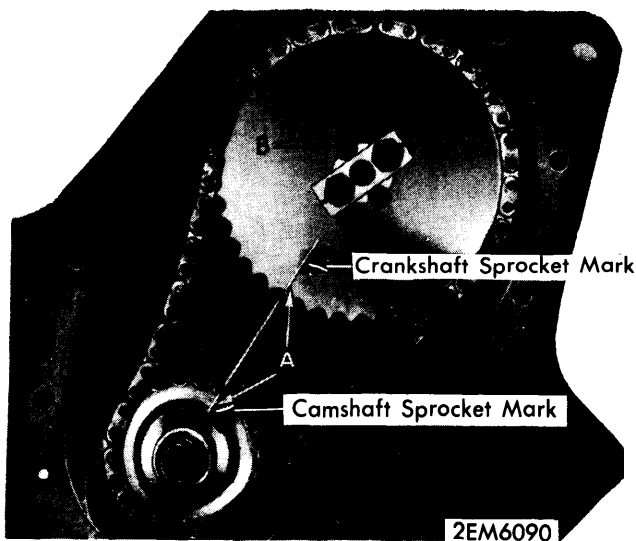

TIMING CHAIN & SPROCKETS INSTALLATION

# Triumph Engines

## 1968-69 TRIUMPH TR250 & 1969-73 TR6 6 CYLINDER (Cont.)

### ENGINE OILING

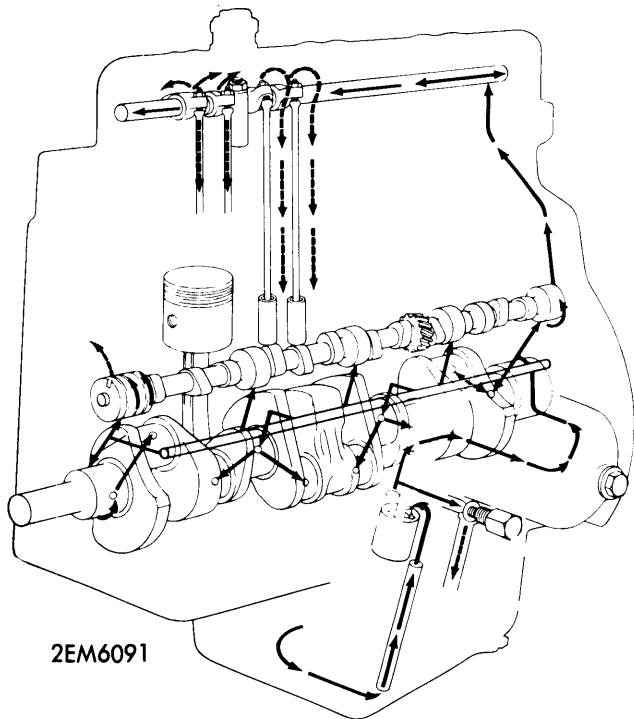

ENGINE OILING DIAGRAM

#### ENGINE OILING SYSTEM

Full pressure oil system, utilizing a rotor type oil pump driven by camshaft. A full-flow oil filter and a pressure regulator valve is also employed.

**Crankcase Capacity** - 4 3/4 qts.

**Oil Filter** - Full-flow, paper element type filter.

**Normal Oil Pressure** - 60 psi @ 2000 RPM.

**Pressure Regulator Valve** - Located in side of crankcase next to oil filter. Remove plug and pull out spring and pison. Check spring free length and for wear or cracking. Lubricate piston and spring when installing. Install plug with new sealing ring.

#### OIL PUMP

1) Remove oil pan as previously outlined. Remove oil pump, separate cover from housing and remove inner and outer rotors.

2) Thoroughly clean and inspect all components. Check clearance between outer rotor and pump housing. Check clearance between inner and outer rotors.

3) Check clearance between rotors and cover using a straight edge on pump housing. If clearances are excessive, replace rotors, housing or cover as necessary.

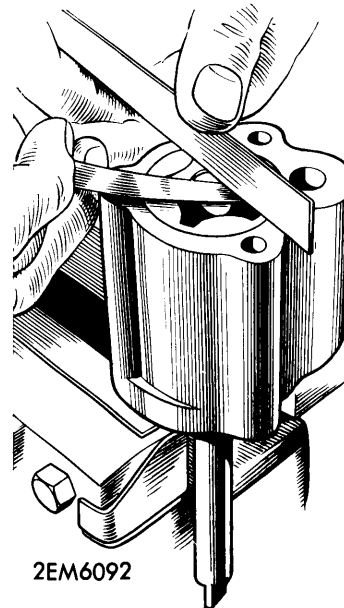

CHECKING ROTOR END PLAY

4) Lubricate all components and assemble pump. Install cover on pump and position pump to crankcase. Evenly tighten bolts and install oil pan as previously outlined.

#### Oil Pump Specifications

Application	Measurement
Rotor-to-Housing Clearance .....	.010" (.254 mm)
Rotor-to-Rotor Clearance .....	.001-.004" (.025-.102 mm)
Rotor Endplay (Rotor-to-Cover) .....	.004" (.102 mm)
Regulator Valve Spring	
Free Length.....	1.53" (40 mm)
Spring Rate .....	53 lb./in. (9466 gm/cm)

### ENGINE COOLING

#### WATER PUMP

1) Disconnect battery and drain cooling system. Disconnect hoses at water pump and temperature sending unit connection. Disconnect fuel and vacuum line clip, and remove water pump.

2) Clean mating surfaces and use new gasket with sealer. To install, reverse removal procedure.

**Thermostat** - Opening temperature fixed by manufacturer.

**Cooling System Capacity** - 6 3/4 qts.

## 1968-69 TRIUMPH TR250 & 1969-73 TR6 6 CYLINDER (Cont.)

### TIGHTENING SPECIFICATIONS

Application	Ft. Lbs. (mkg)
Cylinder Head Nuts .....	60-80 (8.3-11.1)
Connecting Rod Bolts .....	38-46 (5.2-6.4)
Main Bearing Bolts .....	50-65 (6.9-9.0)
Camshaft Sprocket Bolts .....	18-24 (2.5-3.3)
Camshaft Lockplate Bolts .....	16-22 (2.2-3.0)
Front Engine Cover Nuts .....	11-16 (1.5-2.2)
Front Engine Cover Bolts (7/8" long).....	15-20 (2.1-2.8)
Front Engine Cover Bolts (3/8" long).....	7-10 (1.0-1.4)
Front Plate-to-Crankcase .....	16-22 (2.2-3.0)
Manifolds-to-Cylinder Head .....	20-25 (2.8-3.5)
Flywheel Bolts .....	50-75 (6.9-10.4)
Oil Pump Bolts .....	8-10 (1.1-1.4)
Oil Pan Bolts .....	15-20 (2.1-2.8)
Rocker Arm Assembly Nuts .....	24-36 (3.3-3.6)
Rocker Shaft Lockscrew .....	3-5 (.4-.7)
Rocker Cover Nuts .....	1-2 (.1-.3)
Water Pump Bolts .....	15-20 (2.1-2.8)
Rear Main Bearing Oil Seal Mount .....	16-22 (2.2-3.0)
Pressure Regulator Valve Plug .....	25-35 (3.5-4.8)