

Rover Engines

1971-72 LAND ROVER 2.6 LITER 6-CYLINDER

GENERAL SPECIFICATIONS										
Year	Displ.		Carburetor	HP at RPM	Torque (Ft. Lbs. at RPM)	Compr. Ratio	Bore		Stroke	
	cu. ins.	cc					in.	mm	in.	mm
1971-72	160.3	2625	1-Bbl.	95@4500	134@1750	7.8-1	3.063	77.8	3.625	92.07

ENGINE IDENTIFICATION

Engine serial number is stamped on left front of engine.

ENGINE REMOVAL

- 1) Remove hood and disconnect battery ground.
- 2) Drain and remove radiator and grille panel.
- 3) Remove transmission tunnel cover.
- 4) Disconnect header pipe from exhaust manifold, and remove exhaust heat shield.
- 5) Disconnect starter cables at starter, oil pressure lead at switch and engine ground cable at chassis.
- 6) Disconnect heater hoses and heater water valve control cable.
- 7) Disconnect switch lead at ignition coil and fuel line at carburetor.
- 8) Release accelerator return spring and disconnect accelerator linkage at bell crank lever.
- 9) Remove nuts and bolts attaching clutch hydraulic line and speedometer bracket at flywheel housing.
- 10) Disconnect choke cables at carburetor.
- 11) Disconnect servo hose at manifold.
- 12) Disconnect electrical leads at choke and temperature gauges. Disconnect leads at alternator.
- 13) Remove harness clip bolts at engine breather box.
- 14) Remove harness clip nuts at bell housing.
- 15) Support engine with a suitable sling.
- 16) Remove engine front mounts upper and lower nuts.
- 17) Support transmission with a stand or jack. Remove flywheel housing bolts.
- 18) Pull engine forward enough to clear transmission and lift clear of vehicle.

CYLINDER HEAD REMOVAL

- 1) Drain radiator and engine block.
- 2) Disconnect brake servo line from intake manifold.
- 3) Remove carburetor.

- 4) Disconnect accelerator rod and return spring at bell crank lever.
- 5) Disconnect two temperature transmitter leads from head.
- 6) Disconnect rocker oil feed line at rear of cylinder head.
- 7) Remove spark plugs.
- 8) Disconnect radiator top hose and hose from engine breather cap.
- 9) Remove distributor and distributor vacuum line and clip.
- 10) Remove rocker cover.
- 11) Loosen tappet adjusting screws to remove load on rocker arms.
- 12) Remove cylinder head bolts evenly and lift off head.
- 13) Remove "O" ring from by-pass to water pump.
- 14) To reinstall cylinder head, use two old head bolts with their heads cut off and slotted. Screw bolts into block.
- 15) Coat head gasket with oil and position over bolts with marking "THIS SIDE UP" facing up. Replace "O" ring and place cylinder head over bolts.
- 16) Install two head bolts. Remove two bolts with cut off heads. Reverse disassembly procedure.

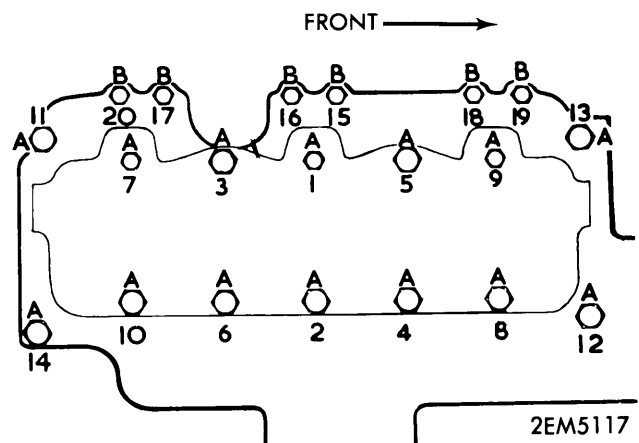

CYLINDER HEAD TIGHTENING SEQUENCE

VALVES							
Engine & Valve	Head Diam.	Face Angle	Seat Angle	Seat Width	Stem Diameter	Stem Clearance	Valve Lift
2.6 Liter							
Int.	1.793-1.797"	30°	30°	-----	.342-.3425"	.0013-.0019"	.374"
Exh.	1.261-1.265"	45°	45°	-----	.341-.3415"	.0023-.0029"	.403"

1971-72 LAND ROVER 2.6 LITER 6-CYLINDER (Cont.)

VALVE ARRANGEMENT

All intake valves are in head and all exhaust valves are in engine block.

VALVE GUIDES

Intake — With head removed and disassembled, drive out valve guides. Using a suitable drift, place guide and spring washer in head and drive in guide. Reface valve seat to 30°.

Exhaust — Remove exhaust manifold and side rocker cover. Remove exhaust valve rocker and shaft. Drive out guides and using a suitable drift, drive in new guides. *NOTE* — Where access is restricted, replacement of valve guides on No. 5 and 6 cylinders may first require engine removal.

VALVE SPRINGS			
Engine	Free Length	PRESSURE (LBS.)	
		Valve Closed	Valve Open
2.6 Liter			
Inner (Int.)	1.703"	21.5@1.437"
Outer (Int.)	1.960"	69.5@1.625"
Inner (Exh.)	1.703"	16.4@1.50"
Outer (Exh.)	1.861"	41.8@1.625"

INTAKE ROCKER ARM ASSEMBLY

Removal — 1) Remove radiator and grille panel.

2) Disconnect high tension leads from spark plugs and remove distributor cap.

3) Disconnect hose at engine breather cap.

4) Remove rocker cover and loosen tappet adjusting screws.

5) Remove nuts, washers and screw retainer plates from rocker spacers.

6) Remove rocker shaft locating screws.

7) Remove end plug and washer from front of cylinder head.

8) Extract front and rear rocker shafts using a suitable tool. Remove rocker arm assemblies and keep in order.

Installation — 1) Insert rear (longer) shaft into head aligning locating holes, with oil holes facing away from valves (See Illustration).

2) Install rocker arm assemblies and push shaft home. Reinstall locating screws and nuts, washers and retainer plates.

3) Repeat procedure for front (shorter) shaft. Adjust tappets and reassemble engine.

VALVE LIFTERS & CAM FOLLOWERS

Located in engine block above camshaft are intake cam followers and exhaust valve rockers. Intake cam followers actuate push rods, which in turn operate rocker arms in cylinder head. Exhaust valve rockers run directly on cam lobes. Rockers

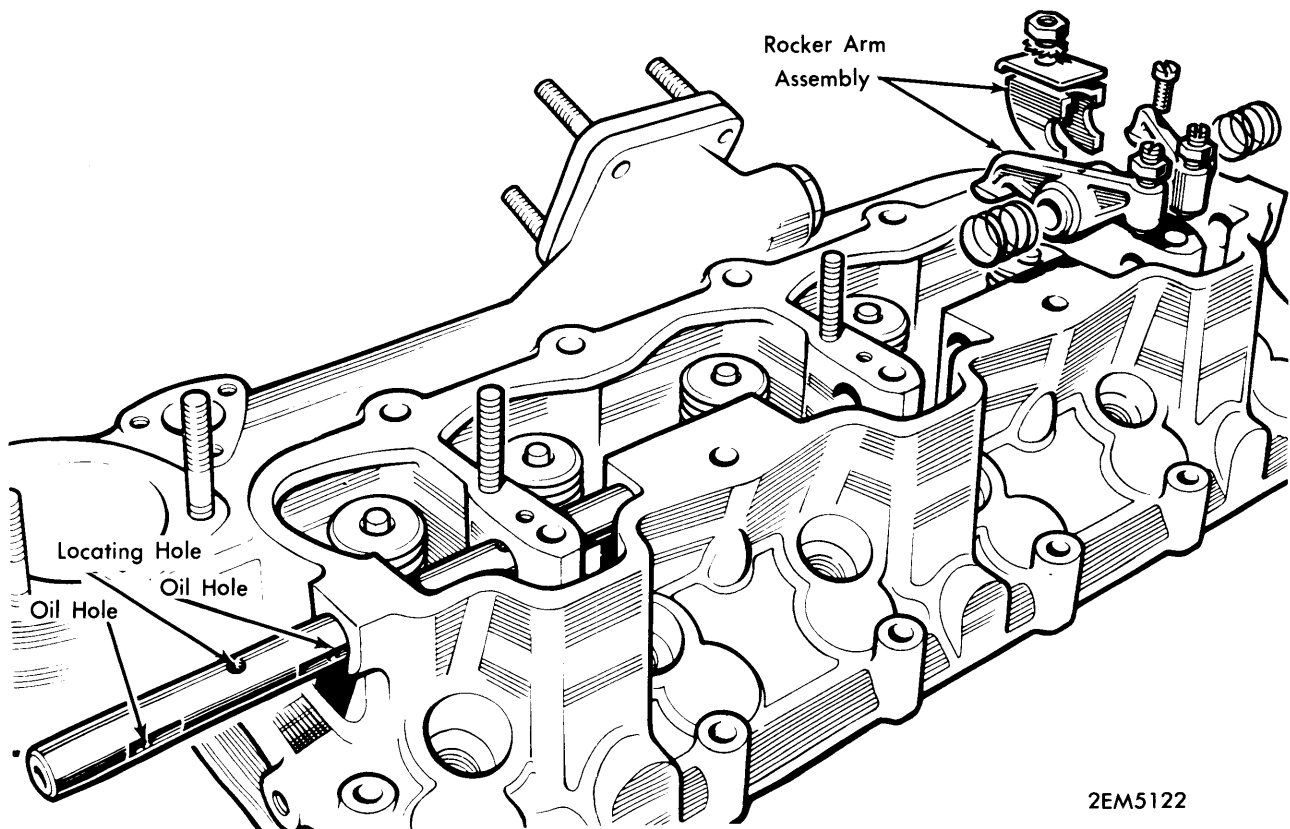

2EM5122

INTAKE ROCKER ARM ASSEMBLY

1971-72 LAND ROVER 2.6 LITER 6-CYLINDER (Cont.)

have exhaust valve tappet screws located in their bodies, and exhaust valve rockers directly operate the exhaust valves, which are located in the engine block.

Removal - 1) Remove radiator, grille panel, exhaust manifold and front timing cover.

2) Remove timing chain tensioner and timing chain with sprockets.

3) Remove top and side rocker covers. Loosen intake and exhaust tappet screws.

4) Remove end plug from front end of rocker shaft. Remove two locating screws and oil feed bolt (See Illustration).

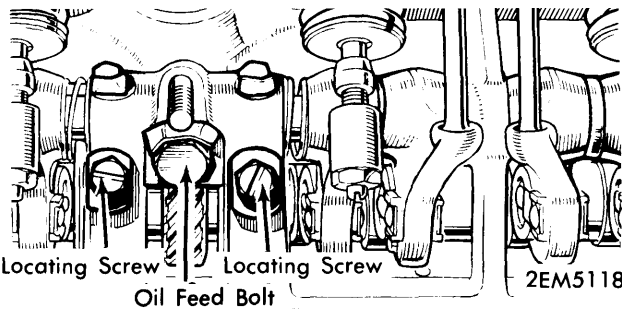

ROCKER ARM & CAM FOLLOWER REMOVAL

5) Using an extractor (Rover Part No. 262749), screw into end of front rocker shaft and withdraw shaft. Lift out rockers, cam followers, springs and spacers. Note sequence for reassembly. Repeat procedure for rear rocker shaft (See Illustration).

Installation - 1) Screw a bolt and washer into end of camshaft. Bolt is used to rotate camshaft lobe to a down position for rocker assembly to be fitted.

2) Replace rear rocker assemblies and use correct washers (See Illustration). Install rocker shaft and new locating screw.

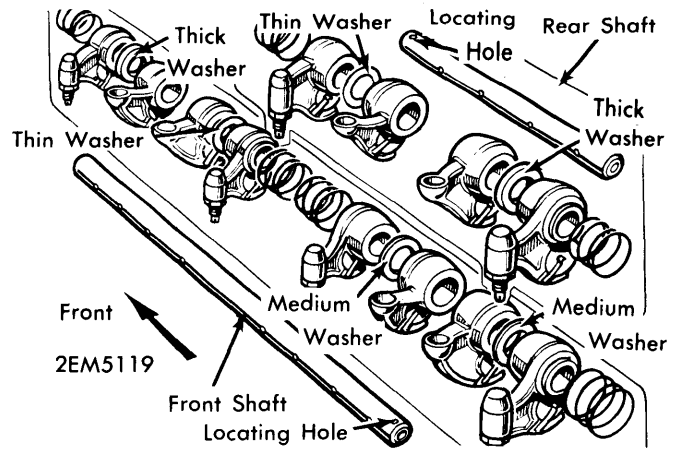

ROCKER & CAM FOLLOWER ASSEMBLY

3) Repeat procedure for front rocker assemblies and shaft.
4) Reverse disassembly procedure for remaining components.

VALVE CLEARANCE ADJUSTMENT

Tappet clearances are intake .006" and exhaust .010". To check clearance of intake and exhaust valves, turn crankshaft until valves in first column are fully open, then valves in second column may be adjusted.

Valves Open	Valves to Adjust
1.....	6
2.....	5
3.....	4
4.....	3
5.....	2
6.....	1

PISTONS, PINS, RINGS						
Engine	PISTONS	PINS		RINGS		
	Clearance	Piston Fit	Rod Fit	Rings	End Gap	Side Clearance
2.6 Liter	.0019-.0024"	⊙	.00095"	Comp. Oil	.015-.020" .015-.033"	.0018-.0038" .002-.004"

⊙ - Push fit by hand.

OIL PAN REMOVAL

- 1) Drain pan and remove dipstick.
- 2) Remove oil pan bolts.
- 3) Lower oil pan to clear oil strainer and withdraw oil pan.
- 4) Using a new pan gasket reverse removal procedure to reinstall.

PISTON & ROD INSTALLATION

Install piston and rod in proper cylinder with oil hole in rod and flat on piston crown facing away from camshaft side of engine (See Illustration). Install rod caps, using new nuts torqued to specifications.

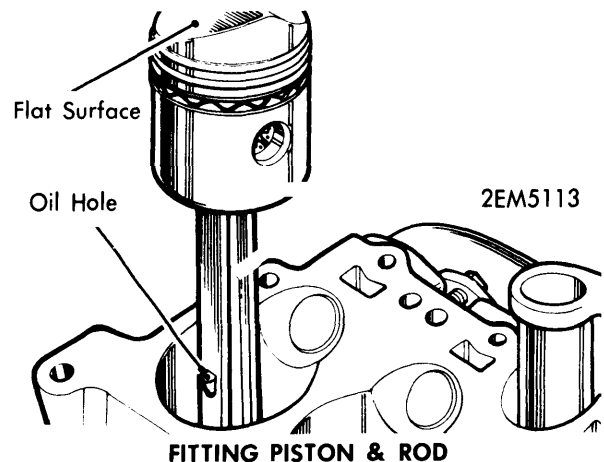

FITTING PISTON & ROD

1971-72 LAND ROVER 2.6 LITER 6-CYLINDER (Cont.)

PISTON PIN REPLACEMENT

Remove circlips from piston and push out piston pin. If rod small end clearance exceeds specifications, replace rod bushing. Press in new bushing, making sure oil holes are aligned. Check piston pin fit in piston. If pin will fall through piston, obtain oversize pin. Correct pin clearance in piston is a push fit by hand. Oversize piston pins are available in .001" and .003" oversizes. After correct pin has been selected, ream connecting rod bushing to specifications.

FITTING PISTONS

When removing pistons mark them so they will be returned to their proper cylinder. Measure piston at bottom of skirt at 90° to piston pin bore. Measure cylinder half way down and determine clearance. Standard size pistons are graded and marked with the letters "Z" nominal to plus .0002", "A" plus .0002-.0004", "B" plus .0004-.0006", "C" plus .0006-.0008" and "D"

plus .0008-.001". Oversize pistons are not graded and are available in .010", .020", .030" and .040" oversizes. Check ring end gap in cylinder, if clearance is insufficient file ends of ring to specifications. Fit rings to piston with compression ring markings "T" or "TOP" facing upward.

When reboring or cylinder sleeve is required, a special jig block (Rover Part No. 261288) will be needed, because cylinder face is inclined at a 22° angle (See Illustration). When a cylinder sleeve is installed an interference fit of .003-.004" is used. A special tool is required, (Rover Part No. 246650), to press in cylinder liner (See Illustration). Allow .187" of unavoidable clockwise rotation when pressing in sleeve. After sleeve has been pressed in cylinder, blend edges to match normal contours. Cylinder sleeves will only accept standard and .010" oversize pistons.

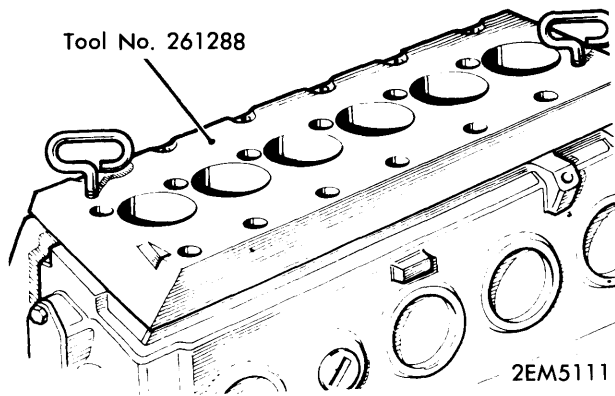

CYLINDER BORING JIG

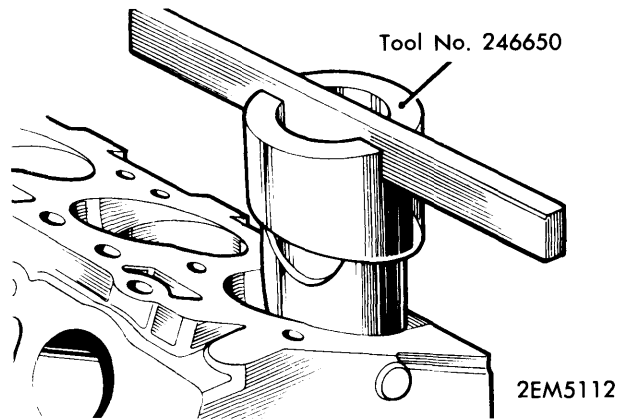

FITTING CYLINDER SLEEVE

CRANKSHAFT MAIN & CONNECTING ROD BEARINGS

Engine	MAIN BEARINGS				CONNECTING ROD BEARINGS		
	Journal Diam.	Clearance	Thrust Bearing	Crankshaft Endplay	Journal Diam.	Clearance	Sideplay
2.6 Liter	2.6245"	.0006-.002"	Rear	.002-.006"	1.875"	.00045-.0017"	.006-.015"

REPLACEMENT BEARINGS

Replacement bearings for both crankshaft main and connecting rod journals are available in .010", .020", .030" and .040" undersizes.

THRUST BEARING ALIGNMENT

Place a standard size thrust washer on each side of rear main bearing with grooves away from block. Using a dial indicator check end-play. Oversize thrust washers are available in .0025", .005", .0075", .010" and .0125" to correct crankshaft end-play. Right and left thrust washers must be within .003" thickness to maintain crankshaft centering.

CONNECTING RODS

1) Check connecting rod alignment. Assemble cap to rod leaving out bearing halves. Torque rod nuts to 20 ft. lbs. Loosen one nut and check joint to see that there is no clearance between joint faces. If clearance exists rod must be replaced.

2) Remove rod cap and place bearings in rod. Fit rod cap and torque rod nuts to 20 ft. lbs. Loosen one nut, using a .002-.004" feeler gauge, insert between rod and cap. The bearing crush may be adjusted by using slightly varying thickness of bearing inserts to achieve proper gap.

3) Using a piece of .00045-.0017" shim paper, make a final check to prove bearing clearance. With a shim paper inserted between rod half and journal, rod should resist rotation. When shim paper is removed, rod should turn freely.

4) Rods may also be checked using the "Plastigauge" method to determine rod clearance.

MAIN BEARINGS

1) Fit main bearing caps, less bearing halves, torque bolts to 75 ft. lbs. Loosen one bolt and check for gap between cap and block. If any gap is present cylinder block must be replaced.

1971-72 LAND ROVER 2.6 LITER 6-CYLINDER (Cont.)

2) Remove main bearing caps, place inserts in block and cap. Torque bolts to 75 ft. lbs. Loosen one bolt and check gap between block and cap. It should be .004-.006". Gap may be adjusted by using slightly varying thickness bearing inserts.

3) Make final check of main bearing clearances by inserting a .0025" shim paper between one half of bearing and crankshaft. Torque cap bolts to specifications. Crankshaft should resist rotation and with shim paper removed should be free to turn. This procedure is done one bearing at a time.

4) Main bearings may also be checked using the "Plastigauge" method to determine clearance.

REAR MAIN BEARING OIL SEAL

Removal - 1) Remove hood, front floor, seat base and transmission. Place a block between flywheel housing and chassis crossmember.

2) Remove starter, oil pan, clutch assembly and flywheel.

3) Attach a lifting sling to engine, apply sufficient tension to support weight of engine.

4) Remove block placed between flywheel housing and crossmember during transmission removal.

5) Remove flywheel housing and oil seal.

6) Remove rear main bearing cap, upper and lower oil seal retainers and rear main bearing oil seal.

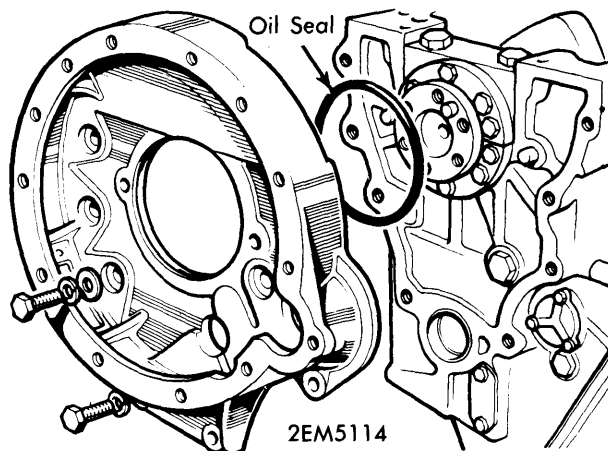
**FLYWHEEL HOUSING SEAL**

Installation - 1) Assemble seal retainer spring on crankshaft by engaging hook and eye. **CAUTION** - Do not stretch spring.

2) Apply silicone grease to oil seal journal and ends of oil seal.

3) Open seal ends just enough to slide over crankshaft. Install seal with spring groove towards flange (See Illustration). Work spring into groove with hook and eye at right angle to oil seal ends.

4) Rotate seal until seal ends are facing toward cylinder head.

5) Apply suitable sealer to seal retainer halves.

6) Attach upper seal retainer half, leaving the two end bolts finger tight.

7) Attach lower seal retainer half to main bearing cap in the same manner as upper retainer half.

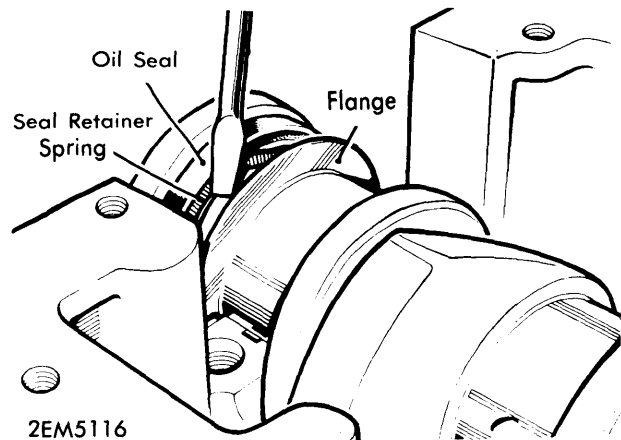
**REAR MAIN BEARING OIL SEAL**

8) Using silicone grease, fit "T" seals to main bearing cap. Trim top edges of "T" seals to prevent them from fouling block when fitted.

9) Fit seal guides to crankcase. Install main bearing cap and "T" seals to crankcase. Leaving .030" clearance between cap and crankcase, check to see that all seals are properly positioned.

10) Torque main bearing cap to 75 ft. lbs. Fully tighten all bolts of seal retainers. **NOTE** - Turn bolt heads so they will clear flywheel housing seal.

11) Trim ends of "T" seals to leave .030" protruding from bearing cap.

ENGINE FRONT COVER & OIL SEAL

Removal - 1) Remove hood, fan belt, radiator and alternator adjusting link.

2) Remove starter dog and crankshaft pulley.

3) Remove front cover bolts and withdraw front cover.

4) Drive out oil seal and coat outside diameter of new seal with suitable sealing compound. Press in new seal.

5) Coat both sides of new gasket with grease. Install gasket and cover in position and replace front cover bolts. **NOTE** - Be sure and install timing pointer bolt in correct location (See Illustration).

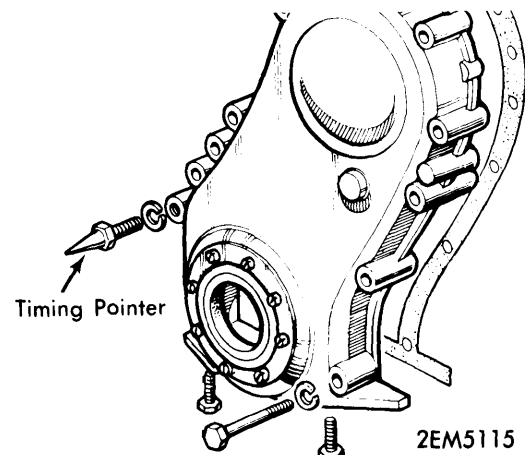
**TIMING COVER**

1971-72 LAND ROVER 2.6 LITER 6-CYLINDER (Cont.)

CAMSHAFT			
Engine	Journal Diam.	Clearance	Lobe Lift
2.6 Liter

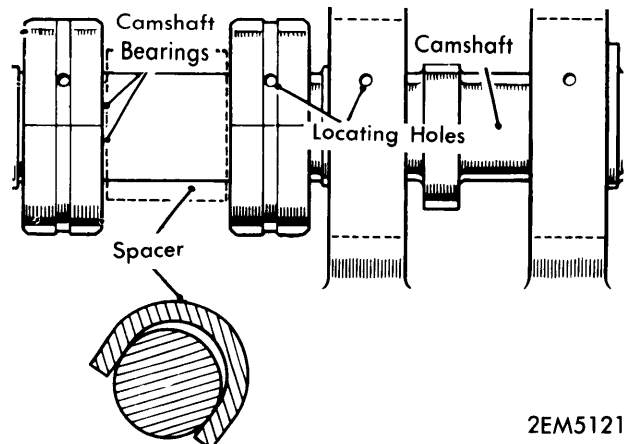

CAMSHAFT BEARING INSTALLATION

2EM5121

CAMSHAFT & BEARING REPLACEMENT

Removal - 1) With the front cover and timing gears removed, remove camshaft thrust plate.

- 2) Remove rocker shafts and rockers.
- 3) Remove distributor and short drive shaft.
- 4) Remove oil pump and distributor gear drive shaft.
- 5) Unscrew six camshaft bearing locating screws. Withdraw camshaft until bearings are clear of housings. Remove bearings by halves. Retain bearings in numbered pairs.
- 6) Withdraw camshaft and remaining rear bearings.

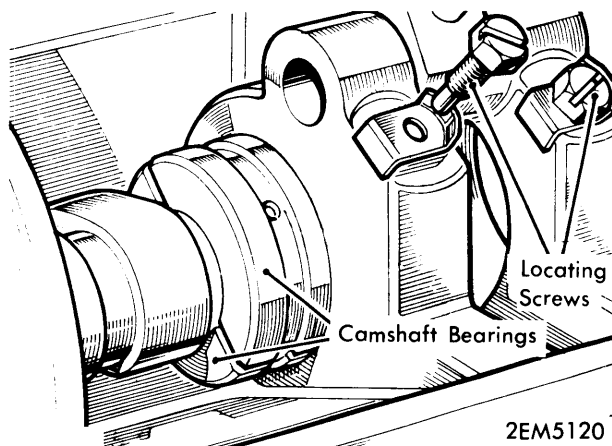

CAMSHAFT BEARING REPLACEMENT

2EM5120

Installation - 1) Before inserting bearings into block, ensure bearing halves fit together correctly on dowels by checking that no light is visible between joint faces. Fit bearings dry. They are oiled after assembly.

- 2) Insert camshaft into block, allowing distributor and oil pump drive gear to pass through first and second intermediate housing webs.
- 3) Assemble front and intermediate bearings on their proper journals, aligning their locating holes with those in block.
- 4) Install rear bearing in housing.
- 5) Place a spacer between the two inner bearings (See Illustration).
- 6) Tap camshaft until bearings are in their housings with locating holes aligned. Remove spacer.
- 7) Lubricate bearings through locating holes. Insert locating screws.
- 8) Install camshaft thrust plate and check endplay. If play is excessive replace thrust plate.
- 9) Reassemble engine and time camshaft.

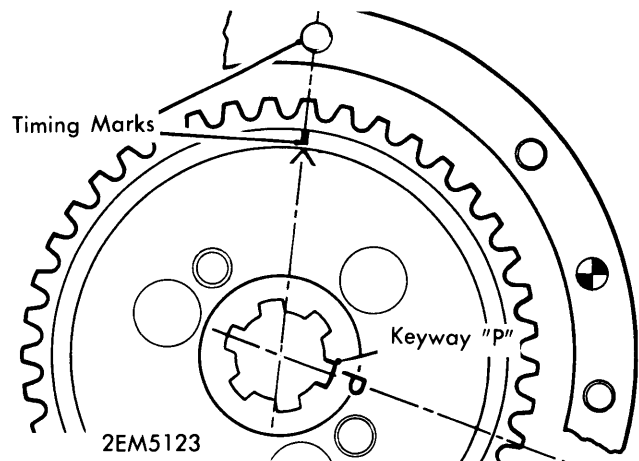

CAMSHAFT TIMING

2EM5123

TIMING CHAIN & SPROCKET REPLACEMENT

- 1) With timing cover removed, remove chain tensioner. Unscrew camshaft sprocket bolt and remove bolt, lock and washer.
- 2) Using a suitable puller remove camshaft sprocket and crankshaft sprocket. Withdraw timing chain.
- 3) Reverse procedure to reinstall chain and sprockets. See (VALVE TIMING) for sprocket alignment and chain adjustment.

VALVE TIMING				
Engine	INTAKE		EXHAUST	
	Open (BTDC)	Close (ABDC)	Open (BBDC)	Close (ATDC)
2.6 Liter	12°	46°	47°	17°

VALVE TIMING

- 1) With timing cover and pulley temporarily installed, set engine to TDC. Remove cover and pulley without moving crankshaft.

Rover Engines

1971-72 LAND ROVER 2.6 LITER 6-CYLINDER (Cont.)

2) Install camshaft sprocket, engaging the keyway marked "P". Rotate camshaft until the "V" mark is aligned with top bolt hole of timing cover.

3) Remove camshaft sprocket. Fit crankshaft sprocket with chamfered bore first, to just engage keyway.

4) Install timing chain on sprockets with no slack on drive side. Slide camshaft sprocket on keyway "P". If slack in drive

side is present, try alternate keyways on camshaft. Use care not to move camshaft. Install camshaft bolt, lock and washer.

5) Install vibration damper with .002-.010" of clearance between chain and damper.

6) Install chain tensioner and adjust, using a 1/8" Allen wrench until rubber pad touches timing chain. Do not over tighten chain tensioner.

7) Reassemble engine.

ENGINE OILING

ENGINE OILING SYSTEM

Engine lubrication is provided by a gear type oil pump. Oil is filtered by an external replaceable oil filter. Pump feeds oil under pressure to main bearings, connecting rods, camshaft bearings and valve assemblies.

Crankcase Capacity – 7.6 qts. (with filter).

Filter Type & Replacement – Paper, replace every 6,000 miles.

Normal Oil Pressure – 40-50 psi. @ 2,000 RPM.

Pressure Regulator Valve – Non-adjustable.

OIL PUMP

Removal – 1) Remove oil pan and pressure relief valve cover nut and washer. With draw pressure relief valve plunger, spring and ball.

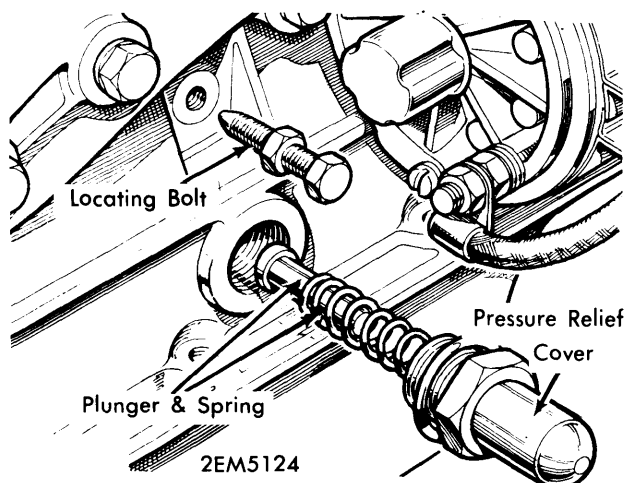

OIL PUMP REMOVAL

2) Remove oil pump locating screw. Withdraw oil pump and strainer assembly.

Disassembly – 1) Remove strainer, pump cover and gears.

2) Inspect all parts for wear. If required replace drive shaft bushing. Press in place and ream to .5635". If worn, replace idler gear bushing and drill oil hole with a .125" drill. Ream bushing to .501" diameter.

3) Replace gears in pump body with drive gear plain side of bore upward (See Illustration).

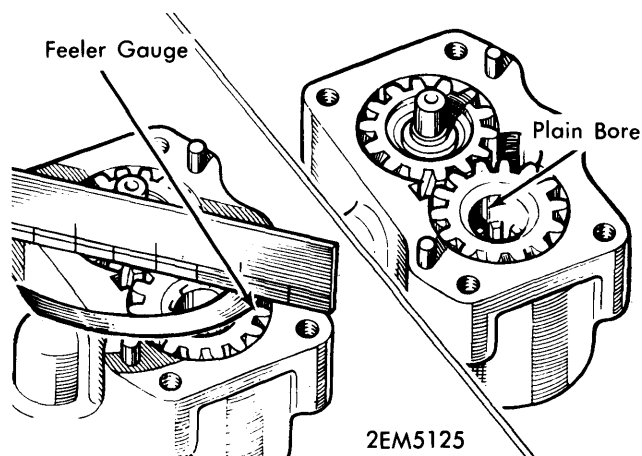

OIL PUMP BODY

4) Check gear endplay (See Specifications).

5) Reassemble and install oil pump, locating screw, pressure relief valve and oil pan.

Oil Pump Specifications

Pump Gear Endplay	
Steel Gear002-.005"
Aluminium Gear.....	.003-.006"
Radial Clearance of Gears001-.004"
Backlash.....	.008-.012"
Relief Valve Spring	
Free Length.....	3.425"
Compressed Length.....	1.990" @ 17.5 lb.

1971-72 LAND ROVER 2.6 LITER 6-CYLINDER (Cont.)

TIGHTENING SPECIFICATIONS

Application	Torque in Ft. Lbs.
Connecting Rod	20
Main Bearing Caps	75
Cylinder Head (3/8 in.).....	30
(7/16 in.).....	50
Starter Dog.....	200
Flywheel	60-65
Clutch Cover	22-25
Alternator Shaft Nut	25-30
Starter Through Bolts	8

WATER PUMP

Thermostat - Opens at 162°F.

Radiator Cap - 9 psi.