

Renault Engines

1970-71 RENAULT R-12 (810-02 ENGINE) 4 CYLINDER

GENERAL SPECIFICATIONS										
Year	Displ.		Carburetor	HP at RPM	Torque (Ft. Lbs. at RPM)	Compr. Ratio	Bore		Stroke	
	cu. ins.	cc					in.	mm	in.	mm
1970-71 R-1170	78.7	1289	1x1-Bbl.	60@5250	70@3000	8.5-1	2.874	73	3.032	77

ENGINE IDENTIFICATION

Engine number and type are stamped on a plate riveted to right side of block, below cylinder head. First five digits indicate engine type.

Model No.	Model Name	Engine Type
R-1170	R-12	810-02

ENGINE REMOVAL

- 1) Disconnect battery, drain cooling system and remove air filter. Disconnect all necessary water hoses, electrical wires, vacuum lines, fuel inlet line, accelerator linkage, and exhaust pipe.
- 2) Remove radiator and starter. Remove fan, water pump pulley and fan belt. Remove three top bolts mounting engine to transmission. Remove crossmember and secure exhaust pipe out of way.
- 3) Remove clutch shield and bottom bolts mounting engine to transmission. Attach suitable hoist to engine and take up weight. Remove crankshaft pulley. Disconnect left and right side motor mounts.
- 4) Raise engine until top of transmission meets underside of steering crossmember. Support transmission and remove left and right side engine mounts. Pull engine forward and remove from vehicle. To install, reverse removal procedure.

CYLINDER HEAD REMOVAL

- 1) Disconnect battery, drain cooling system and remove air filter. Disconnect all necessary electrical wires, water hoses and vacuum lines. Disconnect exhaust pipe, carburetor linkage, PCV valve and fuel line.
- 2) Remove generator, drive belt, distributor, and valve cover. Disconnect crossmember and secure exhaust pipe clear. Remove cylinder head bolts and slightly raise head. Remove push rods, keeping them in order for reinstallation. Remove cylinder head.
- 3) To install, reverse removal procedure, tighten all bolts to specification, and adjust valves. *NOTE - Install new head gasket dry.*

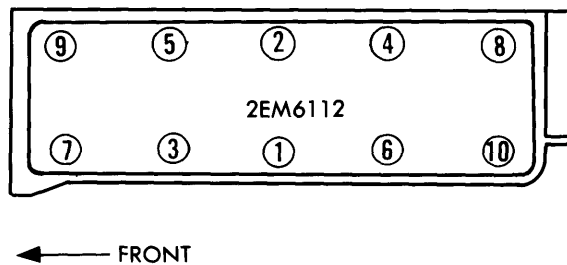

CYLINDER HEAD TIGHTENING SEQUENCE

VALVES							
Engine & Valve	Head Diam.	Face Angle	Seat Angle	Seat Width	Stem Diameter	Stem Clearance	Valve Lift
1970-71 R-1170							
Int.	1.319"	45°	45°	.043-.055"	.276"
Exh.	1.181"	45°	45°	.055-.067"	.276"

VALVE ARRANGEMENT

E-I-I-E-E-I-I-E (front to rear).

VALVE GUIDE SERVICING

1) After removing cylinder head, place it on suitable thrust plate (Mot. 121). Using a hydraulic press, force guide from head. Check extracted guide to determine its diameter. Standard size is .433", first oversize is .437" and distinguished by one index groove; second oversize is .443" and identified by

two index grooves. Always replace worn guide with closest oversize.

2) Turn head over and ream valve guide bore to fit new valve guide. Fit valve guide, chamfer outward, to mandrel and press guide into position. Ream valve guide, using suitable tool (Mot. 132 with .303" diameter).

NOTE - After installing new valve guide, reface corresponding valve seat.

1970-71 RENAULT R-12 (810-02 ENGINE) 4 CYLINDER (Cont.)

VALVE SPRING REMOVAL

Cylinder Head Installed – 1) Disconnect battery and remove valve cover. Remove spark plug and push rod corresponding to spring requiring maintenance.

NOTE – If either cylinder No. 2 or 3 are involved, remove distributor. If No. 1 cylinder is concerned, remove generator bracket.

2) Insert suitable valve retaining tool (Mot. 61) into vacant spark plug hole. Using suitable tool (Mot. 382), compress valve spring and remove retainer, top cup, and spring. Spring can now be further checked. To install, reverse removal procedure.

NOTE – Valve springs must be fitted with larger coil spacing toward cylinder head.

VALVE SPRING INSTALLED HEIGHT

Following chart indicates valve spring installed height and length under pressure. Both intake and exhaust valve springs are same.

Application	Free Length	Measurement
R-1170	1.653"9843" @ 80 Ft. Lbs.

ROCKER SHAFT ASSEMBLY

Remove water pump and end plate. Remove rocker arm shaft, take out clips, springs, rocker arms, and bearings. *NOTE* –

Plugs at end of shaft are force fitted and cannot be removed for servicing. After cleaning and inspecting, reassemble.

VALVE CLEARANCE ADJUSTMENT

With engine cold, adjust intake valves to .006" and exhaust valves to .008".

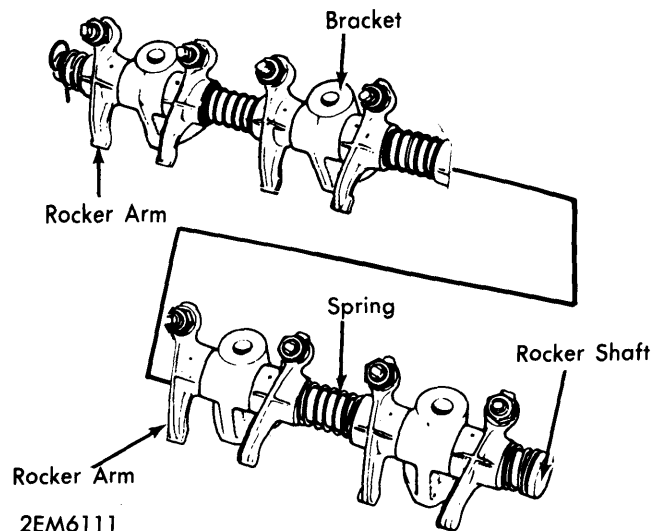

ROCKER ASSEMBLY

PISTONS, PINS, RINGS						
Engine	PISTONS Clearance	PINS		RINGS		
		Piston Fit	Rod Fit	Rings	End Gap	Side Clearance
1970-71 R-1170	①	②	③

- ① – Free Running Fit.
- ② – Press Fit at 482°F.
- ③ – Preset, No Checking Necessary.

OIL PAN REMOVAL

Raise vehicle, drain crankcase, remove crossbar brackets and tilt bar. Remove oil pan and gasket. To install, reverse removal procedure. *NOTE* – Ensure oil pan contact surface is scraped clean before installing new gasket.

PISTON & ROD ASSEMBLY

Piston and rod assembly must be inserted with No. 1 at clutch end (number stamped on connecting rod away from camshaft) and arrow on piston facing flywheel.

PISTON PIN REPLACEMENT

1) Using suitable tool assembly (Mot. 255) and hydraulic press, extract piston pin. Check piston rod alignment and correct any distortion. Check pin fit in new piston. Heat connecting rod to 482°F, before installing pin.

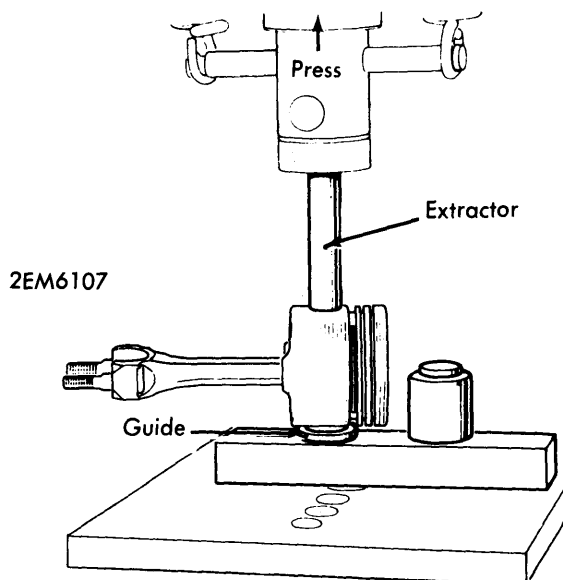

REMOVING PIN

Renault Engines

1970-71 RENAULT R-12 (810-02 ENGINE) 4 CYLINDER (Cont.)

2) Lubricate piston pin with Molykote M 55. Place connecting rod-piston assembly on support. With mandrel, hand push pin through piston, until resistance is met. Seat pin using hydraulic press. Install rings.

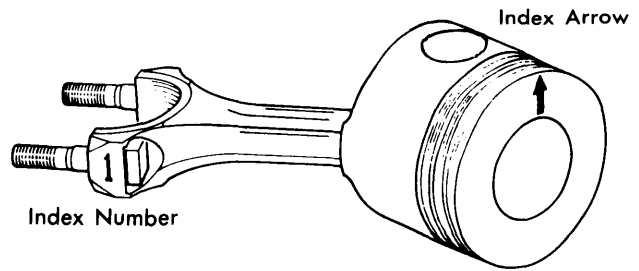

2EM6106

PISTON ASSEMBLY

FITTING PISTON

Fit piston with arrow on piston pointing upward and number on connecting rod facing left, with piston crown facing installer (see illustration).

CRANKSHAFT MAIN & CONNECTING ROD BEARINGS							
Engine	MAIN BEARINGS				CONNECTING ROD BEARINGS		
	Journal Diam.	Clearance	Thrust Bearing	Crankshaft Endplay	Journal Diam.	Clearance	Sideplay
1970-71 R-1170	1.811"	3	.002-.006"	1.731"

MAIN BEARING SERVICE

1) With engine and oil pan removed, mark main and connecting rod bearings relation to block. Remove main and connecting rod bearing caps; lift out crankshaft. Inspect bearings for wear or damage, replace as necessary.

2) Using a micrometer, check diameter of all crankshaft journals. All journals can be ground to fit .010" undersize bearings.

NOTE - All crankshaft journals are roll hardened and undercut.

3) Fit all five upper main bearings. *NOTE* - Oil holes are in same position on Nos. 1 & 3. Bearings for 2, 4, & 5 are also in same position. Fit connecting rod upper bearings. Lubricate journals and fit crankshaft into position. Install thrust washers around No. 3 main bearing.

4) Pull connecting rod over crankshaft and install bearing caps. Position main bearings and caps. *NOTE* - Lower main bearings do not have oil holes. Tighten all bolts to specification. Ensure crankshaft turns freely.

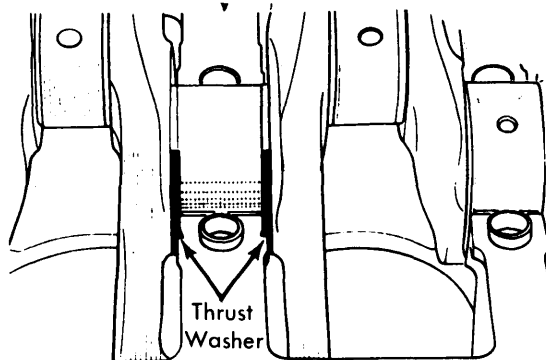

2EM6110

THRUST WASHER INSTALLATION

5) Using a dial gauge, check crankshaft endplay. Ensure it is between .002-.006". If tolerance is exceeded, replace thrust washers. Washers are available in standard (.090") and two oversizes (.094" and .096").

REAR MAIN BEARING OIL SEAL

Using suitable tool (Mot. 131-02), install main bearing oil seal. Fit seal on tool and lubricate outer edge of seal. If a new crankshaft is being installed at same time, seal should be seated in original position. If crankshaft is being reused, tilt seal approximately 1/8" forward, so new seal is not in same position as original. In both instances, tap gently on shaft of tool until tool just touches cylinder block.

NOTE - Exercise caution as lip of seal is easily damaged.

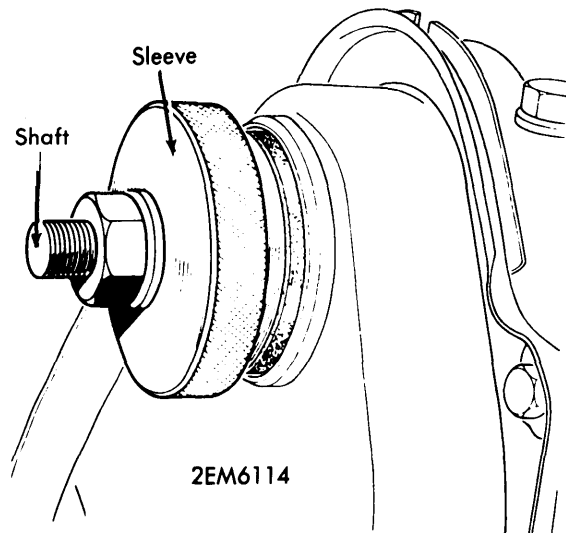

2EM6114

INSTALLING OIL SEAL

1970-71 RENAULT R-12 (810-02 ENGINE) 4 CYLINDER (Cont.)

TIMING CHAIN COVER & OIL SEAL

With engine removed, withdraw timing cover bolts and lift off cover and gasket. **NOTE** — Before engine is removed, crankshaft pulley is extracted. When cover is removed oil seal can be replaced if necessary. To install, reverse removal procedure. **NOTE** — Ensure cover is scraped clean before installing new gasket.

TIMING COVER OIL SEAL

1) With engine in vehicle, disconnect battery. Remove water pump belt and crankshaft pulley. Fit extractor tool (Mot. 457) fully into position (seal lip behind shoulder of tool). Extract seal by turning bolt inward.

2) To install, place seal in centering sleeve and put assembly against timing cover. Draw seal up until sleeve just meets crankshaft. Position crankshaft pulley and water pump drive belt.

CAMSHAFT			
Engine	Journal Diam.	Clearance	Lobe Lift
1970-71 R-1170

CAMSHAFT REMOVAL

1) With engine removed, suitably supported, and timing cover off, disengage chain tensioner. Insert a 3 mm Allen wrench into chain tensioner and turn it clockwise until chain is no longer under tension.

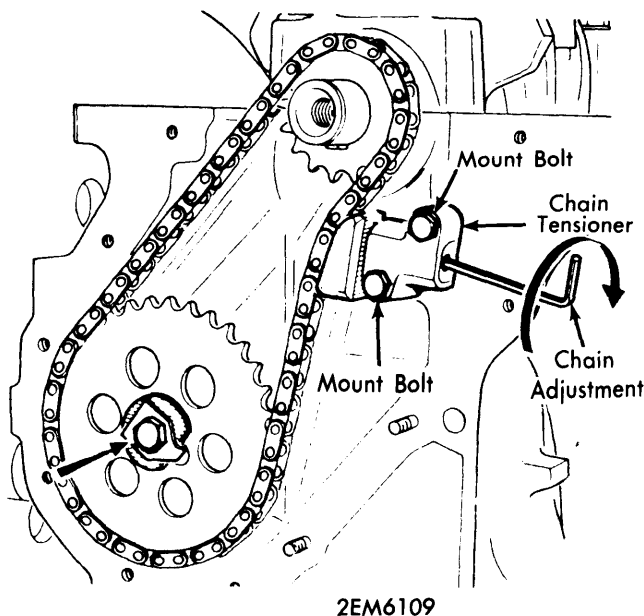

CHAIN TENSIONER — CORRECT ADJUSTMENT

2) Remove tensioner, plate, and damper/filter. Remove camshaft bolt, sprocket and chain. Extract camshaft flange screws and remove camshaft.

3) Lubricate camshaft bearings and fit shaft, tighten camshaft bolts. Fit camshaft sprocket, with timing marks facing outward, as shown in illustration.

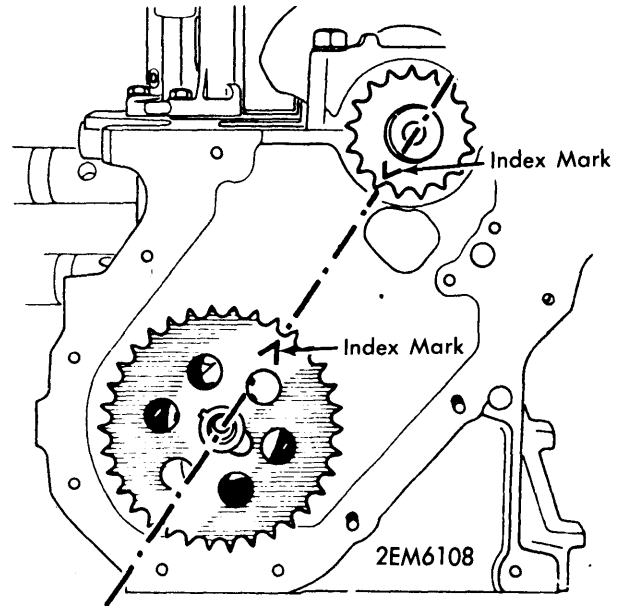

CAMSHAFT & CRANKSHAFT ALIGNMENT

4) Fit timing chain on crankshaft sprocket and camshaft sprocket. Tighten camshaft bolt to specification and reverse removal procedure for remaining components. **NOTE** — Ensure timing chain is properly adjusted (see illustration).

CAMSHAFT ENDPLAY

Check flange endplay after fitting sprocket and tightening bolts to specification. Endplay must not exceed .002-.005". If tolerance is exceeded, replace flange.

Engine	VALVE TIMING			
	INTAKE		EXHAUST	
	Open (BTDC)	Close (ABDC)	Open (BBDC)	Close (ATDC)
1970-71 R-1170	20°	60°	60°	20°

TIMING CHAIN REMOVAL

1) With engine removed, suitably supported, and timing cover off, disengage chain tensioner. Insert a 3 mm Allen wrench and turn it clockwise until chain is no longer under tension.

Renault Engines

1970-71 RENAULT R-12 (810-02 ENGINE) 4 CYLINDER (Cont.)

2) Remove tensioner, plate, and damper/filter. Remove camshaft bolt, sprocket and chain.

3) To install, fit camshaft sprocket, with timing marks facing outward, as shown in illustration. Fit timing chain on crankshaft sprocket and tighten bolt to specification.

VALVE TIMING

Ensure timing marks on crankshaft and camshaft are properly aligned, as shown in illustration.

ENGINE OILING

Crankcase Capacity — Approximately 3 1/4 quarts.

Oil Filter — Disposable canister type.

Normal Oil Pressure — 10 psi at 600 RPM and 50-55 psi at 4,000 RPM.

OIL PUMP

1) Remove oil pan and three mounting bolts. Remove cover bolts, relief valve seat, valve ball, and spring. **NOTE** — Assembly is under spring tension. Completely disassemble remaining components of oil pump.

2) Clean and inspect all parts. Measure endplay between gears and pump body, tolerance is .008". If specification is exceeded, change gears. To reassemble and install, reverse removal procedure.

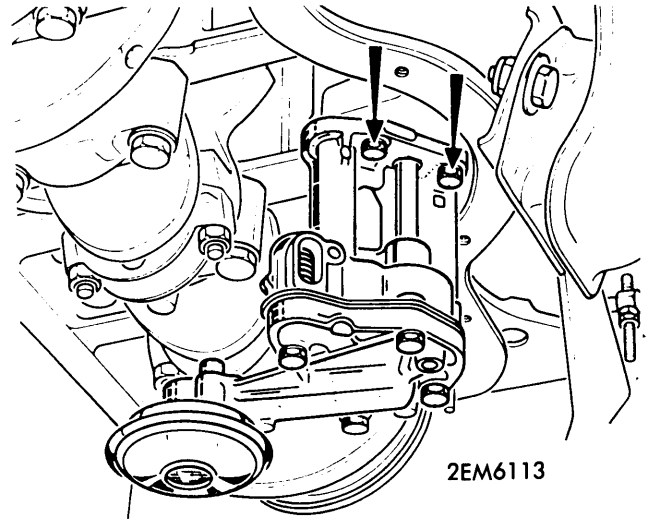

OIL PUMP INSTALLED

ENGINE COOLING

WATER PUMP

Disconnect battery and drain cooling system. Disconnect all radiator hoses. Remove radiator, water pump pulley, and drive belt. Remove water pump. To install, reverse removal procedure

NOTE — If pump is hard to free, tap lightly with a plastic hammer.

Cooling System Capacity — Approximately 5 1/2 quarts.

TIGHTENING SPECIFICATIONS

Application	Ft. Lbs.
Cylinder Head	40-50
Connecting Rods	30-35
Camshaft Sprocket Bolt	15
Main Bearings	40-50
Flywheel	35