

Porsche Engines

1970-73 PORSCHE (914 SERIES) 4 CYLINDER

GENERAL SPECIFICATIONS										
Year	Displ.		Carburetor	HP at RPM	Torque (Ft. Lbs. at RPM)	Compr. Ratio	Bore		Stroke	
	cu. ins.	cc					in.	mm	in.	mm
1970-72										
W	102.5	1679	①	85@5000	99@3500	8.2-1	3.543	90	2.598	66
1973										
EA	102.5	1679	①	80@4900	101@2700	8.2-1	3.543	90	2.598	66
EB	102.5	1679	①	72@5000	90@2700	7.3-1	3.543	90	2.598	66
GA	120.3	1971	①	95@4900	109@3500	7.6-1	3.701	94	2.795	71

① – Electronic Fuel Injection

ENGINE IDENTIFICATION

Engine serial number of 1679 cc engine is stamped on upper left side of crankcase below breather tube. Engine serial number of 1971 cc engine is stamped on the upper part of crankcase between oil filler neck and blower housing.

Application

Code

1970-72	
All Models	W
1973	
1679 cc (Exc. Calif.)	EA
1679 cc (Calif.)	EB
1971 cc (914S)	GA

ENGINE REMOVAL

NOTE – Engine and transmission must be removed as an assembly.

- 1) Mark position of rear luggage compartment hood-to-hinges and remove hood. Disconnect battery ground cable. Remove air cleaner and heating air hoses.
- 2) Disconnect electrical connections from fuel injection components and place wire harness out of way. Disconnect throttle cable and push through engine cover plate.
- 3) Bend fuel line bracket tabs back and disconnect and plug fuel lines near pressure feeler. Remove starter retaining nuts. Raise vehicle and remove muffler molding.
- 4) Remove lower warm air flow components. Remove protective cover and remove shift rod holder. Remove protective cover, remove bolts and rear shift rod.
- 5) Remove heater flap box, hoses and cables. Loosen clutch cable adjusting nut for guide roller and pull clutch cable forward. Disconnect speedometer cable and pull forward.
- 6) Remove starter and disconnect ground strap on luggage pan. Remove axle shafts at transmission and secure to body with wire holders.
- 7) Lower vehicle slightly and place floor jack with a suitable engine holder (VW612/4) and transmission support (VW612/3) attached under engine. Raise floor jack slightly.
- 8) Remove transmission support bolts and right engine mount bolt. Carefully lower and remove engine and transmission assembly. Separate engine from transmission.

9) To install engine and transmission, reverse removal procedure noting the following procedures. Inspect clutch throw-out bearing for wear. Coat bushing for throw-out bearing and starter shaft bushing with MOS2 paste.

10) When installing engine and transmission, make sure fuel lines are not pinched and parking brake cables are above engine.

11) Adjust freeplay of clutch. Align engine compartment seal in proper position. Adjust throttle cable. Carefully connect fuel injection wires and protective caps. Tighten all bolts and nuts to specifications.

CYLINDER HEAD INSTALLATION

- 1) With cylinder head removed, check combustion chambers and exhaust ports for cracks. Replace cylinder head if cracked. Check spark plug hole threads for damage and install a helicoil if necessary.
- 2) When installing cylinder heads, replace sealing rings. Slightly tighten all nuts and then tighten to specification in sequence shown in illustration. Install baffle plate.

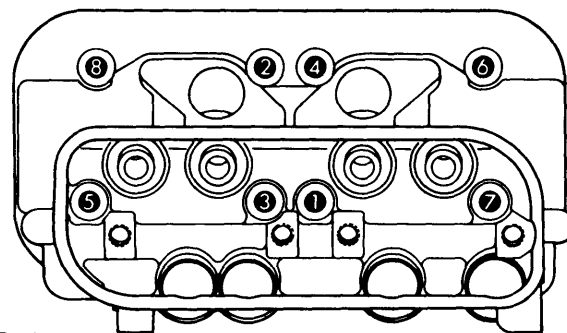

2EM5239

CYLINDER HEAD TIGHTENING SEQUENCE

1970-73 PORSCHE (914 SERIES) 4 CYLINDER (Cont.)

VALVES								
Engine & Valve	Head Diam. In. (mm)	Face Angle	Seat Angle	Seat Width In. (mm)	Stem Diameter In. (mm)	Stem Clearance In. (mm)	Valve Lift In. (mm)	
1679 cc	Int.	1.54 (39.1)	30°	30°	.0708-.0866 (1.8-2.0)	.3126-.3130 (7.94-7.95)	.0177 (.45)
	Exh.	1.30 (33.0)	45°	45°	.0787-.0984 (2.0-2.5)	.3508-.3512 (8.91-8.92)	.0177 (.45)
1971 cc	Int.	1.654 (42.0)	45°	45°	.0708-.0866 (1.8-2.0)	.3126-.3130 (7.94-7.95)	.0177 (.45)
	Exh.	1.417 (36.0)	45°	45°	.0787-.0984 (2.0-2.5)	.3508-.3512 (8.91-8.92)	.0177 (.45)

VALVE ARRANGEMENT

E-I-I-E

VALVE GUIDE SERVICING

With cylinder head disassembled, check clearance between valve and valve guide with a new valve. Measure clearance by checking distance valve rocks in guide with a dial indicator. If valve rocks more than .0354", replace cylinder head.

VALVE STEM OIL SEALS

A rubber "O" ring type seal is installed on valve stem, before valve spring is installed.

VALVE SPRING REMOVAL

1) With cylinder head removed, compress valve spring with a suitable valve spring compressor (VW311s) and remove valve keepers. Release spring compressor and remove spring retainer and spring.

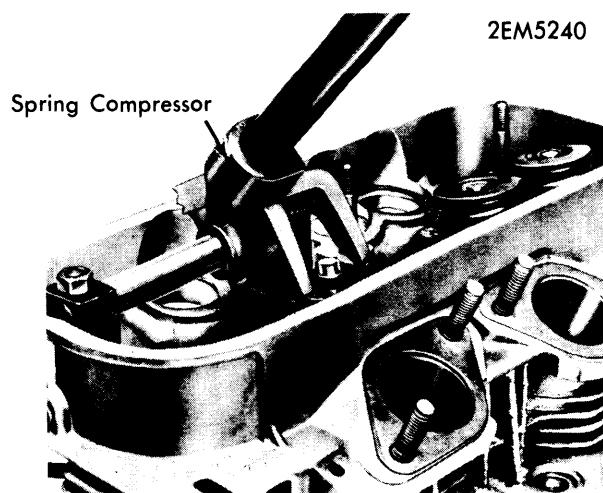

VALVE SPRING REMOVAL

2) Check valve spring in a spring tester. With 160-184 lbs. applied to spring in tester, length of spring should be 1.2". To install, coat valve stem with molybdenum disulfide paste and install in valve guide. Install valve spring using a suitable valve spring compressor (VW311s) and install valve keepers.

ROCKER ARM ASSEMBLY

1) With rocker arm assembly, push rod tubes and valve tappets removed, check valve tappet face and sides for wear or scoring. If diameter of tappet is less than .9421", replace tappet.

2) Check rocker arms and shafts for wear. If inside diameter is more than .7890", replace rocker arm. If diameter of shaft is less than .7846", replace rocker shaft.

3) To install components, lubricate tappet with oil and insert in crankcase. Install push rod tubes with new seals. Slide shaft support stands on rocker shafts so slots face down when installed on engine.

4) Install rocker arm assemblies and tighten nuts to specifications. Install push rod tube securing clip. Clip is secured to head by sliding into slots in rocker arm shaft support stands. Adjust valve clearance. See *Valve Clearance Adjustment*.

VALVE CLEARANCE ADJUSTMENT

Valve clearance is checked or adjusted with engine cold. Rotate engine until piston of valve being adjusted is at TDC of compression stroke. Both valves can be adjusted at same time. Adjust both intake and exhaust valves to .006".

Application	Valve Clearance Adjustment In. (mm)
1679 cc	
Intake & Exhaust006 (.15)
1971 cc	
Intake006 (.15)
Exhaust008 (.20)

Porsche Engines

1970-73 PORSCHE (914 SERIES) 4 CYLINDER (Cont.)

PISTONS, PINS, RINGS						
Engine	PISTONS	PINS		RINGS		
	Clearance In. (mm)	Piston Fit In. (mm)	Rod Fit In. (mm)	Rings	End Gap In. (mm)	Side Clearance In. (mm)
1679 cc	.0016-.0024 (.41-.61)	①	.0008-.0012 (.02-.03)	No. 1	.0138-.0216 (.35-.55)	.0024-.0035 (.06-.09)
				No. 2	.0018-.0138 (.05-.35)	.0016-.0028 (.04-.07)
				No. 3	.0098-.0157 (.25-.40)	.0008-.0020 (.02-.05)
1971 cc	.0007-.0021 (.02-.05)	①	.0008-.0012 (.02-.03)	No. 1	.0138-.0216 (.35-.55)	.0024-.0035 (.06-.09)
				No. 2	.0018-.0138 (.05-.35)	.0016-.0028 (.04-.07)
				No. 3	.0098-.0157 (.25-.40)	.0008-.0020 (.02-.05)

① — Push fit, but no more than .0016" (.04 mm) clearance.

CYLINDER INSTALLATION

NOTE — Mark cylinders before removing to insure that they are installed on same piston.

1) Thoroughly clean and inspect cylinder before installation. Make sure sealing edges on both ends of cylinder are clean. Lubricate piston and pin with oil before installing cylinder.

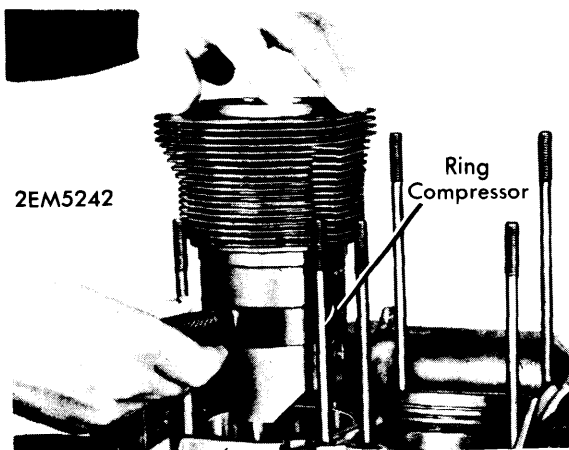

CYLINDER INSTALLATION

2) Compress piston rings with a suitable ring compressor. Make sure oil ring gap is to top and install cylinder with new sealing ring on bottom. Make sure studs do not touch cooling fins of cylinder.

PISTON INSTALLATION

NOTE — Mark piston before removal to insure that it is installed on same rod and in same cylinder.

1) With cylinder removed, remove circlips from piston pin hole. Remove piston pin with a suitable mandrel (VW207c) and remove piston. Remove rings if they are to be replaced.

2) Thoroughly clean and inspect pistons. Make sure ring grooves are clean before installing rings. When installing

rings, make sure side of ring marked "TOP" is toward head of piston.

3) Insert circlips in pistons one and two in side facing flywheel and in opposite side on pistons three and four. Position pistons on connecting rod so arrows are facing toward flywheel.

4) Install piston pin with a suitable mandrel (VW207c). If pin does not slide in manually, heat piston to approximately 176°F and install piston pin and remaining circlip.

2EM5243

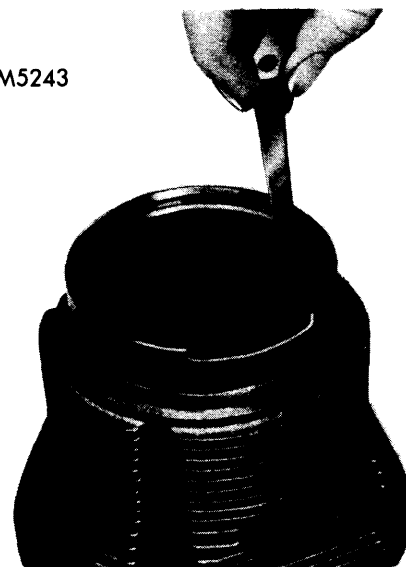

RING END GAP

FITTING PISTONS

1) With piston and cylinder removed, measure clearance between piston and cylinder. Check piston size at bottom of skirt and at 90° to center line of piston pin. Measure cylinder at .4" to .6" below top of cylinder.

1970-73 PORSCHE (914 SERIES) 4 CYLINDER (Cont.)

2) If clearance exceeds .0079", replace piston and cylinder. Rated size of piston is stamped in top and nominal size of pistons and cylinders is designated by colors. Pistons and cylinders with same standard size and same color codings must be installed in engine.

Standard Size & Code	Piston Specifications	
	Pistons In. (mm)	Pistons In. (mm)
3.54" (89.9 mm)		
Blue	3.5429-3.5433 (89.99-90.00)	3.5413 (89.95)
Pink	3.5433-3.5437 (90.00-90.01)	3.5417 (89.96)
Green	3.5437-3.5441 (90.01-90.02)	3.5421 (89.97)
3.56" (90.4 mm)		
Blue	3.5626-3.5630 (90.49-90.50)	3.5610 (90.45)
Pink	3.5630-3.5633 (90.50-90.51)	3.5614 (90.46)
Green	3.5634-3.5638 (90.51-90.52)	3.5618 (90.47)

Standard Size & Code	Piston Specifications (Cont.)	
	Pistons In. (mm)	Pistons In. (mm)
3.58" (90.9 mm)		
Blue	3.5823-3.5826 (90.99-91.00)	3.5807 (90.95)
Pink	3.5827-3.5830 (91.00-91.01)	3.5811 (90.96)
Green	3.5831-3.5835 (91.01-91.02)	3.5815 (90.97)
3.70" Mahle (94.0 mm)		
Blue	3.7005-3.7011 (93.99-94.01)	3.6990-3.6996 (93.95-93.97)
Pink	3.7009-3.7015 (94.00-94.02)	3.6994-3.7000 (93.96-93.98)
3.70" Schmitt (94.0 mm)		
Blue	3.7005-3.7011 (93.99-94.01)	3.6991-3.6997 (93.96-93.97)
Pink	3.7009-3.7015 (94.00-94.02)	3.6995-3.7001 (93.97-93.98)

CRANKSHAFT MAIN & CONNECTING ROD BEARINGS							
Engine	MAIN BEARINGS				CONNECTING ROD BEARINGS		
	Journal Diam. In. (mm)	Clearance In. (mm)	Thrust Bearing	Crankshaft End Play In. (mm)	Journal Diam. In. (mm)	Clearance In. (mm)	Side Play In. (mm)
All			No. 1	.0028-.0051 (.07-.13)	2.1646-2.1654 (54.98-55.00)	.0008-.0028 (.02-.07)	.0039-.0157 (.10-.40)
Journal No. 1,2 & 3	2.3610-2.3618 (59.97-59.99)	.0020-.0039 [ⓐ] (.05-.10)					
No. 4 (1679 cc)	1.5740-1.5748 (39.98-40.00)	.0020-.0039 (.05-.10)					
No. 4 (1971 cc)	1.6533-1.6538 (41.99-42.01)	.0020-.0039 (.05-.10)					

ⓐ — Clearance for No. 2 journal is .0012-.0035" (.03-.09 mm).

CRANKCASE ASSEMBLY

NOTE — When separating crankcase halves, use a rubber hammer. Do not insert a screwdriver between mating surfaces of crankcase.

1) Thoroughly clean and inspect both crankcase halves. Remove old sealing compound from mating surfaces. Chamfer edges of bearing bores if necessary. Blow out oil passages with compressed air.

2) Assembly empty crankcase halves and tighten bolts and nuts to specifications. Check camshaft and crankshaft bearing bores with an inside micrometer. If measurements exceed those specified, replace crankcase halves.

3) To assemble crankcase halves, install bearing dowel pins, number two bearing halves and camshaft bearings. Apply sealing compound to mating surfaces, making sure sealer does not enter any oil passages.

4) Position crankshaft and rod assembly in left side crankcase half, making sure dowel pins are properly seated in bearings. Install camshaft. See *Camshaft Installation*.

5) Install camshaft plug and join crankcase halves. Lightly tighten oil pickup tube screw. Tighten M10 nuts first, then tighten remaining nuts. Make sure crankshaft rotates freely.

Crankcase Bearing Bore Specifications		
Application	Bore	In. (mm)
Crankshaft	No. 4	1.9701 (50.0)
Crankshaft	No. 1-3	2.7571 (70.0)
Camshaft	No. 1-3	1.0843 (27.5)

1970-73 PORSCHE (914 SERIES) 4 CYLINDER (Cont.)

MAIN & CONNECTING ROD BEARING SERVICE

1) With crankshaft and connecting rod assembly removed, remove snap ring securing distributor drive gear and crankshaft gear to crankshaft. Remove distributor drive gear and crankshaft gear by pressing or using a suitable mandrel (VW457). Remove number three bearing. Remove connecting rods.

2) Thoroughly clean and inspect crankshaft. Blow out oil passages with compressed air. Check runout of crankshaft, if runout is more than .0008", regrind crankshaft to next undersize.

3) Check crankshaft journals for wear, if journals are worn more than .0012", regrind crankshaft to next undersize. Main and connecting rod bearings are available in .010", .020" and .030" undersize.

4) Lubricate and install number three bearing. Heat crankshaft to approximately 176°F in an oil bath and install crankshaft and distributor drive gears using suitable drivers (VW427, VW428 and VW415a). Install snap ring.

5) Thoroughly clean and inspect connecting rods for damage. Replace if bolts are damaged. Check pin fit in connecting rod, if fit is too loose, replace pin bushing. See *Piston Pin Bushing Replacement*.

6) Install bearing halves in connecting rod and cap. Install on crankshaft with numbers on rod and cap on same side. Tighten nuts to specifications. Secure nuts by peening to rod.

7) Check connecting rod side play with a feeler gauge. If side play exceeds .026", replace connecting rod. Install crankshaft and connecting rod assembly as previously outlined. Check crankshaft endplay. See *Crankshaft Endplay*.

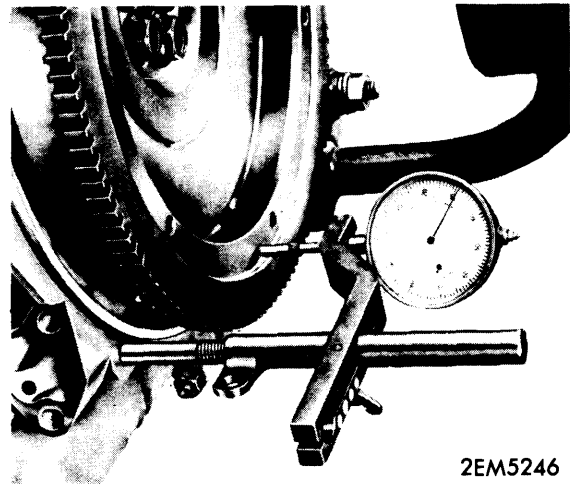

2EM5246

CRANKSHAFT END PLAY

2) If measurement exceeds specified endplay, install a suitable size shim to obtain correct endplay. The thickness of shim is etched in face of shim. Always install three shims to obtain correct endplay. Shims are available in the following thickness:

MM Markings On Shim	Inch Equivalent
.24 mm0094"
.30 mm0118"
.32 mm0126"
.34 mm0134"
.36 mm0142"
.38 mm0150"

3) With correct shim thickness determined, install crankshaft oil seal. See *Front Crankshaft Oil Seal Replacement*. Install flywheel, tighten bolts to specifications and recheck crankshaft end play.

FRONT CRANKSHAFT OIL SEAL REPLACEMENT

1) Remove flywheel and pry out crankshaft oil seal. Make sure seal seat in crankcase is clean. If necessary chamfer edges of seal seat.

2) Press seal into crankcase using a suitable seal installer (VW191). Make sure seal is seated in bottom of crankcase. Lubricate sealing edge of seal, install flywheel and tighten bolts to specifications.

REAR CRANKSHAFT OIL SEAL REPLACEMENT

1) Remove cooling blower impeller from rear of engine. See *appropriate story in Engine Cooling Section*. Remove cooling blower impeller hub with a suitable puller (VW185).

2) Pry out old seal and thoroughly clean seal seat in crankcase. Chamfer edges of seal seat if necessary. Press seal into crankcase using a suitable seal installer (VW190). Make sure seal is seated in bottom of crankcase. Lubricate sealing edge of seal and install cooling blower impeller.

DISTRIBUTOR DRIVE INSTALLATION

When crankcase has been assembled, and remaining components installed, distributor drive must be installed in correct position. Rotate crankshaft until number one piston is at TDC

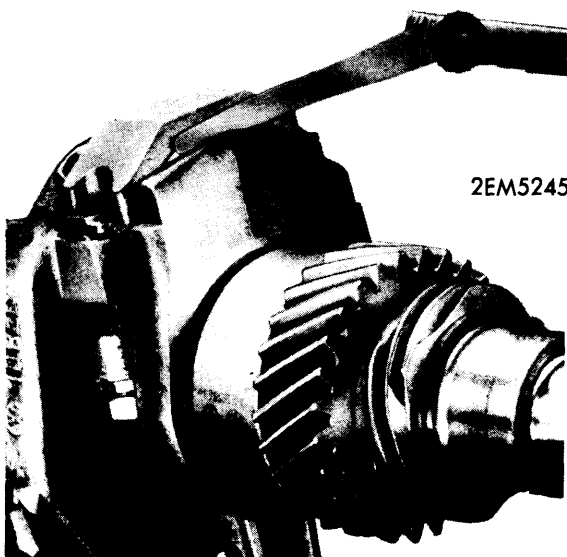

2EM5245

CONNECTING ROD SIDE CLEARANCE

CRANKSHAFT ENDPLAY

NOTE — Crankshaft endplay is checked with engine assembled.

1) Install flywheel with two shims, but do not install crankshaft oil seal. Attach dial indicator to crankcase and measure back and forth movement of crankshaft.

1970-73 PORSCHE (914 SERIES) 4 CYLINDER (Cont.)

of compression stroke. Install distributor drive with slot at a 12° angle to center line of engine with small segment of slot toward outside of vehicle (see illustration).

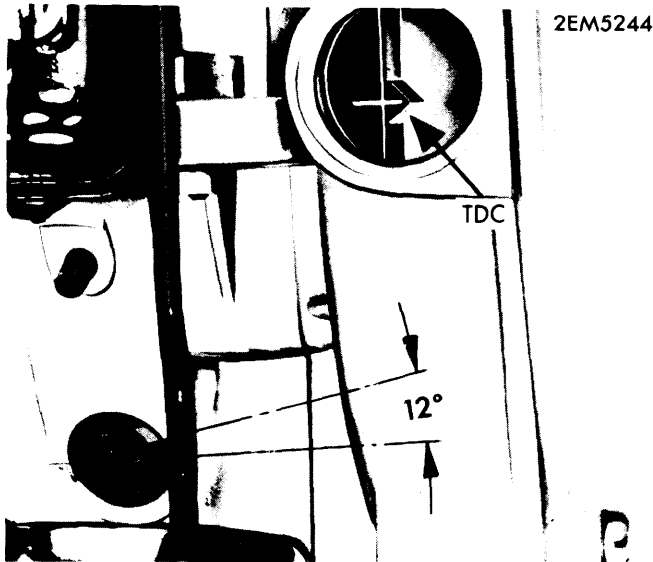

DISTRIBUTOR DRIVE INSTALLATION

PISTON PIN BUSHING REPLACEMENT

1) At normal temperature, piston pin should push fit in connecting rod. If side clearance is felt with a new pin installed, bushing must be replaced and reamed to correct fit with a new piston pin.

2) Press bushing out using a suitable mandrel and components (VW402, 409, 421 and 416B). Install new bushing using same procedure and tools as used for removal.

3) Drill through oil holes in connecting rod. Ream bushing to .9455-.9458" with a reamer. Bushing should be free of chatter marks when reaming is completed. Piston pin should push fit into bushing without oil.

CAMSHAFT			
Engine	Journal Diam. In. (mm)	Clearance In. (mm)	Lobe Lift In. (mm)
All	.9839-.9843 (24.99-25.00)	.0008-.0020 (.02-.05)

CAMSHAFT INSTALLATION

1) With camshaft removed, check riveting of camshaft gear to camshaft. Check camshaft for runout, if runout exceeds .0016", replace camshaft.

2) Check gear backlash with camshaft and crankshaft installed in crankcase half. Correct backlash is .002". Gears have correct fit when crankshaft is rotated backwards and camshaft does not try to rise out of bearings.

3) If camshaft rises out of bearings, teeth on camshaft gear have the wrong pitch radius for crankshaft gear. Camshafts with gears that have various pitch radii are available. Pitch radius is stamped on back of gear facing number three bearing journal of camshaft.

4) Install camshaft with "O" stamped in tooth on outside of camshaft gear between two teeth with punch marks on crankshaft gear. Assemble crankcase halves as previously outlined.

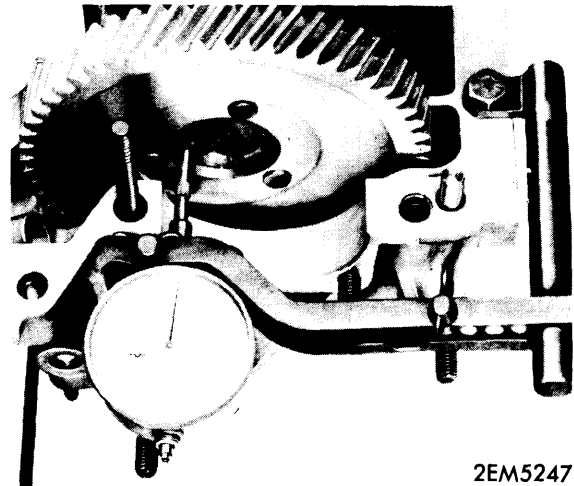

CAMSHAFT END PLAY

CAMSHAFT END PLAY

Camshaft end play is checked with camshaft installed in crankcase half. Measure back and forth movement of camshaft with a dial indicator. If endplay exceeds .0063", replace camshaft or camshaft bearings.

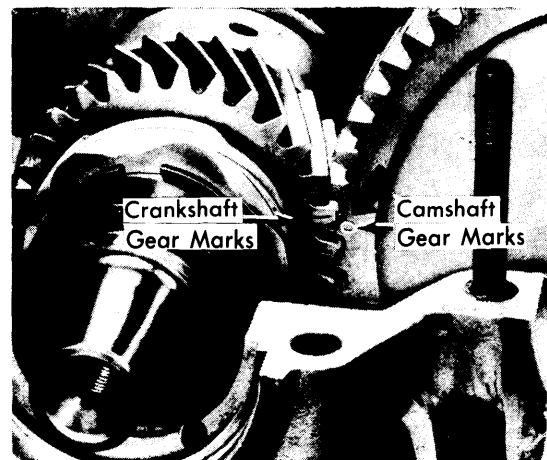

CAMSHAFT INSTALLATION

1970-73 PORSCHE (914 SERIES) 4 CYLINDER (Cont.)

VALVE TIMING				
Engine	INTAKE		EXHAUST	
	Open (BTDC)	Close (ABDC)	Open (BBDC)	Close (ATDC)
All	12°	42°	43°	4°

VALVE TIMING

Install camshaft with "O" stamped in tooth on outside of camshaft gear between two teeth with punch marks on crankshaft gear.

ENGINE OILING

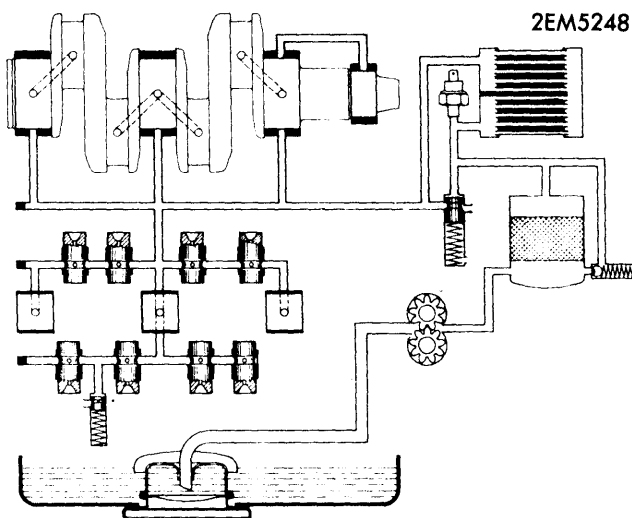

ENGINE LUBRICATION SYSTEM

ENGINE OILING SYSTEM

Full pressure lubrication system utilizing a gear type oil pump installed in rear of engine and driven by the camshaft. Oil is pumped through oil filter, oil cooler and into main oil passages in crankcase. Crankshaft main and connecting rod journals are oiled through crossdrilled oil passages in crankcase. Oil is pumped to camshaft through oil passages that also lubricate valve tappets. Oil flows through push rods to lubricate rocker arms and shafts. Valve stems are lubricated by splash oil from rocker arms. Excess oil flows back into crankcase through push rod tubes. Cylinder walls and piston pins are lubricated by splash oil.

Oil Capacity — 3.2 quarts. 3.7 quarts with filter change.

Oil Pressure — 42 psi at 2500 RPM with engine at 158°F.

Oil Filter — Full flow oil filter.

Pressure Regulator Valve — Located in crankcase below breather. Remove plug, spring and valve. Check plug and bore in crankcase for wear or signs of seizure. Apply 3.7-4.4 lbs. to spring, if length is more than 1.023", replace spring.

OIL PUMP

1) Cooling shrouds, blower impeller and related components must be removed from rear of engine to remove oil pump. See *Engine Cooling*. Remove nuts securing oil pump to crankcase and pry pump out of crankcase, prying equally on both sides.

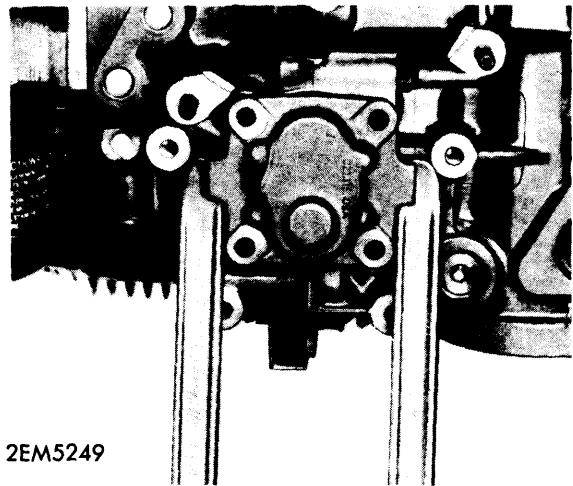

OIL PUMP REMOVAL

2) With pump removed, remove four nuts from pump cover and remove cover with a suitable puller (VW803). Pull out drive gear and driven gear. Thoroughly clean and inspect all components for signs of wear or damage and replace as necessary.

3) To assemble, lubricate drive gear and driven gear and insert in oil pump housing. Install oil pump cover with new sealing ring lubricated and installed in housing. Tighten nuts and check rotation of gears.

4) To install oil pump, insert a new seal in crankcase. Position drive gear shaft so drive portion of shaft is aligned with slot in camshaft and install oil pump in crankcase. Rotate crankshaft two revolutions to center oil pump and tighten nuts.

1970-73 PORSCHE (914 SERIES) 4 CYLINDER (Cont.)

ENGINE COOLING

Thermostat – Starts opening at 149-158°F.

Cooling Volume – 1,699 cfm@4600 RPM.

COOLING SYSTEM

Engine is cooled by a radial blower mounted to rear end of crankshaft. Blower draws air through opening in blower shroud at rear of engine. Blower shroud is two piece, mounted around blower and attached to crankcase. As air is drawn in shroud, it is directed over finned cylinders and cylinder heads by deflector plates. A thermostat is mounted under number one and two cylinders and actuates flaps mounted in shroud to control volume of air directed into deflector plates. As engine warms up thermostat opens flaps completely to allow total flow of air.

BLOWER SHROUD REMOVAL

1) Remove engine as previously outlined. Remove left and right rear engine cover plates. Loosen alternator mount and remove drive belt.

2) Remove three Allen bolts from cooling blower and remove blower and pulley. Remove spacing washer and alternator cover plate. *NOTE* – Alternator does not need to be removed to remove blower shroud.

3) Disconnect flap actuating cable from control shaft. Remove nuts securing shroud to crankcase and remove both halves of blower shroud.

4) To install, reverse removal procedure. Adjust air flap control by pushing flaps into closed position and tighten cable control. Attach elbow for cooling alternator to front fan shroud half.

5) Install drive belt and tighten alternator in a position so that belt depresses no more than .6" when pushed with thumb. Install cover plates and engine as previously outlined.

TIGHTENING SPECIFICATIONS

Application	Ft. Lbs. (mkg)
Cylinder Head Nuts	23.1 (3.2)
Crankcase Nuts M8	14.5 (2.0)
Crankcase Nuts M10	23.9 (3.3)
Connecting Rod Nuts ^①	23.9 (3.3)
Rocker Arm Assembly Nuts	10.1 (1.4)
Blower Hub Bolt	23.1 (3.2)
Blower-to-Hub Bolts	14.5 (2.0)
Oil Pump Nuts	14.5 (2.0)
Flywheel Bolts	79.6 (11.0)
Engine-to-Body Nuts	21.7 (3.0)
Transmission Support Nuts	14.5 (2.0)
Engine-to-Transmission Nuts	21.7 (3.0)
Engine Support Nuts	21.7 (3.0)
Carrier Plate Bolts	61.5 (8.5)
Crankshaft Pulley	43.4 (6.0)
Oil Drain Plug	15.9 (2.2)
Oil Strainer Cover Nut	9.4 (1.3)

① – Use new connecting rod nuts.