

1973 MERCEDES-BENZ (M110) 6 CYLINDER

| GENERAL SPECIFICATIONS | | | | | | | | | | |
|------------------------|----------|------|------------|-----------|--------------------------|--------------|------|----|--------|------|
| Year | Displ. | | Carburetor | HP at RPM | Torque (Ft. Lbs. at RPM) | Compr. Ratio | Bore | | Stroke | |
| | cu. ins. | cc | | | | | in. | mm | in. | mm |
| 1973 | 167.6 | 2746 | 1x4-Bbl. | 158@5500 | 166@4000 | 8.0-1 | 3.39 | 86 | 3.10 | 78.8 |

► CHANGES, CAUTIONS, CORRECTIONS

See "Engine Notes" at end of article.

ENGINE IDENTIFICATION

Engine number is stamped on right side of engine above forward exhaust manifold. Engine is a six cylinder double overhead cam type referred to as an M110.

| Model | Type | Engine Code |
|-----------|--------------|-------------|
| 280..... | 114.060..... | 110.921 |
| 280C..... | 114.073..... | 110.921 |

ENGINE REMOVAL

1) Remove radiator and fan. Vehicles with level control, remove pump from engine and place aside with hoses connected. On vehicles with air conditioning, remove compressor and set aside with hoses connected.

2) Drain oil supply tank and disconnect power steering hoses from pump. Remove retaining ring from longitudinal accelerator shaft and push toward firewall to remove.

3) Disconnect all water, vacuum, oil and electrical lines leading to engine. Disconnect exhaust pipes from manifold and strut on transmission. Attach suitable lifting sling and remove engine mounting hardware. Lift engine from vehicle at a 45° angle. To install, reverse removal procedures.

INTAKE MANIFOLD

1) Partially drain radiator and remove air cleaner. Disconnect electrical wires, water hoses and vacuum line from carburetor. Unscrew return valve and disconnect carburetor linkage. Unscrew four attaching nuts and remove carburetor.

2) Disconnect hoses from intake manifold. Remove attaching screws and lift off manifold. To install, reverse removal procedure and use a new gasket.

CYLINDER HEAD

Removal - 1) Drain and remove radiator. Remove air cleaner and valve cover. Remove battery and idler pulley with mounting bracket. Disconnect air conditioning compressor and condenser and place aside with all hoses connected.

2) Remove three-cornered cover and vacuum pump from front of camshaft housing. Disconnect all electrical leads, water hoses and vacuum lines from cylinder head and carburetor.

3) Remove longitudinal regulating linkage and EGR line. Disconnect oil return line at cylinder head. Loosen hose

between water pump and thermostat housing. Disconnect bypass line at water pump.

4) Loosen dipstick guide tube at cylinder head and bend slightly to the side. Disconnect exhaust pipes at manifold and transmission. Remove preheater scoop. Using a screwdriver, force out rocker arm tension springs. Using suitable tool (110 589 04 61 00), remove all rocker arms.

5) Rotate crankshaft until both camshaft timing marks are correctly aligned with crankshaft at TDC on firing stroke. Using suitable holding wrench (116 589 01 01 00), remove both camshaft sprocket bolts.

6) Remove upper slide rail and pull out bearing bolts, using suitable puller (110 589 19 33 00). Remove chain tensioner. Push both camshafts toward rear of engine to separate sprockets and camshafts, using suitable tool (110 589 03 33 00). While supporting sprockets, remove spacer ring (intake) and both spacer sleeves in front of camshaft bearings.

7) Remove sealing plug and pull out bearing bolt, using suitable tool (115 589 19 33 00). Lift up timing chain and pull idler sprocket from camshaft housing. Using same puller, remove slide rail bearing pin and slide rail.

8) Loosen head bolts in reverse of tightening order. Remove two 8mm bolts in chain box with a magnet, do not drop washers into timing cover. Pull up timing chain and force tension rail toward center of engine. Using two men, lift cylinder head vertically from cylinder block.

Installation - 1) Place head gasket on cylinder block. Lay two pieces of wood, ½"x1¾"x9½" long, upright between cylinders one and two and flat between cylinders five and six. Mount cylinder head at an inclined position, so that timing chain and tensioner rail can be installed.

2) Lift cylinder head and carefully remove wooden pieces. Lower head, making sure front dowel pin is engaged. Install head bolts and tighten in three stages. Insert 8 mm bolts in chain box using a greased Allen wrench.

NOTE - After tightening all head bolts, camshaft should be free to turn by hand.

3) Install lower slide rail and idler sprocket. Place spacer on intake camshaft journal. With engine at TDC, install camshaft sprockets with timing marks aligned, using suitable tool (110 589 03 33 00).

NOTE - TDC mark on vibration damper is next to dowel pin.

1973 MERCEDES-BENZ (M110) 6 CYLINDER (Cont.)

4) Place spacers in front camshaft bearing of both camshafts. Install camshaft sprockets bolts, but do not tighten. Install upper slide rail and rigid chain tensioner. Using suitable holder tool (116 589 01 01 00), tighten expansion bolts.

NOTE — If early type camshaft sprocket bolts with two spring washers were installed, replace with new expansion bolts (110 990 02 19) and a single washer (110 990 23 40).

5) Rotate engine two revolutions and recheck camshaft timing marks. Install swing lever and tensioner springs. Install chain tensioner and adjust valve clearances. Retighten head bolts after engine has been warmed to 176°F (water temperature). Tighten by first loosening head bolts a ¼ of a turn, one at a time and tighten in tightening order. Retighten 8mm bolts in chain box.

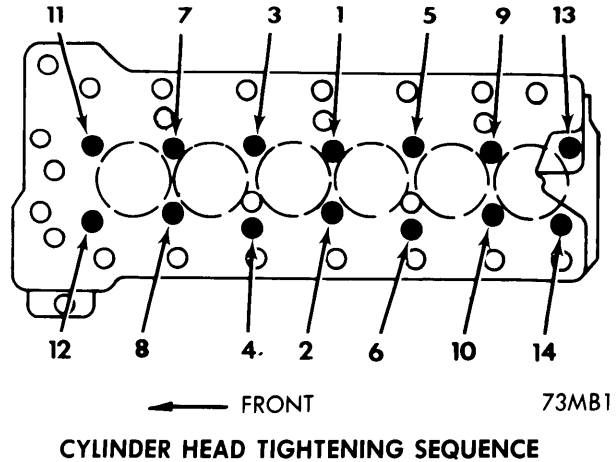

| VALVES | | | | | | | |
|----------------|----------------------------|------------|------------|------------------------|------------------------------|-------------------------|---------------------|
| Engine & Valve | Head Diam. In. (mm) | Face Angle | Seat Angle | Seat Width In. (mm) | Stem Diameter In. (mm) | Stem Clearance In. (mm) | Valve Lift In. (mm) |
| M110 Int. | 1.776-1.784 (45.1-45.3) | 45° | 45° | .071-.098 (1.8-2.5) | .3526-.3531 (8.955-8.970) | .015 (.38) | |
| Exh. | 1.457-1.465 (37.0-37.2) | 45° | 45° | .059-.079 (1.5-2.0) | .4307-.4315 (10.94-10.96) | .039 (.99) | |

VALVE ARRANGEMENT

Right Side — All exhaust.
Left Side — All intake.

VALVE GUIDE SERVICING

- Using a suitable drift, drive valve guide out top of cylinder head. Inspect guide bore in cylinder head, drive new standard guide in until lock ring touches head, if head condition permits.
- If standard valve guide is not tight in head, ream cylinder head and install oversize valve guide. Heat cylinder head to 194°F and chill valve guide. Drive new guide in until lock ring touches head.

Valve Guide Specifications In. (mm)

| Intake | Guide O.D. | Head I.D. |
|------------------|------------------------------|------------------------------|
| Std. (gray) | .5525-.5531 (14.03-14.05) | .5520-.5528 (14.02-14.04) |
| 1st O.S. (red) | .5594-.5602 (14.21-14.23) | .5591-.5598 (14.20-14.22) |
| 2nd O.S. (white) | .5673-.5681 (14.41-14.43) | .5669-.5677 (14.40-14.42) |
| Exhaust | Guide O.D. | Head I.D. |
| Std. (gray) | .5917-.5925 (15.03-15.05) | .5913-.5921 (15.02-15.04) |
| 1st O.S. (red) | .5988-.5996 (15.21-15.23) | .5984-.5992 (15.20-15.22) |
| 2nd O.S. (white) | .6067-.6075 (15.41-15.43) | .6063-.6071 (15.40-15.42) |

VALVE STEM OIL SEALS

With valve springs removed, pull off old seal. Place assembly sleeves over intake valve stems and slide new valve stem seal

over valve stems. Remove assembly sleeve and force seal over end of valve guide with installation mandrel.

| VALVE SPRINGS | | | |
|---------------|----------------------|--|-----------------------------------|
| Engine | Free Length In. (mm) | PRESSURE (LBS.) Lbs. @ In. (kg @ mm) | |
| | | Valve Closed | Valve Open |
| M110 Inner | 1.772 (45) | 24.7-27.3@1.30 (11.2-12.4@33) | 50.3-55.6@.85 (22.8-25.2@21.5) |
| Outer | 1.949 (49.5) | 65.0-71.7@1.65 (29.5-32.5@42) | 185-203@1.20 (84-92@30.5) |

VALVE SPRINGS

- With camshaft housing removed, place piston on TDC of cylinder from which springs are to be removed. Install a compressed air line to spark plug hole to pressurize valves.
- Remove valve thrust pieces. Attach suitable holding rail (110 589 00 62 00) to cylinder head. Lightly tap valve collars to loosen keepers. Install suitable spring compressor and press down on springs. Remove valve keepers and release pressure on springs. Remove inner and outer springs and check for wear or fatigue. To install, reverse removal procedures with close wound coils (color coding) next to cylinder head.

ROCKER ARM & STUD ASSEMBLY

- With a screwdriver, pry out rocker arm tensioner springs. Using crankshaft, rotate engine until heel of cam lobe is next to rocker arm. Using suitable tool (110 589 04 61 00), remove rocker arm.

1973 MERCEDES-BENZ (M110) 6 CYLINDER (Cont.)

2) Unscrew threaded bushing with valve adjusting screw. Lubricate threads of adjusting screw with tallow and check that screw has at least 14.5 ft. lbs. of turning torque in bushing.

3) Install threaded bushing and adjusting screw in cylinder head. Lubricate rocker arm and pivot. Using suitable tool (110 589 04 61 00), install rocker arms and tensioner springs. Readjust valve clearances.

CAUTION — Do not rotate engine by camshaft sprocket bolts. Do not rotate engine in reverse as camshaft sprocket may jump time.

VALVE CLEARANCE ADJUSTMENT

Rotate crankshaft until heel of camshaft lobe is next to rocker arm. Insert a feeler gauge between camshaft and rocker arm. Turn adjusting screw until proper clearance is achieved.

Valve Clearance In. (mm)

Application

Cold

Intake ①.003 (.08)
Exhaust008 (.20)

① — Set valve clearance to .005" (.12 mm) when temperature is constantly below -4°F (-20°C).

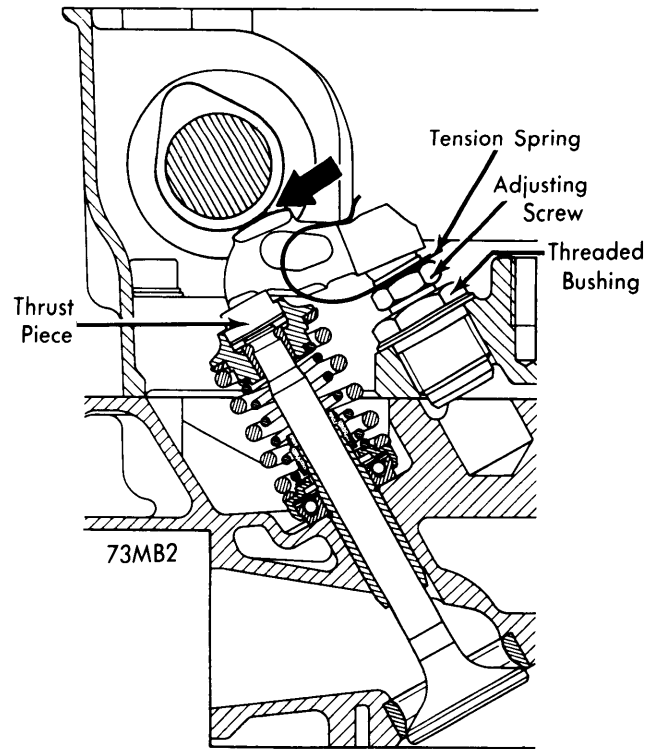

ROCKER ARM & VALVE ASSEMBLY

| PISTONS, PINS, RINGS | | | | | | |
|----------------------|----------------------------|------------------------------------|----------------------------|-------|------------------------|----------------------------|
| Engine | PISTONS | | PINS | | RINGS | |
| | Clearance In. (mm) | Piston Fit In. (mm) | Rod Fit In. (mm) | Rings | End Gap In. (mm) | Side Clearance In. (mm) |
| M110 | .0010-.0014 (.025-.035) | -.0004 to .0001 (-.011 to .002) | .0003-.0007 (.007-.017) | No. 1 | .012-.018 (.30-.45) | .002-.003 (.05-.08) |
| | | | | No. 2 | .012-.018 (.30-.45) | .001-.002 (.03-.06) |
| | | | | Oil | .010-.016 (.25-.40) | .0004-.002 (.01-.04) |

OIL PAN

Removal — Disconnect both front engine mounts. Disconnect engine shock absorbers on right front axle carrier. Attach a lifting sling. Remove front axle, and oil lines from automatic transmission. Loosen oil dipstick guide tube. Drain engine oil and pull off oil return line on oil pan.

Installation — Clean parting surfaces on crankcase and oil pan. Replace rear radial sealing ring in oil pan, working seal into pan with a wooden hammer handle. Cut seal ends so there is .024" protruding. Coat sealing surfaces with sealing compound and install oil pan. To install remaining components, reverse removal procedure.

PISTON & ROD ASSEMBLY

Removal — With oil pan and cylinder head removed, remove rod caps and push piston and rod assembly out top of cylinder. Remove wrist pin locks and push out wrist pins. Clean and inspect all parts.

Installation — 1) Place piston on connecting rod so that arrow faces forward and recess for bearing insert is facing rear of engine. Install piston and rod assembly in cylinder. Install rod cap with code numbers facing rod numbers.

2) Rod bolts should be checked for minimum diameter with a pair of sharp edged calipers. If diameter is less than .283", replace rod bolts. Tighten rod bolts to 36 ft. lbs. and then tighten an additional 100° of rotation.

FITTING PISTONS

Inspect piston and cylinder for wear or damage. Measure piston clearance, if clearance exceeds .004", bore cylinder and fit new pistons.

| Application | Cylinder Bore Specifications | |
|---------------|------------------------------|-----------------|
| | In. (mm) | |
| Std. | 3.3858-3.3867 | (86.000-86.022) |
| 1st O.S. | 3.4055-3.4064 | (86.500-86.522) |
| 2nd O.S. | 3.4252-3.4261 | (87.000-87.022) |

Mercedes-Benz Engines

1973 MERCEDES-BENZ (M110) 6 CYLINDER (Cont.)

| CRANKSHAFT MAIN & CONNECTING ROD BEARINGS | | | | | | | |
|---|----------------------------------|----------------------------|------------------------|------------------------------|----------------------------|------------------------|--------------------|
| Engine | MAIN BEARINGS | | | | CONNECTING ROD BEARINGS | | |
| | Journal Diam. In. (mm) | Clearance In. (mm) | Thrust Bearing | Crankshaft End Play In. (mm) | Journal Diam. In. (mm) | Clearance In. (mm) | Side Play In. (mm) |
| M110 | 2.3604-2.3608 (59.955-59.965) | .0018-.0026 (.045-.065) | .004-.009 (.10-.24) | 1.8882 (47.960) | .0006-.0020 (.015-.050) | .004-.009 (.11-.23) | |

MAIN & CONNECTING ROD BEARINGS

1) Remove connecting rod and main bearing caps. Check all bearing journals for wear, taper or out-of-round. The following table gives maximum dimensions which are permissible without repair or new bearings.

Crankshaft Specifications

| Application | In. (mm) |
|---------------------------------|--------------|
| Out-of-Round | .0002 (.005) |
| Journal Taper | .0004 (.01) |
| Journal Flatness | .0006 (.015) |
| Bearing Bore Out-of-Round | .0004 (.01) |
| Bearing Bore Taper | .0004 (.01) |

2) Bearing inserts for both main and connecting rod journals are color coded. Main bearing inserts with no color are thicker than ones which are blue. Connecting rod inserts with red color are thicker than ones with blue color. Select inserts which will give the mean of clearance range.

Crankshaft Journal Diameters

| Application | Main Bearing In. (mm) | Connecting Rod In. (mm) |
|---------------|----------------------------------|----------------------------------|
| Std. | 2.3604-2.3608 (59.955-59.965) | 1.8880-1.8884 (47.955-47.965) |
| 1st U.S. | 2.3506-2.3510 (59.705-59.715) | 1.8781-1.8785 (47.705-47.715) |
| 2nd U.S. | 2.3407-2.3411 (59.455-59.465) | 1.8683-1.8687 (47.455-47.465) |
| 3rd U.S. | 2.3309-2.3313 (59.205-59.215) | 1.8585-1.8589 (47.205-47.215) |
| 4th U.S. | 2.3211-2.3215 (58.955-58.965) | 1.8486-1.8490 (46.955-46.965) |

Bearing Insert Wall Thickness

| Application | Main Bearing In. (mm) | Connecting Rod In. (mm) |
|---------------|-----------------------|-------------------------|
| Std. | .1378 (3.50) | .0713 (1.81) |
| 1st U.S. | .1429 (3.63) | .0764 (1.94) |
| 2nd U.S. | .1476 (3.75) | .0811 (2.06) |
| 3rd U.S. | .1528 (3.88) | .0858 (2.18) |
| 4th U.S. | .1575 (4.00) | .0909 (2.31) |

THRUST BEARING ALIGNMENT

Install number three main bearing and measure clearance between bearing and crankshaft sides. If clearance is excessive, install new bearing. New bearings are supplied in oversize widths and must be lapped on non-thrust side to achieve proper clearance. Lap only side away from flywheel.

REAR MAIN BEARING OIL SEAL

Press pieces of seal into cylinder block and oil pan with a wooden hammer handle. Cut ends of seal so they protrude

.024" above parting surfaces. Reassemble engine and check for oil leaks.

FRONT COVER OIL SEAL

1) Remove pulley, vibration damper and balancing disc. Carefully pry oil seal from cover with a screwdriver. If spacer

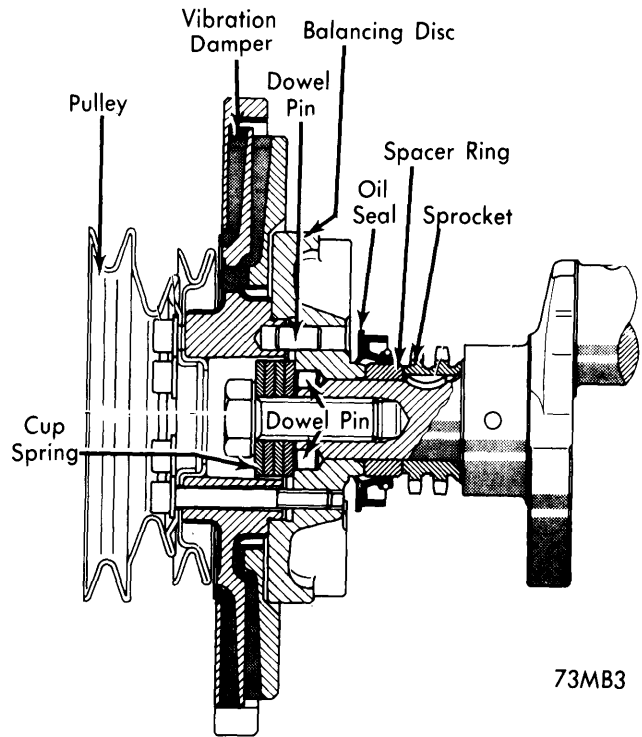

73MB3

VIBRATION DAMPER INSTALLATION

| CAMSHAFT | | | |
|----------|--------------------------------|--------------------------|--------------------|
| Engine | Journal Diam. In. (mm) | Clearance In. (mm) ① | Lobe Lift In. (mm) |
| M110 | | | |
| a | .9441-.9445 (23.98-23.99) | .0024-.0047 (.06-.12) | |
| b | 1.9654-1.9661 (49.92-49.94) | .0039-.0055 (.10-.14) | |
| c | 1.9657-1.9665 (49.93-49.95) | .0020-.0035 (.05-.09) | |
| d | 2.0244-2.0252 (51.42-51.44) | .0024-.0039 (.06-.10) | |
| e | 2.0835-2.0842 (52.92-52.94) | .0024-.0039 (.06-.10) | |
| f | 2.1228-2.1236 (53.92-53.94) | .0024-.0039 (.06-.10) | |

① — End play is .007-.017" (.17-.44 mm).

1973 MERCEDES-BENZ (M110) 6 CYLINDER (Cont.)

ring on crankshaft is worn, using suitable puller (115 589 15 33 00), remove and replace ring.

2) Slightly lubricate new seal and press into cover, using suitable tool (110 589 07 61 00). Seal must be perfectly square or leaks will occur. Reinstall pulley, vibration damper and balancing disc.

TIMING CHAIN

1) Remove spark plugs and camshaft cover. Remove rocker arm of right-hand exhaust valve. Remove chain tensioner and install a rigid chain tensioner.

2) Cover chain box with a rag, using a chain breaker, separate chain. Join ends of new and old chains together with a master link. Rotate crankshaft in direction of rotation and pull old chain out of engine. Use care that chain does not jump a tooth on sprockets.

3) Join ends of new chain. Rotate crankshaft and check timing marks. Replace rigid chain tensioner with normal chain tensioner. Install rocker arm and adjust valve clearance. Install camshaft cover and spark plugs.

CAMSHAFT & CAMSHAFT HOUSING

Removal - 1) Remove battery and A.I.R. pump. Disconnect air conditioning compressor and set aside with hoses connected. Drain radiator and remove hose between radiator and engine. Remove camshaft cover.

2) Remove camshaft sprocket covers from front of housing. Pry all rocker arm tension springs from rocker arms. Using a suitable tool (110 589 04 61 00), remove all rocker arms.

CAUTION - Do not turn engine by camshaft bolts. Do not rotate crankshaft in reverse.

3) Using suitable holding tool (116 589 01 01 00), remove right-hand camshaft sprocket bolt. Set number one piston to TDC on firing stroke with both camshaft timing marks aligned. Remove chain tensioner.

4) Remove slide rail in camshaft housing, using suitable puller (115 589 19 33 00). Remove rear right-hand camshaft cover. Push camshaft to the rear, using suitable tool (110 589 03 33 00), while holding camshaft sprocket in place. Remove sprocket and slide camshaft back in place.

5) Remove head bolts, shown in illustration, in reverse of tightening sequence. Do not remove bolts marked with an "x" in illustration. Remove camshaft housing and camshafts.

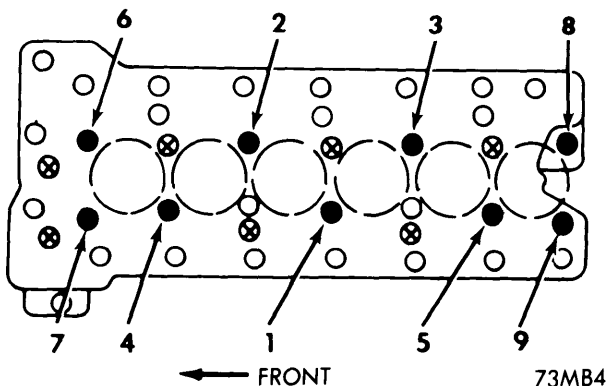

CAMSHAFT HOUSING TIGHTENING SEQUENCE

6) Remove left-hand camshaft sprocket in same manner as right-hand sprocket. Remove spacer ring at intake camshaft and slide both camshafts out rear of housing.

Installation - Install steel gasket on cylinder head without sealing compound. Place camshaft housing on head. Oil head bolts and tighten in two steps shown in illustration. One at a time, loosen slightly and retighten five lower head bolts. Tighten 8 mm bolts from center working outward. Install remaining components in reverse of removal procedures.

NOTE - If early type camshaft sprocket bolts with two spring washers were installed, replace with new expansion bolts (110 990 02 19) and a single washer (110 990 23 40).

CAMSHAFT BEARINGS

If camshaft bearing journals are worn, damaged or have excessive clearance in camshaft housing bearings, camshaft journals may be ground undersize and a repair housing installed. Front bearing journal "a" (see illustration) is not ground and remains standard.

Camshaft Bearing Specifications In. (mm)

| Application | Bearing I.D. | Journal O.D. |
|------------------------|--------------------------------|--------------------------------|
| Standard | | |
| A [ⓐ] | 1.4961-1.4968 (38.00-38.02) | .9441-.9445 (23.98-23.99) |
| B | 1.9705-1.9713 (50.05-50.07) | 1.9654-1.9661 (49.92-49.94) |
| C | 1.9685-1.9693 (50.00-50.02) | 1.9657-1.9665 (49.93-49.95) |
| D | 2.0276-2.0283 (51.50-51.52) | 2.0244-2.0252 (51.42-51.44) |
| E | 2.0866-2.0874 (53.00-53.02) | 2.0835-2.0842 (52.92-52.94) |
| F | 2.1260-2.1268 (54.00-54.02) | 2.1228-2.1236 (53.92-53.94) |
| Repair Stage I | | |
| B | 1.9606-1.9614 (49.80-49.82) | 1.9559-1.9567 (49.68-49.70) |
| C | 1.9587-1.9594 (49.75-49.77) | 1.9559-1.9567 (49.68-49.70) |
| D | 2.0177-2.0185 (51.25-51.27) | 2.0146-2.0154 (51.17-51.19) |
| E | 2.0768-2.0776 (52.75-52.77) | 2.0736-2.0744 (52.67-52.69) |
| F | 2.1161-2.1169 (53.75-53.77) | 2.1130-2.1138 (53.67-53.69) |
| Repair Stage II | | |
| B | 1.9508-1.9516 (49.55-49.57) | 1.9461-1.9468 (49.43-49.45) |
| C | 1.9488-1.9496 (49.50-49.52) | 1.9461-1.9468 (49.43-49.45) |
| D | 2.0079-2.0087 (51.00-51.02) | 2.0047-2.0055 (50.92-50.94) |
| E | 2.0669-2.0677 (52.50-52.52) | 2.0638-2.0646 (52.42-52.44) |
| F | 2.1063-2.1071 (53.50-53.52) | 2.1031-2.1039 (53.42-53.44) |

ⓐ - "A" bearing location is not changed from standard dimension.

Mercedes-Benz Engines

1973 MERCEDES-BENZ (M110) 6 CYLINDER (Cont.)

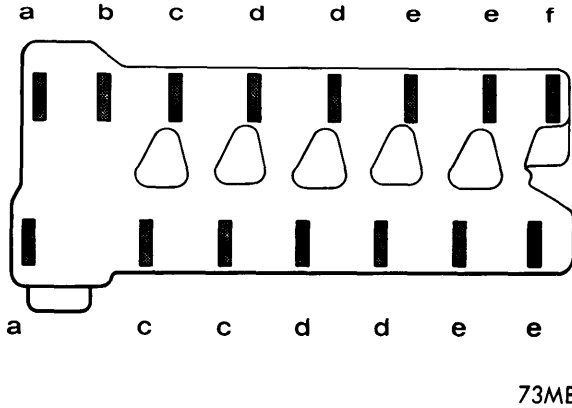

CAMSHAFT BEARING IDENTIFICATION

NOTE — Some balance discs have two "O" degree marks. TDC is next to a dowel pin.

CAUTION — Do not turn engine by camshaft sprocket bolts. Do not rotate crankshaft in reverse or timing chain may jump a tooth on camshaft sprockets.

Offset Woodruff Keys

| Part No. | Offset In. (mm) | Correction |
|---------------|--------------------|------------|
| 621 991 04 67 | .028 (0.7) | 4° |
| 621 991 02 67 | .035 (0.9) | 6.5° |
| 621 991 01 67 | .043 (1.1) | 8° |
| 621 991 00 67 | .051 (1.3) | 10° |

| VALVE TIMING | | | | |
|--------------|----------------|-----------------|----------------|-----------------|
| Engine | INTAKE | | EXHAUST | |
| | Open (BTDC) | Close (ABDC) | Open (BBDC) | Close (ATDC) |
| M110Ⓞ | 11° | 15° | 22° | 14° |

Ⓞ — With .079" (2.0 mm) valve lift.

VALVE TIMING

Rotate crankshaft until number one piston is at TDC on firing stroke. Both camshaft timing marks should be aligned with marks on camshaft housing. Offset woodruff keys are available to make corrections to timing. Remember that camshaft sprockets rotate in opposite directions, they rotate toward each other.



CAMSHAFT TIMING MARKS

ENGINE OILING

Crankcase Capacity — 7 qts. (including filter).

Oil Filter — 1.5 pts. (Full-flow).

Normal Oil Pressure — 42.6 psi at 3,000 RPM.

Pressure Regulator Valve — Nonadjustable.

ENGINE OILING SYSTEM

Oil is drawn from the oil pan by a gear type oil pump and pressure fed through a full-flow oil filter to crankshaft main bearings. Passages drilled in crankshaft carry oil to connecting

rod bearings. A passageway drilled longitudinally through the connecting rod carries oil from connecting rod bearing to wrist pin bushing. A further passageway carries oil to intermediate shaft, oil pump, and distributor drive gears. This passageway also lubricates camshaft bearings, cam lobes, rocker arms, idler sprocket, and chain tensioner.

OIL PUMP

Remove fuel pump and lower half of oil pan. Remove screws from crankcase and main bearing cap. Pull out oil pump. Disassemble, clean and inspect oil pump. To install, reverse removal procedure.

ENGINE COOLING

Cooling System Capacity — 14.8 qts.

Thermostat — Opens 188.6°F.

WATER PUMP

Drain radiator and disconnect water hoses. Loosen radiator shell and remove radiator. Remove fan and fan clutch (store in upright position). Remove all drive belts. Remove six Allen screws attaching pulley and vibration damper. Withdraw pulley and damper. Remove water pump. To install, reverse removal procedure.

1973 MERCEDES-BENZ (M110) 6 CYLINDER (Cont.)

TIGHTENING SPECIFICATIONS

| Application | Ft. Lbs. (mkg) |
|-----------------------|----------------|
| Main Bearing | 58 (8.0) |
| Connecting Rods | ①36 (5.0) |
| Balancing Disc..... | 325 (45) |
| Camshaft Cover | 18 (2.5) |
| Cylinder Head | |
| 12 mm Bolts | ②65 (9.0) |
| 8 mm Bolts | 18 (2.5) |
| Camshaft Bolts..... | 58 (8.0) |
| Oil Pump..... | 22 (3.0) |

- ① — Tighten bolts to 36 ft. lbs. (5.0 mkg) and then turn bolts an additional 100°.
- ② — Tighten in steps: 1st step — 29 ft. lbs. (4.0 mkg), 2nd step — 43 ft. lbs. (6.0 mkg), 3rd step — 65 ft. lbs. (9.0 mkg).

ENGINE NOTES

1973 MERCEDES-BENZ M110 ENGINE — ENGINE CRANKING CAUTION — It is to be especially noted that reverse cranking (which may occur when adjusting valve clearance) should NOT BE ALLOWED under any circumstances. Due to a special timing chain support, there is a possibility that the timing chain on the intake camshaft gear may jump. This will change valve timing and can substantially damage the engine when started.

1973 MERCEDES-BENZ — EXHAUST VALVE WARNING — Almost all Mercedes-Benz passenger vehicle engines are equipped with sodium filled exhaust valves. Under no circumstances should these exhaust valves be cut or melted down for other purposes (punches, chisels, etc.), since there is a danger of explosion when the sodium is exposed to the atmosphere.

1973 MERCEDES-BENZ — IMPROVED OIL PUMP DRIVE SHAFT — From March, 1973, high pressure oil pumps with improved drive shafts have been installed. These pumps are marked with a yellow dot on the neck of the pump cover. When repairing these pumps, ensure the proper kit is obtained. Installation of the new drive shaft will require a special assembly sleeve (Part No. 700 589 00 46 00) and a special installer (Part No. 700 589 01 46 00).