

1973 HONDA CIVIC 4 CYLINDER

GENERAL SPECIFICATIONS										
Year	Displ.		Carburetor	HP at RPM	Torque (Ft. Lbs. at RPM)	Compr. Ratio	Bore		Stroke	
	cu. ins.	cc					in.	mm	in.	mm
1973	71.39	1170	1x2-Bbl.	8.3-1	2.76	70	2.99	76

ENGINE IDENTIFICATION

Engine serial number is located on right rear side of engine. Serial number is preceded by letters EBI.

ENGINE REMOVAL

1) Raise front of vehicle and support on floor stands. Remove front wheels, grille, turn signal lights, hood and air cleaner. Drain transmission and radiator.

2) Disconnect battery ground cable at battery and transmission. Remove fuel vapor storage canister hose at carburetor. Disconnect fuel line at fuel pump, lower radiator hose at water pump and upper hose at thermostat cover.

3) Disconnect following control cables and wires from engine; throttle and choke cables at carburetor, clutch cable at release arm, coil wires at distributor, starter positive cable at starter and starter solenoid wire.

4) Disconnect back-up light switch, transmission controlled spark (TCS) switch wires, speedometer cable, tachometer cable (if equipped) and alternator harness.

NOTE — It is not necessary to remove entire cable holder of speedometer cable. Remove end boot, cable retaining clip and pull cable from holder. If cable holder bolt is removed, do not rotate holder more than 30° in either direction to prevent dowel pin from falling into transmission.

5) Remove wires from both thermo-switches on intake manifold. Disconnect fan wire connector and radiator thermo-switch wires. Disconnect heater hose by removing "H" connector from two hoses in firewall.

6) Remove engine torque rod, starter and radiator. Remove exhaust pipe clamp, flange nuts and lower exhaust pipe.

7) Disconnect left and right lower control arm ball joints at knuckles, using suitable ball joint tool (07941-6340000). Hold brake disc in one o'clock (right-hand), and eleven o'clock (left-hand) position and pull both drive shafts out of differential housing.

8) Using a suitable pin driver, remove gearshift rod pin (8 mm) at transmission. Disconnect gearshift extension at engine.

NOTE — Do not disconnect shift lever end of gearshift rod and extension.

9) Install suitable engine sling and lift engine enough to take load off mounts. Remove two center mount nuts. Lower center beam. Remove left engine mount and lift engine from vehicle. To install, reverse removal procedures.

INTAKE MANIFOLD

1) Drain radiator and disconnect upper radiator hose at thermostat cover. Remove air cleaner and disconnect tube from vapor canister at canister. Disconnect throttle and choke cables.

2) Disconnect heater hose at manifold, wires from both thermo-switches on manifold and fuel line at fuel pump. Remove manifold attaching nuts and withdraw intake manifold from studs. To install, reverse removal procedure.

CYLINDER HEAD

1) Remove turn signal lights, grille and hood. Drain radiator and disconnect upper radiator hose at thermostat cover. Remove air cleaner.

2) Disconnect tube from vapor canister at canister, throttle cable, choke cable, heater hose at intake manifold, wires from both thermo-switches on intake manifold and fuel line at pump inlet port.

3) Disconnect engine torque rod, exhaust pipe at manifold. Remove valve cover and upper timing belt cover. Rotate crankshaft until number one piston is at TDC.

4) Loosen (do not remove) timing belt adjusting bolt and pivot bolt. Remove camshaft pulley bolt. Do not let Woodruff key fall inside timing cover. Remove pulley, using suitable puller (07935-6110000).

5) Remove fuel pump and distributor. Remove oil pump gear holder, pump gear and shaft. Loosen and remove head bolts, starting from outside in a criss-cross pattern. Remove cylinder head complete with intake and exhaust manifolds.

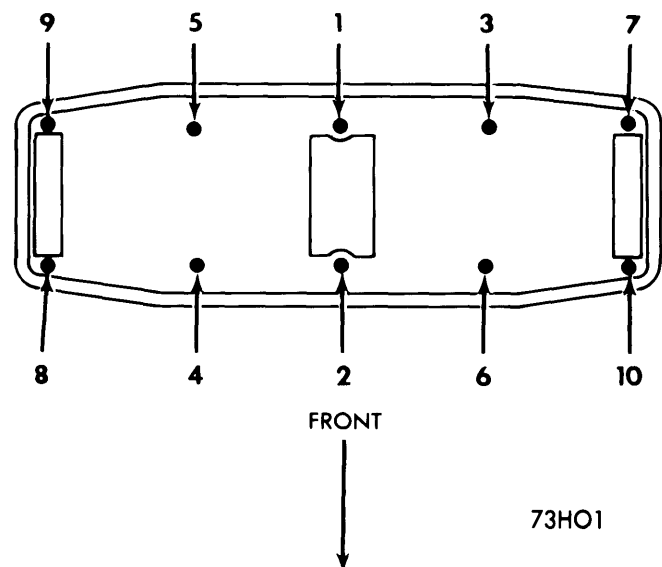

CYLINDER HEAD TIGHTENING SEQUENCE

Honda Engines

1973 HONDA CIVIC 4 CYLINDER (Cont.)

VALVES							
Engine & Valve	Head Diam. In. (mm)	Face Angle	Seat Angle	Seat Width In. (mm)	Stem Diameter In. (mm)	Stem Clearance In. (mm)	Valve Lift In. (mm)
1170 cc Intake	45°	45°	.0551 (1.4)	.2591-.2594 (6.580-6.590)	.0004-.0016 (.01-.04)
Exhaust	45°	45°	.0551 (1.4)	.2579-.2583 (6.55-6.56)	.0020-.0031 (.05-.08)

VALVE ARRANGEMENT

Front Side — All Exhaust.
Rear Side — All Intake.

VALVE GUIDE SERVICING

Using a suitable drift, drive valve guides out top side of head. Install new guides and ream guides to .2602-.2610" using a suitable reamer (07984-6110000). Install new intake valve guide seals.

VALVE SPRINGS			
Engine & Spring	Free Length In. (mm)	PRESSURE Lbs. @ In. (kg @ mm)	
		Valve Closed	Valve Open
1170 cc Inner	1.6535 (42.0)
Outer	1.5728 (39.95)

VALVE SPRINGS

Using suitable valve spring compressor, remove valve keepers, collars and springs. Check valve springs for squareness, they

should be within 2° of true. Measure free length of springs, minimum length is 1.6535" (inner) and 1.5728" (outer).

ROCKER ARM ASSEMBLY

Removal — Loosen rocker arm shaft bolts in criss-cross pattern starting with end supports. Starting with number four cylinder support, pull out 4 mm pin and remove supports, rocker collars, rocker arms and springs. Retain components in proper order for reassembly.

Installation — When reinstalling rocker arms, place intake rocker arm shaft so that notch faces rear of vehicle and oil holes are on the bottom. Exhaust rocker arm shaft is installed with oil holes facing down and dowel pin hole on left-hand side of engine. After assembly check rocker arms for freedom of movement.

VALVE CLEARANCE ADJUSTMENT

1) Rotate engine until number one piston is at TDC on compression stroke, check intake valves of number one and two cylinders and exhaust valves of number one and three cylinders. Rotate crankshaft 360° and check intake valves of number three and four cylinders and exhaust valves of number two and four cylinders.

2) Using a feeler gauge between rocker arm and valve stem, loosen lock nut and adjust valve clearance. Tighten lock nut and recheck valve clearance. Valve clearance is .005-.007" cold.

PISTONS, PINS, RINGS						
Engine	PISTONS	PINS		RINGS		
	Clearance In. (mm)	Piston Fit In. (mm)	Rod Fit In. (mm)	Rings	End Gap In. (mm)	Side Clearance In. (mm)
1170 cc	.0012-.0039 (.03-.10)	.0004-.0009 (.010-.022)	⊙.0006-.0015 (.0160-.0390)	No.1	.008-.016	.0009-.0018
				(.2-.4)	(.022-.045)
				No.2	.008-.016	.0009-.0018
				(.2-.4)	(.022-.045)
				No.3	.008-.035
				(.2-.9)

⊙ — Interference fit.

OIL PAN

1) Raise front of vehicle and support with floor stands. Attach a hoist to clutch cable bracket on transmission and raise just enough to take load off center mount.

2) Remove center beam and lower engine mount. Loosen and remove oil pan bolts in a criss-cross pattern, starting from outside bolts. Tap corners lightly with a mallet to break seal and remove oil pan.

PISTON & ROD ASSEMBLY

1) With oil pan and cylinder head removed, ream any ridge from top of cylinders. Mark piston and rod assemblies for proper reinstallation. Remove rod caps and push piston and rod assemblies out top of cylinder with a hammer handle.

2) Assemble piston and connecting rod with piston front mark and connecting rod oil jet hole on same side and facing intake

1973 HONDA CIVIC 4 CYLINDER (Cont.)

manifold. Using a ring compressor, install piston and rod assemblies in proper cylinder.

FITTING PISTONS

1) Check cylinder for wear and taper. Measure piston-to-cylinder clearance, replace pistons as necessary. Pistons are available in four oversizes, determine size required and bore cylinder to proper clearance. Piston crowns are marked as to piston size, 25, 50, 75 and 100.

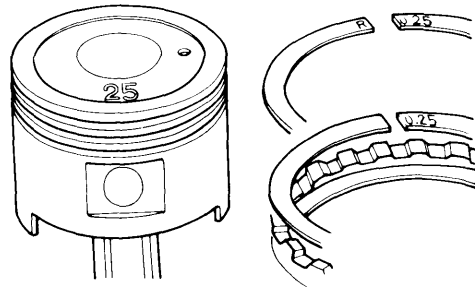

73H02

PISTON & RING SIZE MARK LOCATIONS

Piston Specifications

Mark	Oversize (mm)	Oversize (In.)
25.....	.25.....	.010
50.....	.50.....	.020
75.....	.75.....	.030
100.....	1.00.....	.040

2) Install three piece oil ring on piston with end gaps of rails and spacer staggered approximately 3/4" apart. Install all rings with their size markings facing upward. Position ring end gaps 120° apart with no end gap in line with piston pin or thrust face of piston.

PISTON PINS

Using a press and suitable tool (07973-6340000), press piston pin out of piston and connecting rod. Install new pin by placing pilot through piston and connecting rod. Lightly oil piston pin and place piston, rod, pin and ram on the base. Press in pin until it is centered in connecting rod.

CRANKSHAFT MAIN & CONNECTING ROD BEARINGS

Engine	MAIN BEARINGS				CONNECTING ROD BEARINGS		
	Journal Diam. In. (mm)	Clearance In. (mm)	Thrust Bearing	Crankshaft End Play In. (mm)	Journal Diam. In. (mm)	Clearance In. (mm)	Side Play In. (mm)
1170 cc	1.9673-1.9685 (49.97-50.0)	.0009-.0017 (.024-.042)	No.20039-.0138 (.10-.35)	1.5736-1.5748 (39.97-40.0)	.0008-.0015 (.020-.038)	.0059-.0118 (.15-.30)

MAIN & CONNECTING ROD BEARINGS

1) Prior to disassembly, mark main and connecting rod bearing caps for reassembly to their original locations. Measure crankshaft for bend, out-of-round or taper. No attempt to regrind crankshaft is to be made as bearing journals are specially heat-treated.

2) Using Plastigage method, determine bearing clearances. If bearing replacement is necessary use following procedure to determine bearing size required.

3) Referring to illustration, note that all letters stamped on crankshaft counterweight pads apply to connecting rods and all numbers apply to main bearing journals. Both connecting rods and main bearing journals have mating numbers (stamped on connecting rod) or letters (stamped on block) which when paired are used to determine color of bearing insert to be used, see following tables:

Main Bearing Journals (In.)

Crankcase Counterbore Dia. 2.1259"	A	B	C	D
	Journal Dia. 1.9685"	0 to +.0002	+.0002 to +.0005	+.012 to +.018
1 0 to -.0002	Red -.0001 to -.0002	Pink +.00004 to -.0001	Yellow +.0002 to +.00004	Green +.0003 to +.0002
2 -.0002 to -.0005	Pink +.00004 to -.0001	Yellow +.0002 to +.00004	Green +.0003 to +.0002	Brown +.0004 to +.0003
3 -.0005 to -.0007	Yellow +.0002 to +.00004	Green +.0003 to +.0002	Brown +.0004 to +.0003	Black +.0005 to +.0004
4 -.0007 to -.0009	Green +.0003 to +.0002	Brown +.0004 to +.0003	Black +.0005 to +.0004	Blue +.0006 to +.0005

Honda Engines

1973 HONDA CIVIC 4 CYLINDER (Cont.)

Connecting Rod Bearing Journals (In.)				
Connecting Rod Dia. 1.6929"	Crankshaft Journal Dia. 1.5748"			
	1 0 to +.0002	2 +.0002 to +.0005	3 +.0005 to +.0007	4 +.0007 to +.0009
A 0 to -.0002	Red -.0002 to -.0003	Pink -.0001 to -.0002	Yellow +.00004 to -.0001	Green +.0002 to +.00004
B -.0002 to -.0005	Pink -.0001 to -.0002	Yellow +.00004 to -.0001	Green +.0002 to +.00004	Brown +.0003 to +.0002
C -.0005 to -.0007	Yellow +.00004 to -.0001	Green +.0002 to +.00004	Brown +.0003 to +.0002	Black +.0004 to +.0003
D .0007 to -.0009	Green +.0002 to +.00004	Brown +.0003 to +.0002	Black +.0004 to +.0003	Blue +.0005 to +.0004

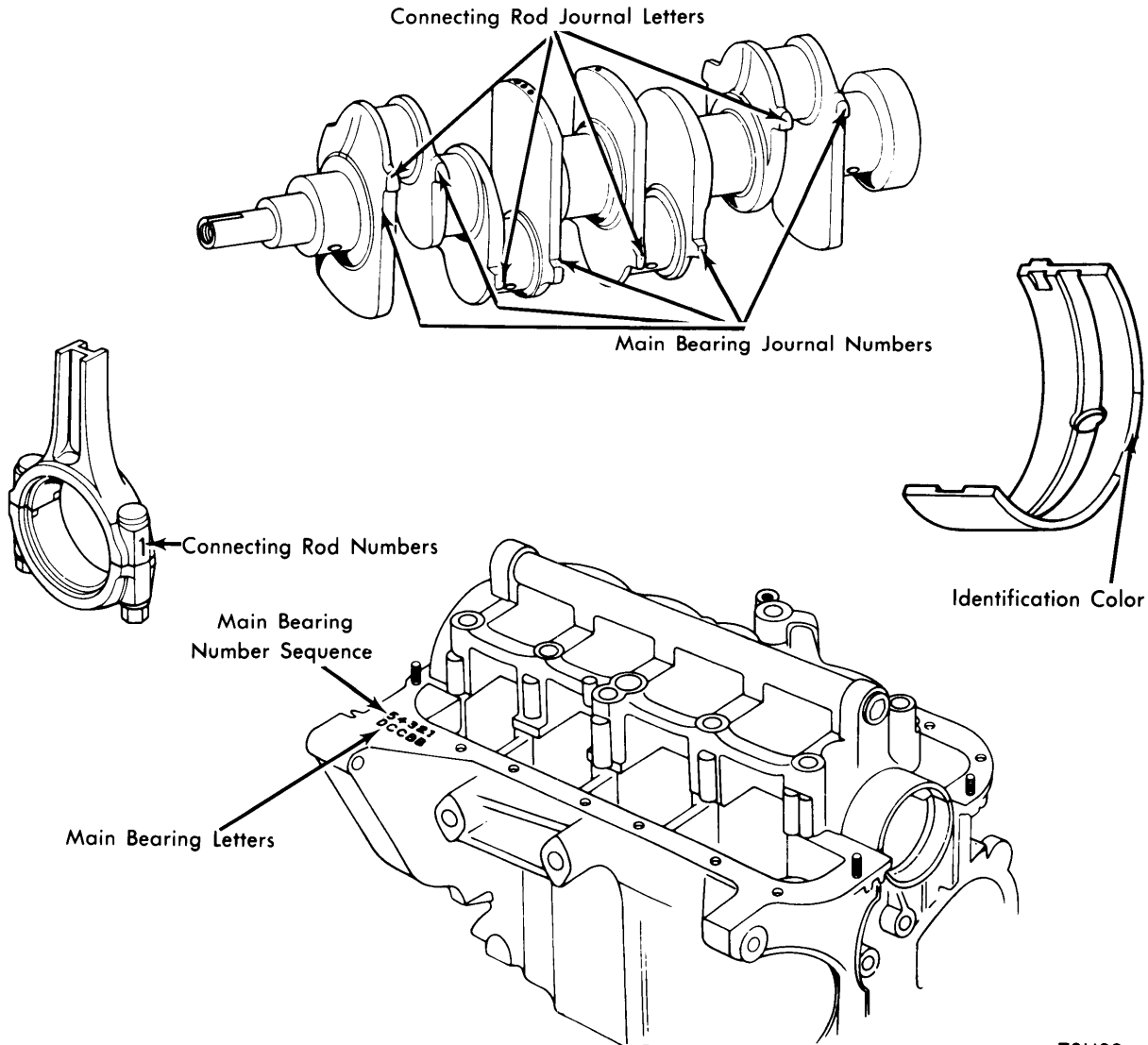

CRANKSHAFT & CONNECTING ROD BEARING IDENTIFICATION

73H03

1973 HONDA CIVIC 4 CYLINDER (Cont.)

THRUST BEARING ALIGNMENT

Measure thrust bearing clearance and replace thrust washers if necessary. Install thrust washers with oil grooves facing toward crankshaft.

CAMSHAFT			
Engine	Journal Diam. In. (mm)	Clearance In. (mm)	Lobe Lift In. (mm)
1170 cc0020-.0035 (.05-.09)

① — End Play is .0197" (.5 mm) maximum.

TIMING BELT

- 1) Remove water pump drive belt, water pump pulley and crankshaft pulley. Remove upper timing belt cover from cylinder head.
- 2) Remove lower timing belt cover from engine block. Loosen (do not remove) timing belt adjusting and pivot bolts. Slide belt off pulleys. To install, reverse removal procedure using care not to excessively bend or twist timing belt. Do not expose belt to engine oil as this will cause belt rubber to swell. Install belt in same direction of rotation to prevent premature wear or failure.

CAMSHAFT

- 1) With cylinder head removed, loosen rocker shaft support bolts in a criss-cross pattern beginning with outside support. Lift rocker shaft assembly from head. Remove camshaft and right-hand seal or tachometer drive body (if equipped).
- 2) Inspect camshaft and cylinder head bearing surfaces for wear or damage. Check camshaft runout, maximum runout permitted is .002". Measure cam lobe height of intake (1.4477-1.4363") and exhaust (1.4429-1.4311"). Maximum lobe wear is .0118".
- 3) Oil camshaft bearing journals. Install camshaft and seal or tachometer drive body (if equipped). Loosen rocker arm adjusting screws, and apply silicone seal to mating surfaces on end camshaft supports and cylinder head. Install rocker arm assembly and tighten support bolts in reverse of removal.

Engine	VALVE TIMING			
	INTAKE		EXHAUST	
	Open (BTDC)	Close (ABDC)	Open (BBDC)	Close (ATDC)
1170cc

VALVE TIMING

Rotate crankshaft pulley until TDC mark is aligned with index mark on timing belt cover. Rotate camshaft pulley until Woodruff key is facing up and timing marks on pulley are parallel with top of cylinder head. Without disturbing pulley position, slide on timing belt. Rotate engine a quarter of a revolution and tighten adjusting bolt, then pivot bolt. Do not apply pressure to timing belt, use only tension of adjusting spring.

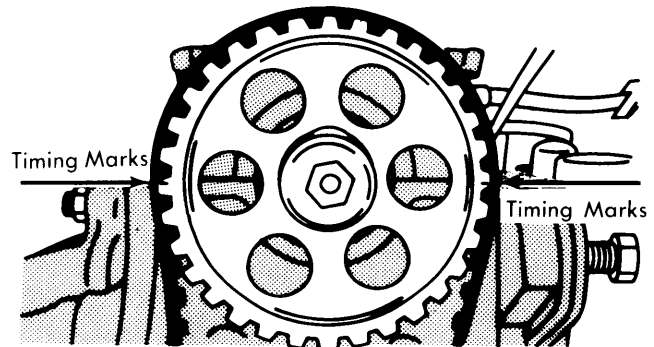

73H04

CAMSHAFT TIMING MARKS

ENGINE OILING

Crankcase Capacity — 3.2 qts.

Oil Filter — Disposable with built-in by-pass valve.

Normal Oil Pressure — 48-58 psi, 21 psi minimum at idle.

Pressure Regulator Valve — Non-adjustable.

ENGINE OILING SYSTEM

A trochoid type oil pump draws oil from oil pan and delivers it under pressure through main bearing cradle to main and connecting rod bearings. Oil passes through rods to an oil jet which lubricates pistons and cylinder walls. An oil passage carries oil to camshaft bearings and rocker arms. Oil mist lubricates valve stems.

OIL PUMP

- 1) Remove oil pan, oil passage block and oil pump assembly. Pull oil relief valve cotter pin and remove seat, spring and valve.

- 2) Remove two pump body bolts and disassemble pump. Inspect pump for wear or damage. Measure pump operating clearances. Reassemble pump and place strainer in container of engine oil. Rotate pump with a screwdriver and check that oil comes out of delivery side. Place finger over hole and see if pressure develops as pump is turned.

Oil Pump Specifications

Application	Std. Clearance In. (mm)	Service Limit In. (mm)
Inner-to-Outer Rotor0059 (.15)	.0079 (.2)
Rotor-to-Body0012-.0039 (.03-.10)	.0059 (.15)
Rotor Side-to-Body0039-.0071 (.1-.18)	.0079 (.2)

Honda Engines

1973 HONDA CIVIC 4 CYLINDER (Cont.)

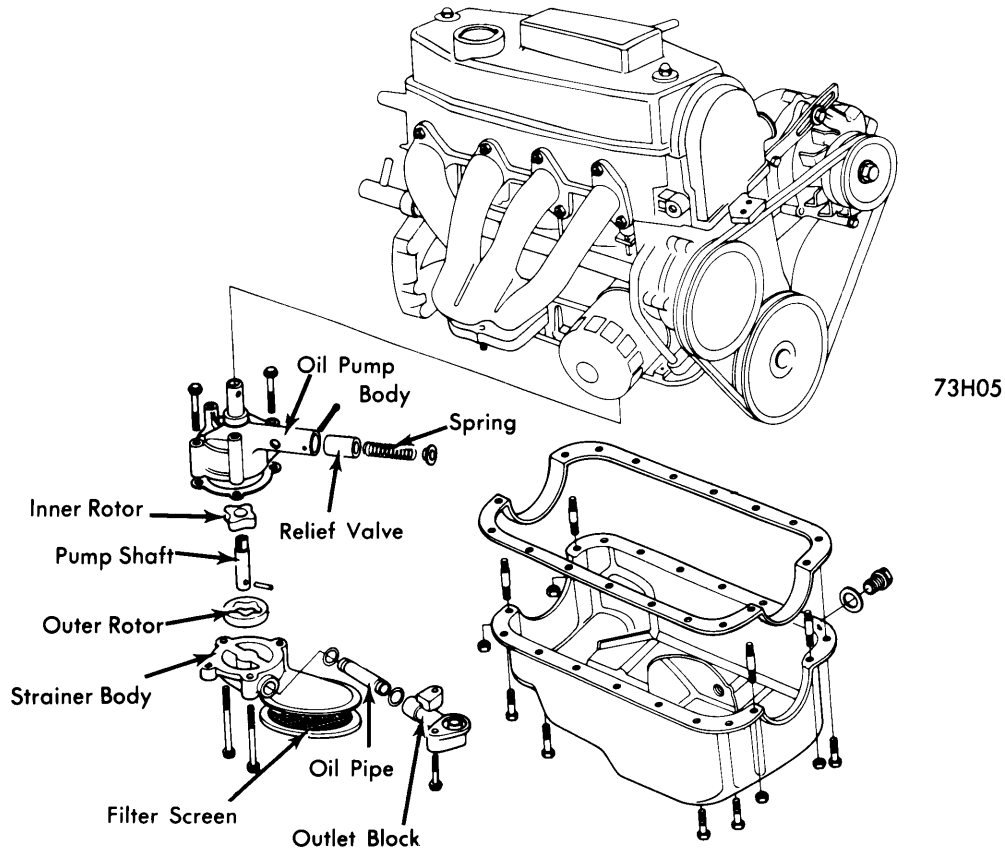

OIL PUMP & PAN ASSEMBLY

ENGINE COOLING

Thermostat - Opens 178-183°F, fully open 203°F.

Thermo-switch - Switch "ON" 191-197°F, "OFF" 182-188°F.

Cooling System Capacity - 4.2 qts.

WATER PUMP

Removal - Drain radiator and loosen alternator adjusting bolts. Push alternator toward engine and remove drive belt. Remove pump and "O" ring seal.

Installation - 1) Reinstall water pump. Loosen cooling system bleed valve located on intake manifold (see illustration). Fill radiator with coolant. When air bubbles no longer appear in coolant draining from bleed valve, close valve.

2) Start engine and place heater temperature control lever in high position. Run engine approximately ten minutes. Again bleed system until there are no air bubbles in coolant draining from bleed valve. Refill radiator.

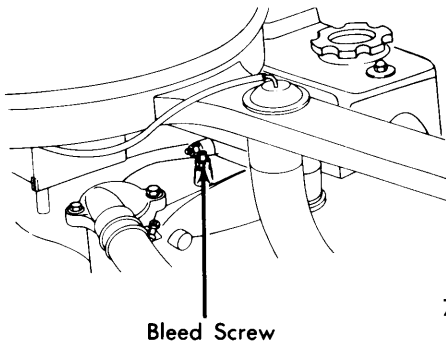

COOLANT BLEED VALVE

TIGHTENING SPECIFICATIONS

Application	Ft. Lbs. (mkg)
Main Bearing Cap.....	27-31 (3.7-4.3)
Connecting Rod Cap.....	18-21 (2.5-2.9)
Camshaft Support.....	13-16 (1.8-2.2)
Flywheel.....	34-38 (4.7-5.3)
Cylinder Head Bolt	
Up to EBI-1019949.....	30-35 (4.2-4.8)
From EBI-109950.....	37-42 (5.1-5.9)
Crankshaft Pulley.....	34-38 (4.7-5.3)
Timing Belt Pulley.....	18-25 (2.5-3.5)
Intake & Exhaust Manifolds.....	13-17 (1.8-2.4)