

1972-73 CAPRI 2600 CC V6

GENERAL SPECIFICATIONS										
Year	Displ.		Carburetor	HP at RPM	Torque (Ft. Lbs. at RPM)	Compr. Ratio	Bore		Stroke	
	cu. ins.	cc					in.	mm	in.	mm
1972-73	155.7	2600	2-Bbl.	8.2-1	3.545	90.043	2.630	66.802

ENGINE IDENTIFICATION

The second series of digits of vehicle identification plate, located on top of right front fender apron, indicates engine type.

Capri Engine

2600 cc..... UX

Engine Code

ENGINE REMOVAL

- 1) Disconnect battery, drain cooling system and remove hood.
- 2) Remove air cleaner and intake duct assembly.
- 3) Disconnect upper and lower hoses at radiator.
- 4) Remove fan shroud and radiator.
- 5) Remove alternator and bracket and position out of the way. Disconnect alternator ground wire and all other ground wires from engine block.
- 6) Disconnect heater hoses at block and water pump.
- 7) Disconnect fuel line at fuel pump. Plug fuel tank line.
- 8) Disconnect accelerator cable or linkage at carburetor and intake manifold. Disconnect transmission downshift linkage, if so equipped.
- 9) Disconnect wire loom at ignition coil. Disconnect brake booster line.
- 10) Raise vehicle and place on safety stands.
- 11) Disconnect header pipes at exhaust manifolds.
- 12) Disconnect starter cable and remove starter.
- 13) Remove engine front supports through bolts.
- 14) Remove clutch linkage and bell housing-to-engine block bolts (Man. Trans.). Remove converter inspection cover and disconnect flywheel from converter. Remove downshift rod. Remove converter housing-to-engine block bolts and adaptor plate-to-converter housing bolt.
- 15) Lower vehicle, attach engine lifting sling. Place jack under transmission.
- 16) Raise engine slightly and carefully pull it from transmission. Carefully raise engine out of vehicle so that nothing is bent or damaged during removal. Install engine on a work stand.

INTAKE MANIFOLD REMOVAL

- 1) Remove air cleaner. Disconnect battery negative cable and throttle cables.

- 2) Drain coolant, disconnect hose from water outlet to radiator, and hoses and line from water outlet to water pump.
- 3) Remove distributor cap and spark plug wires as an assembly. Disconnect distributor wire and distributor vacuum line.

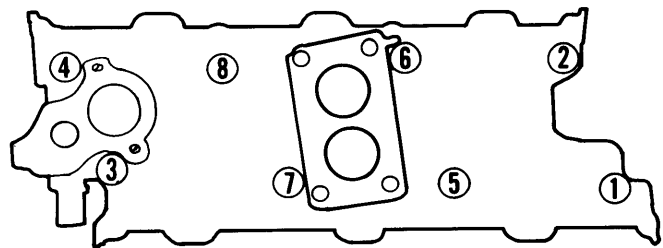

2EM5030

INTAKE MANIFOLD TIGHTENING SEQUENCE

- 4) Remove distributor hold-down screw and clamp. Lift out distributor, noting rotor position for reassembly.
- 5) Remove fuel pump and carburetor.
- 6) Remove intake manifold retaining nuts and bolts. Tap manifold with a plastic mallet to break gasket seal. Lift off manifold.

CYLINDER HEAD REMOVAL

- 1) Remove air cleaner. Disconnect negative battery cable, throttle linkage, and drain coolant.
- 2) Remove distributor cap with spark plug wires as an assembly. Remove distributor vacuum line, distributor coolant outlet line, coolant hose from pump to water outlet, rocker arm covers, fuel line and filter, carburetor and intake manifold.
- 3) Remove rocker arm shafts and oil baffles. Remove push rods and keep in proper sequence.
- 4) Remove exhaust manifold.
- 5) Remove cylinder head bolts and lift off heads.

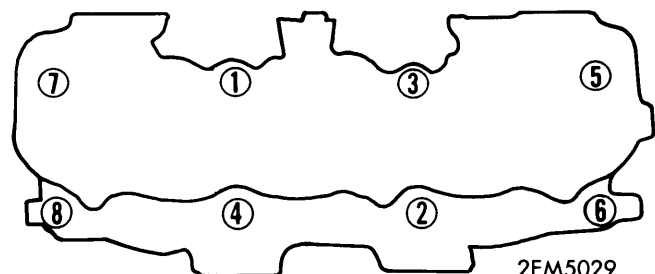

2EM5029

CYLINDER HEAD TIGHTENING SEQUENCE

Capri Engines

1972-73 CAPRI 2600 CC V6 (Cont.)

VALVES							
Engine & Valve	Head Diam. In. (mm)	Face Angle	Seat Angle	Seat Width In. (mm)	Stem Diameter In. (mm)	Stem Clearance In. (mm)	Valve Lift In. (mm)
1972-73 2600 cc							
Intake	1.540 (40)	44°	45°316 (8)	.002 (.05)	.373 (9.5)
Exhaust	1.266 (32)	44°	45°315 (8)	.003 (.08)	.373 (9.5)

VALVE ARRANGEMENT

I-E-I-E-I (front to rear).

VALVE GUIDES

Worn valve guides may be reamed to .003", .015", and .030" oversizes. When going from a standard size valve to an over-size always use reamers in sequence. After reaming, break sharp corner (ID) at top of valve guide. Whenever valve guides are reamed, valve seats must be refaced to maintain proper valve seal.

VALVE STEM OIL SEALS

Install valve stem seal with open side toward head.

VALVE SPRINGS			
Engine	Free Length In. (mm)	PRESSURE Lbs. @ In. (kg @ mm)	
		Valve Closed	Valve Open
1972-73 2600 cc			
Intake	1.89 (48)	147 @ 1.22 (67 @ 31)
Exhaust	1.89 (48)	158 @ 1.68 (72 @ 43)

VALVE SPRING INSTALLED HEIGHT

Install valve springs with open spaced coils away from head. Measure distance between cylinder head spring pad and valve spring retainer. Install spacers if necessary to bring spring to proper specifications. **CAUTION** - Excess spacers will result in possible spring breakage and camshaft lobe wear.

ROCKER ARM ASSEMBLY OVERHAUL

Disassembly - 1) Remove rocker arm shaft stand bolts. Lift off rocker arm assembly.

- Using a drift, drive lock sleeve (pin) out of rocker shaft.
- Remove spring washers, rocker arms, springs and rocker shaft supports.

Reassembly - 1) Replace shaft supports, springs, rocker arms and spring washers.

- Install new drive lock sleeve.

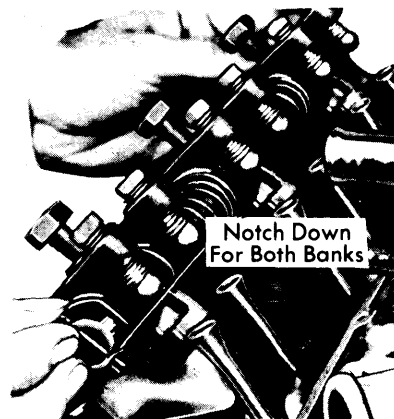

2EM5040

ROCKER ARM ASSEMBLY ALIGNMENT

3) Rocker arm shaft must be placed on cylinder head with oil holes facing down toward head. Position notch on front of rocker shaft downward (see illustration).

4) Tighten rocker arm shaft stand bolts to proper torque specifications.

VALVE CLEARANCE ADJUSTMENT

Preliminary (Cold) Adjustment - 1) Before adjusting valves, torque rocker arm stand bolts to specifications.

2) Adjust valves at TDC on compression stroke in firing order sequence (1-4-2-5-3-6).

3) Rotate crankshaft clockwise, (viewed from front), until number one piston is at TDC. Using a step-type feeler gauge (go and no go), adjust intake to .014" and exhaust to .016".

4) Adjust remaining valves by rotating crankshaft 1/3 turn for each cylinder until all valves have been adjusted.

Final (Hot) Adjustment - 1) Run engine until normal operating temperature is reached.

2) Using a step-type feeler gauge and engine at idle, adjust intake and exhaust valves to .014" intake and .016" exhaust.

1972-73 CAPRI 2600 CC V6 (Cont.)

PISTONS, PINS, RINGS						
Engine	PISTONS	PINS		RINGS		
	Clearance In. (mm)	Piston Fit In. (mm)	Rod Fit In. (mm)	Rings	End Gap In. (mm)	Side Clearance In. (mm)
1972-73 2600 cc	.001-.003 (.025-.076)	.0002-.0004 (.005-.010)	.0007-.0002 (.018-.005)	Comp.	.015-.023 (.381-.584)	.0016 (.041)
				Oil	.015-.055 (.381-1.40)

OIL PAN REMOVAL

Removal – 1) Remove oil level dipstick and bolts attaching fan shroud to radiator. Position shroud over fan. Disconnect battery ground cable at battery. Loosen alternator bracket and adjusting bolts.

- 2) Raise vehicle and drain crankcase.
- 3) Remove splash shield and starter.
- 4) Remove engine front support nuts, and raise engine, placing blocks between front supports and chassis brackets.
- 5) Remove clutch or converter housing cover.
- 6) Remove oil pan bolts and oil pan.

Installation – 1) Coat the block and pan gaskets with sealant compound. Place two piece gasket on face of block.

- 2) Position the front and rear oil pan seals in place with tabs of seals lapping over oil pan gasket.
- 3) Position oil pan on block and install bolts. Tighten bolts from center outward in each direction to specifications.

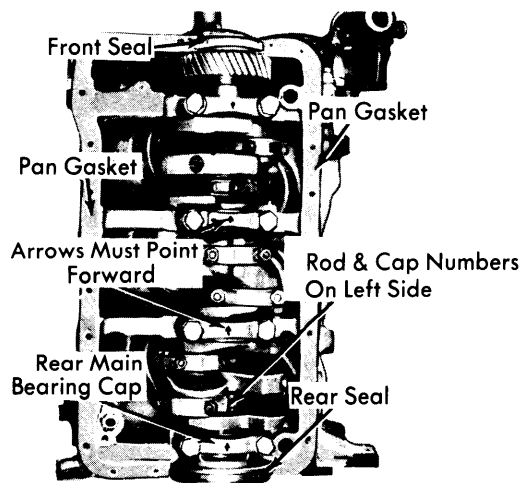

OIL PAN GASKETS & SEALS

PISTON & ROD INSTALLATION

Oil piston, rings, and cylinder walls with light engine oil. Correctly place ring end gaps (see illustration). Insert pistons in their proper bores, making sure connecting rods are fitted to proper journal. The connecting rods are numbered one to three in right bank and four to six in left bank beginning at front of engine.

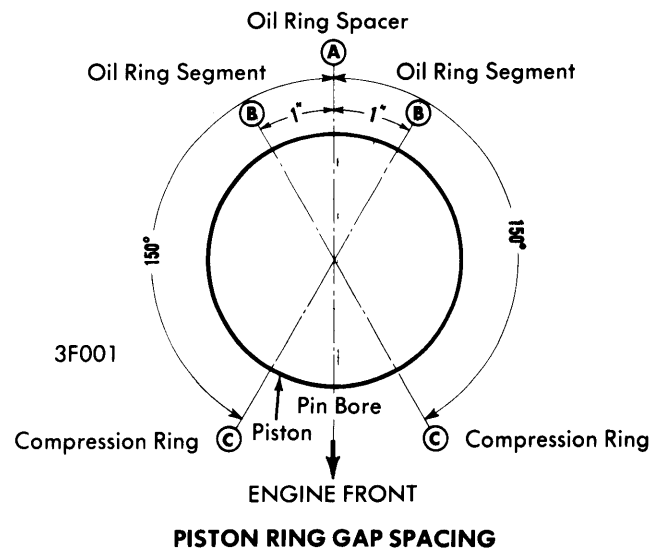

PISTON RING GAP SPACING

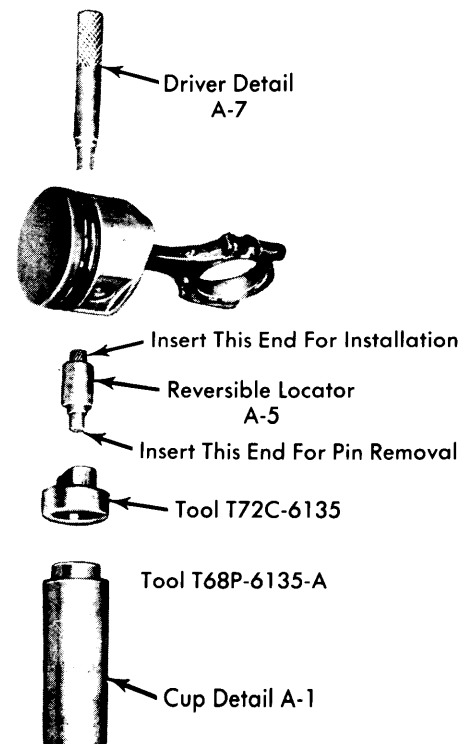

PISTON PIN REMOVAL OR INSTALLATION TOOLS

Capri Engines

1972-73 CAPRI 2600 CC V6 (Cont.)

PISTON PIN REPLACEMENT

Piston pin bore and OD of piston pin must be within specifications. Remove old pin using an arbor press and suitable piston support and driver tool. Assemble piston to rod with notches on piston facing forward. Rod numbers face to left side of engine (see illustration).

FITTING PISTONS

Check piston to cylinder bore clearance by measuring piston and bore diameters. Measure OD of piston at centerline of piston pin bore and at 90° to pin bore axis. Refer to specifications for correct clearance. Oversize pistons are available in .020" and .040" oversizes.

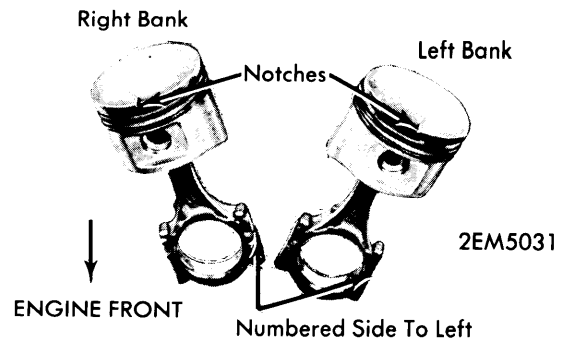

PISTON & ROD RELATIONSHIPS

CRANKSHAFT MAIN & CONNECTING ROD BEARINGS							
Engine	Journal Diam. In. (mm)	MAIN BEARINGS			CONNECTING ROD BEARINGS		
		Clearance In. (mm)	Thrust Bearing	Crankshaft End Play In. (mm)	Journal Diam. In. (mm)	Clearance In. (mm)	Side Play In. (mm)
1972-73 2600 cc	2.243-2.244 (56.97-56.98)	.0005-.002 (.013-.051)	No. 3	.004-.008 (.102-.203)	2.125-2.126 (53.98-54.0)	.0005-.002 (.013-.051)	.0035-.010 (.089-.254)

REPLACEMENT BEARINGS

Determine crankshaft journal clearance in bearing by use of "Plastigage". Place a jack under counterweight adjoining bearing being checked so that weight of crankshaft will not aid in compressing "Plastigage" and provide an erroneous reading.

If bearing clearance using standard size bearing inserts is excessive, a .002" undersize bearing half may be used in combination with a standard size bearing half. If .002" undersize bearings are used on more than one journal, they must be positioned in cylinder block rather than bearing cap. If standard and .002" undersize combinations do not bring bearing clearance within specified limits (see specifications), crankshaft will have to be refinished and undersize bearings installed, which are available in .010", .020", .030", and .040" undersizes.

THRUST BEARING ALIGNMENT

Thrust bearing is the number three main bearing counting from front of engine. Align thrust bearing by forcing crankshaft forward and thrust bearing rearward. While holding in this position tighten cap bolts to specifications.

REAR MAIN BEARING OIL SEAL

Remove transmission, clutch pressure plate and clutch disc or flywheel, flywheel housing and rear plate. Punch two holes in seal on either side of crankshaft above bearing cap. Insert metal screws in holes, using screwdrivers or pry bars, pry out seal. Install new seal with oil on OD and Lubriplate on ID of seal. Drive new seal in position using a suitable tool (see illustration).

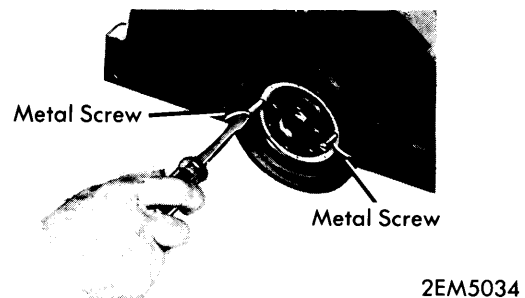

REMOVING CRANKSHAFT REAR OIL SEAL

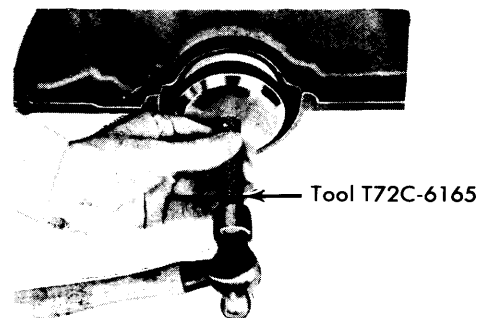

INSTALLING CRANKSHAFT REAR OIL SEAL

1972-73 CAPRI 2600 CC V6 (Cont.)

ENGINE FRONT COVER

Removal - 1) Remove oil pan, radiator, alternator, drive belts, water pump, water lines and pan.

2) Remove drive pulley. If necessary, remove guide sleeves from block.

3) Remove front cover attaching bolts. Tap cover lightly with a plastic mallet to break seal and remove cover.

Installation - 1) Apply sealing compound to gasket surfaces on cylinder block and back side of front cover plate. Position gasket and front cover plate and install two cover plate retaining bolts.

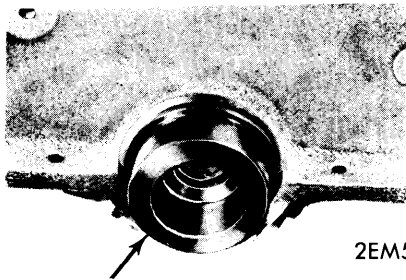

Tool T72C-6150

2EM5036

ALIGNING FRONT COVER

2) Fit new seal rings to guide sleeves and insert guides in block with chamfered end toward front cover.

3) Apply sealing compound to front cover and place gasket on front cover.

4) Place front cover on engine and start all retaining screws. Center cover by inserting tool (T72C-6150) in oil seal (see illustration).

5) Tighten front cover screws to specifications.

ENGINE FRONT COVER OIL SEAL

Removal - Remove radiator and crankshaft pulley. Pull front cover seal out with a suitable tool (see illustration).

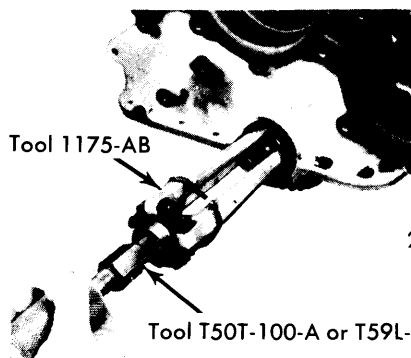

Tool 1175-AB

2EM5037

Tool T50T-100-A or T59L-100-B

REMOVING FRONT OIL SEAL

Installation - Slide tool and new seal over crankshaft. Push oil seal in until tool abuts against front cover (see illustration). Replace crankshaft pulley and radiator. Adjust fan belt tension.

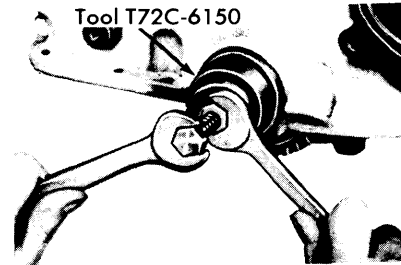

Tool T72C-6150

2EM5038

INSTALLING FRONT OIL SEAL

CAMSHAFT			
Engine	Journal Diam. In. (mm)	Clearance In. (mm)	Lobe Lift In. (mm)
1972-73 2600 cc No. 1	1.650 (41.91)	.002 (.051)	.255 (6.48)
No. 2	1.635 (41.53)		
No. 3	1.620 (41.15)		
No. 4	1.605 (40.77)		

CAMSHAFT GEAR REPLACEMENT

Removal - 1) Drain cooling system and crankcase. Remove oil pan and radiator.

2) Remove front cover.

3) Pry camshaft gear off. Remove thrust plate, spacer and key.

Reassembly - 1) Replace spacer and thrust plate on camshaft.

2) Install key in camshaft and press camshaft gear on until it seats against spacer. *NOTE* - Make sure timing marks are properly aligned before pressing on camshaft gear.

CAMSHAFT & BEARING REPLACEMENT

Removal - 1) With camshaft gear removed, remove camshaft. Drive out rear bearing bore plug.

2) Using a suitable puller, remove camshaft bearings. Use care not to damage bearing bores.

Capri Engines

1972-73 CAPRI 2600 CC V6 (Cont.)

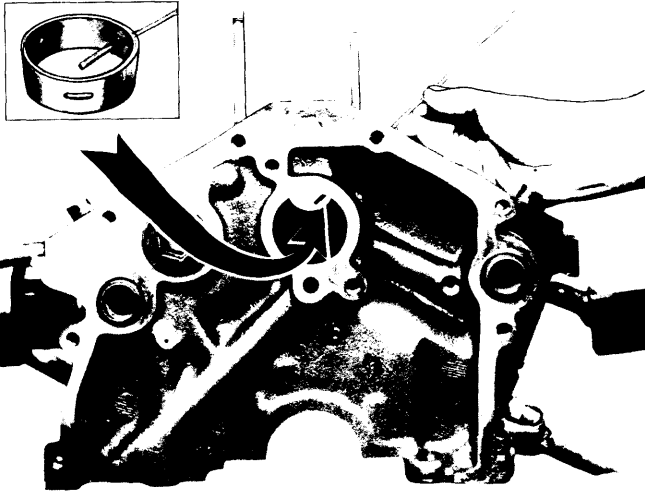

2EM5041

OIL HOLE ALIGNMENT FOR NO. 2 & 3 CAMSHAFT BEARINGS

Installation – 1) New camshaft bearings are available in standard and undersize. They are prefinished and require no reaming.

2) Using suitable tools, press in new bearings. Check oiling holes in bearings to make sure they are properly aligned (see illustration).

3) Install new bearing bore plug. Replace camshaft, spacer, thrust plate, key and camshaft gear.

CAMSHAFT END THRUST

1) Back off rocker arm adjusting nuts until camshaft has no valve spring load on tappets.

2) Using a dial indicator, push camshaft toward rear of engine. Place a large screwdriver between gear and block, pull camshaft forward and release it. Compare dial indicator reading with specifications.

3) If end play is excessive, replace thrust plate.

CHECKING CAMSHAFT LOBE LIFT

Check lift of each camshaft lobe in consecutive order as follows:

1) Remove rocker arm shaft assemblies, making sure each push rod is in valve lifter socket. Install a dial indicator so that ball socket adapter of indicator rests on the end of push rod and in same plane as push rod movement.

2) With an auxiliary starter switch connected to starter solenoid and ignition switch "OFF", bump crankshaft until tappet is on base circle of camshaft lobe. This will be push rods lowest point.

3) Zero dial indicator and continue to rotate crankshaft until push rod is in fully raised position (highest indicator reading). Compare total lift from indicator readings with specifications.

4) To check accuracy of indicator readings, continue to rotate crankshaft until indicator reads zero. If lift on any lobe is .005" less than specifications, camshaft and tappet operating on worn lobe must be replaced.

VALVE TIMING				
Engine	INTAKE		EXHAUST	
	Open (BTDC)	Close (ABDC)	Open (BBDC)	Close (ATDC)
1972-73 2600 cc	20°	56°	62°	74°

VALVE TIMING

Valve timing is correct when marks on crankshaft gear align with marks on camshaft gear.

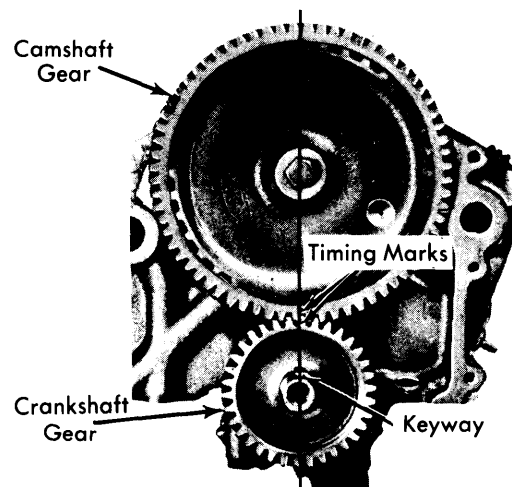

2EM5039

TIMING MARKS

ENGINE OILING

ENGINE OILING SYSTEM

The V-6 engine is pressure feed by a rotor type oil pump, which filters all oil through a full flow filter before entering engine. An oil gallery supplies oil to crankshaft main bearings, from there through slanted passages in crankshaft to connecting rod journals. Connecting rod big ends have a squirt hole which sprays oil on thrust side of cylinder bores. Oil from the oil gallery also feeds camshaft main bearings, which have

grooves 180° of their circumference. From these grooves passages lead to distributor drive gear and rocker arm shafts.

Crankcase Capacity – 5 1/4 qts. (with filter).

Oil Filter Type – Full Flow.

Normal Oil Pressure – 40-55 psi @ 1500 RPM.

Pressure Regulator Valve – Non-adjustable.

1972-73 CAPRI 2600 CC V6 (Cont.)

ENGINE OILING (Cont.)

OIL PUMP

Oil pump is a rotor-type pump. A non-adjustable spring loaded relief valve limits maximum pressure to approximately 50 psi. To service oil pump remove oil pan (See Oil Pan Removal). Remove bolt that retains oil pick-up screen to main bearing cap. Remove oil pump attaching bolts and lift off oil pump. Remove oil pump drive shaft. **NOTE** — When reinstalling oil pump drive shaft, make sure pointed end, (pointed end is closest to pressed-on flange), is facing inward. Lift off pump cover and remove rotors. To remove pressure relief spring, drill a small hole in pressure relief valve plug. Screw in a metal screw and pull plug out. A new plug must be used when spring

is reinstalled. Check clearances, (see illustration) against specifications listed below. If rotor wear is present, replace rotors as an assembly only. Prime pump before remounting in engine.

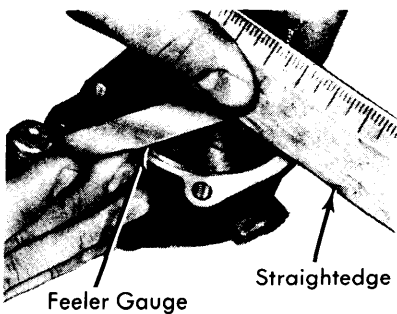

Feeler Gauge

Straightedge

2EM5042

OIL PUMP ROTOR END PLAY

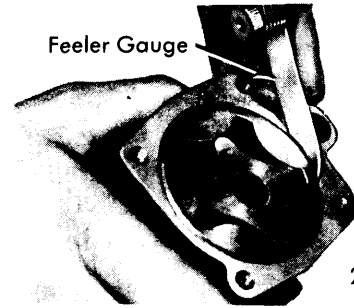

Feeler Gauge

2EM5043

OIL PUMP OUTER RACE CLEARANCE

Oil Pump Specifications

Relief Valve Spring Tension.....	13.6-14.7 Lbs. @ 1.39"
Drive Shaft-to-Bearing Clearance.....	.001-.002"
Relief Valve Clearance001-.002"
Rotor Assembly End Clearance.....	.001-.004"
Outer Race-to-Housing (Radial).....	.005-.011"

ENGINE COOLING

WATER PUMP

Removal — 1) Drain coolant, and remove lower radiator hose and heater return hose.

2) Loosen alternator mounting bolts and remove belt. Remove fan and pulley.

3) Remove water pump bolts. Remove water pump, water inlet housing and thermostat from front cover.

Reinstallation — 1) Apply sealer to both sides of a new gasket, and place gasket on water pump.

2) Position water pump on front cover using two bolts finger tight.

3) Apply sealer to both sides of new inlet housing gasket and place gasket on water pump. Install thermostat and rubber gasket. Position inlet housing and tighten bolts. Install and tighten all remaining bolts. Note that different length bolts are used.

THERMOSTAT

To test thermostat, suspend in water so that it doesn't touch side of container. Gradually heat water, checking water temperature frequently to see when thermostat starts to operate. If thermostat does not function properly, replace. See table below for opening temperatures.

Thermostat	Opening Temperatures
New — Starts to Open.....	185-192°F.
Fully Open	210-216°F.
Used — Starts to Open.....	178-199°F.
Fully Open	203-223°F.

Cooling System Capacity — 8 1/4 qts. (with heater).

Pressure Radiator Cap — Opens at 13 psi.

TIGHTENING SPECIFICATIONS

Application	Ft. Lbs. (mkg)
Cylinder Head	
Step 1.....	30-40 (4.5-5)
Step 2.....	40-50 (5.5-7)
Step 3.....	65-80 (9-11)
Intake Manifold	
Step 1.....	2-6 (.3-.8)
Step 2.....	15-18 (2-2.5)
Main Bearing Caps.....	65-75 (9-10)
Connecting Rod Bearing Caps	22-26 (3-3.6)
Crankshaft Timing Gear	32-36 (4.5-5)
Camshaft Timing Gear	32-36 (4.5-5)
Crankshaft & Balance Shaft Pulley.....	32-36 (4.5-5)
Oil Pump	10-12 (1.4-1.7)
Oil Pan & Rocker Arm Covers	
Step 1.....	2-4 (.3-.6)
Step 2.....	5-8 (.7-1)
Flywheel	40-50 (5.5-7)
Front Cover	9-12 (1-1.7)
Water Pump	6-12 (.8-1.7)
Rocker Shaft Supports	32-36 (4.4-5)
Spark Plugs	22-28 (3-3.9)
Temperature Sender Unit.....	8-12 (1-1.7)
Threaded Plugs In Engine Block (Front)	42-45 (5.8-6)