

Austin Engines

1968-71 AUSTIN AMERICA 4 CYLINDER

GENERAL SPECIFICATIONS										
Model	Displ.		Carburetor	HP at RPM	Torque (Ft. Lbs. at RPM)	Compr. Ratio	Bore		Stroke	
	cu. ins.	cc					in.	mm	in.	mm
1275 cc	78	1275	58@5250	60@3000	8.8-1 ①	2.78	70.61	3.2	81.28

① — 8.1-1 compression ratio is available.

ENGINE IDENTIFICATION

Engine number is stamped on a metal plate fixed to right side of engine block.

ENGINE REMOVAL

- 1) Drain cooling system and remove hood. Disconnect ground strap from clutch housing and remove electrical leads from distributor, coil and generator (alternator). Remove starter.
- 2) Remove air cleaner and carburetor(s). Disconnect heater hoses and heater cables (if equipped). Release clutch lever spring. Remove slave cylinder bolts and move cylinder out of way. **NOTE — Do not disconnect fluid line from slave cylinder.**
- 3) Remove exhaust pipe-to-manifold clamp and release exhaust pipe from its location on transmission case. Remove bolts securing exhaust pipe extension to differential casing and remove casing. On late model automatic transmission models, remove bell crank lever guard. On early model automatic transmission models, pull back rubber boot and disconnect selector cable yoke from bell crank lever.
- 4) Disconnect speedometer cable and gear shift selector rod. Raise front of vehicle and place jack stands under frame side members. On automatic transmission models only, remove sway bar.
- 5) Disconnect both drive shaft couplings and push sliding joints onto shafts to separate couplings. Attach suitable hoist to engine at cylinder head. Remove left front engine mount nuts and take weight of engine on hoist. Remove right side engine mounting bracket. Lift engine from vehicle.
- 6) To install, reverse removal procedure.

INTAKE & EXHAUST MANIFOLD REMOVAL

- 1) Remove air cleaner and carburetor(s). Remove either PCV valve or breather pipe. Remove vacuum pipe servo. Take off both heat shields and their gaskets. Remove nuts mounting intake manifold and remove manifold.

- 2) Following procedure is applicable if both intake and exhaust manifolds are to be removed: Disconnect and remove tail pipe assembly. Disconnect transmission casing from center exhaust pipe and slide clamp off. Unscrew remaining exhaust manifold nuts. Remove center section of exhaust pipe out from bottom and remove intake and exhaust manifolds out the top. To install, reverse removal procedure.

CYLINDER HEAD REMOVAL

- 1) Drain cooling system and disconnect battery ground cable. Remove upper radiator hose from thermostat housing. Remove air cleaner and carburetor(s). Remove valve cover and gasket.
- 2) Remove spark plug wires and spark plugs. If vehicle is equipped with a heater, disconnect and remove hose and control cable. Remove by-pass hose.
- 3) Remove intake and exhaust manifolds as previously described.
- 4) Remove rocker shaft bracket nuts and lift off rocker assembly together with brackets.
- 5) Remove push rods and keep them in order of removal. Remove cylinder head nuts and lift head straight up to prevent studs from binding.

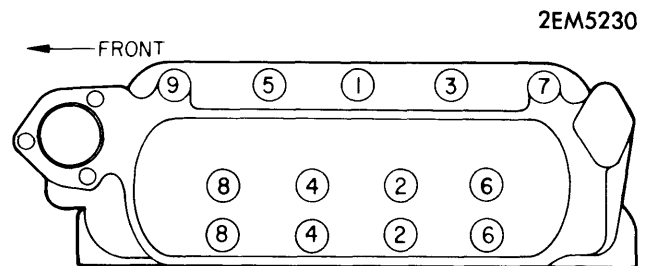

CYLINDER HEAD TIGHTENING SEQUENCE

VALVES							
Engine & Valve	Head Diam.	Face Angle	Seat Angle	Seat Width	Stem Diameter	Stem Clearance	Valve Lift
1275 cc							
Int.	1.307-1.312"	45°	45°2793-.2798"	.0015-.0025"	.318"
Exh.	1.1515-1.1565"	45°	45°2788-.2793"	.0015-.0025"	.318"

1968-71 AUSTIN AMERICA 4 CYLINDER (Cont.)

VALVE ARRANGEMENT

E-I-I-E-E-I-I-E (front-to-rear).

VALVE GUIDES

1) With cylinder head removed, remove valve spring at valve where service is required. Place cylinder head with machined face down on clean surface. Drive valve guide down into combustion space with suitable drift.

2) Drift should be hardened steel, 7/16" in diameter, and not less than 4" long. Drift should be machined to 9/32" for a distance of 1" at one end. This is to allow drift to engage bore of guide.

3) When installing new guides, they should be driven in from top of cylinder head. Intake valve guides must be inserted with largest chamber at top. Exhaust valve guides should have counterbored ends at bottom. Drive guides into combustion spaces until they are 19/32" above machined surface of valve spring seating surface.

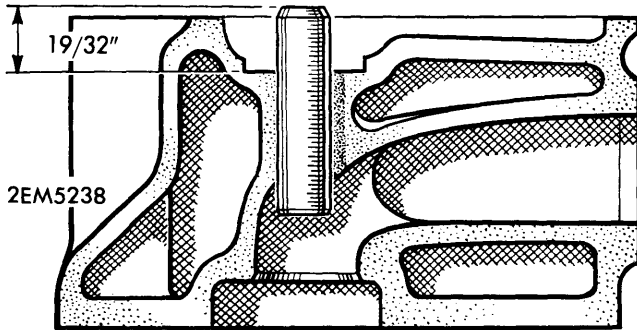

VALVE GUIDE INSTALLATION HEIGHT

VALVE STEM OIL SEAL & VALVE SPRING REPLACEMENT

1) With cylinder head removed, use suitable tool (18G-45) to compress valve springs. Remove keepers, valve spring cups, springs, and valve spring seats. Remove valve stem oil seal (intake valves only) and remove valve.

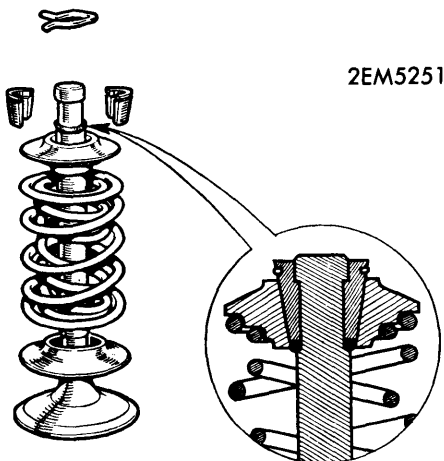

DOUBLE VALVE SPRING ASSEMBLY

2) To install, place valve into guide, followed by spring seat (if equipped). Slide and oil seal down each intake valve stem and fit over valve guide. Install spring seat, springs and spring cups. Compress spring and install keepers.

VALVE SPRINGS			
Engine	Free Length	PRESSURE (LBS.)	
		Valve Closed	Valve Open
1275 cc	1.95"	79.5@1.383"	124@1.065"

ROCKER ARM ASSEMBLY

Removal - 1) Drain cooling system and remove rocker cover. Loosen rocker shaft bracket nuts and external cylinder head stud nuts gradually, one turn at a time, until all load is released.

NOTE - It is important that external cylinder head nuts are loosened at the same time to avoid possibility of head distortion.

2) Remove rocker arm bracket nuts and remove rocker assembly together with brackets. Remove push rods, marking them for reinstallation in their original positions. To install, reverse removal procedure.

Disassembly - Remove screw holding rocker shaft in front rocker mounting bracket. Remove split pins, flat washer and spring washer from end of shaft and slide rockers, brackets and springs from shaft. Remove threaded plug installed in one end of shaft and clean out oil passages.

Reassembly - When reassembling, start with front mounting bracket and hold it with screw. Follow with remaining brackets and springs. Replace in original positions on shaft. The threaded plug end of shaft should be positioned to front of engine.

VALVE TAPPETS

With carburetors, manifold, rocker cover and rocker assembly removed, remove push rods. Remove tappet covers and lift out tappets, keeping them in order. When installing, tappets should fall into corresponding guides under their own weight after being coated with engine oil.

VALVE CLEARANCE ADJUSTMENT

With engine cold, set clearance to .012". To check valve clearances, turn crankshaft until valves in first column are fully open, then valves in second column may be checked and adjusted as required.

Valves Open	Valves to Adjust
1.....	8
3.....	6
5.....	4
2.....	7
8.....	1
6.....	3
4.....	5
7.....	2

Austin Engines

1968-71 AUSTIN AMERICA 4 CYLINDER (Cont.)

PISTONS, PINS, RINGS						
Engine	PISTONS Clearance	PINS		RINGS		
		Piston Fit	Rod Fit	Rings	End Gap	Side Clearance
1275 cc	.0015-.0021"	①	.0008-.0015"	Comp.		
				No.1	.011-.016"	.0015-.0035"
				No.2	.008-.013"	.0015-.0035"
				No.3	.008-.013"	.0015-.0035"
			Oil	.012-.028"	

① — Hand Push Fit

PISTON & ROD ASSEMBLY

- 1) Drain cooling system, transmission casing and external oil filter.
- 2) Remove engine, disconnect clutch and flywheel. Remove flywheel housing, transmission and cylinder head. *NOTE — On automatic transmission models only, remove converter and converter cover.*
- 3) Unlock and remove bearing cap bolts. Mark cap and connecting rod relationship for reinstallation in same cylinder. Remove bearing cap. Extract piston and rod assembly through top of cylinder.
- 4) To install piston and rod assembly, reverse removal procedure. *NOTE — Piston ring gaps should be set 90° to each other. Top and bottom rod bearings are interchangeable.*

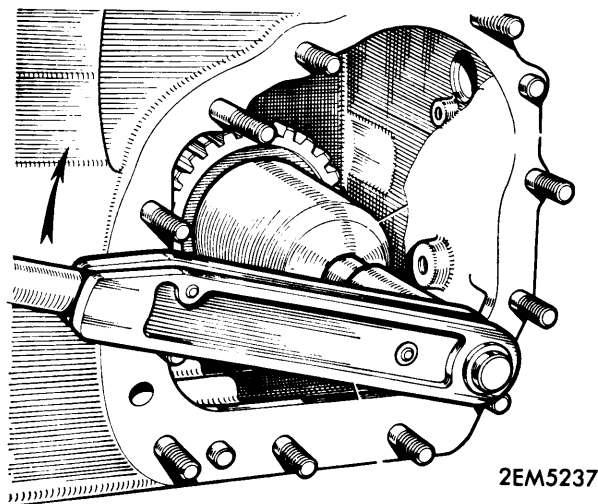

CHECKING RING GAP

PISTON PIN REPLACEMENT

- 1) To remove piston pin, use suitable tool (18G-1002), to avoid crushing or distorting piston. Hold hexagon body of tool in vise with cut-out up.
- 2) Screw large nut back until flush with end of center screw. Push screw and nut forward until nut contacts thrust race. Slide parallel sleeve, short length diameter first, onto center screw, up to its shoulder.
- 3) Place piston assembly on center screw and attach remove/replacer bushing, longest diameter portion toward piston. Screw stop nut onto center screw and adjust until there is about 1/32" endplay in whole assembly.

4) Lock stop nut securely in position with lock screw and check that curved face of body is clean. Slide piston assembly into position against curved face. Check that piston rings are over cut-out in tool body.

5) Screw large nut up to thrust race and hold lock screw (not stop nut) with a wrench. Turn large nut until pin is pulled out of piston.

6) To install pin, remove large nut from tool and pull center screw out a few inches. Slide parallel sleeve, longest length diameter part first, onto center screw up to its shoulder.

7) Place piston on connecting rod small end up to undercut. Smear pin with thin oil and slide it over center screw and into piston bore up to face of connecting rod. Slide remover/replacer bushing, short spigot toward pin, onto center screw.

8) Screw stop nut onto center screw and adjust until there is about 1/32" end play. Lock nut securely in position with lock screw. Check that curved face of body is clean and slide piston into position against curved face. Check that piston rings are over cut-out in tool body.

9) Screw large nut onto center screw until it contacts thrust race. Using a torque wrench set to 16 ft. lbs., and holding lock screw with wrench, turn large nut with torque wrench to pull pin until flange of remover/replacer bushing is 1/32" from piston skirt.

NOTE — It is important that care is taken to prevent flange from contacting piston.

10) If torque wrench reading has not reached 16 ft. lbs. during the pull, fit of pin to connecting rod is not correct and piston and pin must be replaced. Ensure large nut and center screw of tool are lubricated with engine oil.

11) Check assembly and make sure that piston pivots freely on pin and is free to slide sideways. If assembly is satisfactory, reinstall in engine.

FITTING PISTONS

Select smallest oversize necessary when installing new pistons in engine. Pistons are marked with actual oversize dimensions enclosed in an oval. These markings indicate actual bore size to which they must be fitted, the required clearance has been allowed for. See following table for oversizes and bore sizes:

Engine	Oversize	Suitable Bore Size
1275 cc	Standard	2.7800-2.7803"
	+ .010"	2.7900-2.7903"
	+ .020"	2.8000-2.8003"

1968-71 AUSTIN AMERICA 4 CYLINDER (Cont.)

CRANKSHAFT MAIN & CONNECTING ROD BEARINGS							
Engine	MAIN BEARINGS			Crankshaft Endplay	CONNECTING ROD BEARINGS		
	Journal Diam.	Clearance	Thrust Bearing		Journal Diam.	Clearance	Sideplay
1275 cc	2.0005-2.000"	.0010-.0027"	Center	.002-.003"	1.6254-1.626"	.0010-.0025"	.006-.010"

CRANKSHAFT & MAIN BEARING SERVICE

1) Drain transmission casing and external oil filter. Remove engine as previously described. Extract flywheel and clutch assembly, remove flywheel housing. On automatic transmission models only, remove converter and converter housing.

2) Remove timing cover and gears. Remove transmission. Place engine upside down on engine stand. *NOTE — If spark plugs are removed, crankshaft will be easier to turn.*

3) Check crankshaft end thrust. If thrust play exceeds .002-.003", thrust washers must be replaced.

4) Remove connecting rod bearing caps and bearings. Keep bearings in order for correct reinstallation. Remove main bearing caps complete with bottom bearing halves. *NOTE — Bottom half of thrust washers are removed with center main bearing cap. Caps and respective bearings should be kept together.*

5) Remove crankshaft, two remaining halves of thrust washers and top halves of main bearings from crankshaft. Bearings, both main and connecting rod, are available in .010", .020", .030", and .040" undersizes for 1098 cc engines. The crankshaft for the 1275 cc engine may be ground only to .010" undersize without heat treatment.

6) To install crankshaft or bearings, reverse removal procedure making sure that thrust washers are installed properly.

ENGINE FRONT COVER & OIL SEAL

1) Drain cooling system and remove radiator. Loosen generator mounting bolts and remove fan belt. Bend back tab on crankshaft pulley securing bolt and carefully pry pulley and damper assembly from crankshaft.

2) Remove bolts holding front cover to engine and carefully remove cover. Using suitable tool (18G-134 and adapter 18-134BD) remove front seal.

3) Ensure oil thrower behind crankshaft pulley is fitted with index mark "F" away from engine. Fill groove between lips of oil seal with grease and using suitable tool (18G-1044) centralize oil seal on crankshaft.

NOTE — On early models only, front cover and oil thrower must be fitted together. When refitting, ensure oil thrower is fitted with its concave side facing away from engine. Use suitable tool (18G-138) to centralize rubber seal on crankshaft.

CAMSHAFT			
Engine	Journal Diam.	Clearance	Lobe Lift
1275 cc			
Front	1.6655-1.6660"	.001-.002"
No.2	1.62275-1.62325"	.001-.002"
No.3	1.37275-1.37350"	.001-.002"

CAMSHAFT REMOVAL

1) Drain transmission and remove engine as previously described.

2) Disconnect and remove transmission.

3) Remove rocker shaft and push rod as previously described.

4) Remove front cover and timing gears. Remove distributor assembly and camshaft locating plate.

5) Invert engine to allow tappets to fall clear from camshaft. Withdraw camshaft rotating it to clear distributor drive. Oil pump drive shaft may come out with camshaft.

6) To install, reverse removal procedure. *NOTE — Ensure oil pump driving flange is properly seated on oil pump drive shaft. Fit white side of camshaft locating plate toward camshaft.*

CAMSHAFT BEARING SPECIAL PROCEDURE

NOTE — It is necessary to complete all steps under Camshaft Removal. On manual transmission models only, remove transmission case and flywheel housing. On automatic transmission models only, remove both converter and converter cover.

When old bearings are punched out, new ones must be tapped into position. Bearings are easily damaged and use of service tool 18G-124A is recommended. Tool consists of a body with built in thrust race, screw wing nut, stop plate, "D" washer and handle. Tool is used in conjunction with special adaptors.

CENTER BEARING REPLACEMENT

1) Insert suitable pilot adaptor (18G-124K) into camshaft front bore, from inside of block and insert suitable adaptor (18G-124B) into center bearing from rear, small end first.

Austin Engines

1968-71 AUSTIN AMERICA 4 CYLINDER (Cont.)

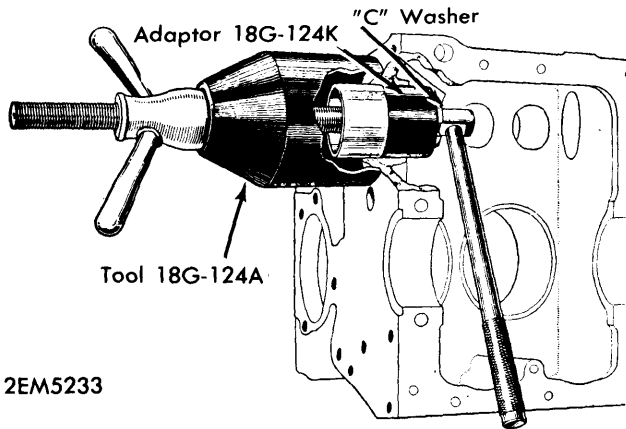

2EM5233

REMOVING CAMSHAFT BEARINGS

2) With body of tool positioned on center screw, pass screw through pilot adaptor and adaptor in center liner. Place slotted washer on flat at rear center screw and insert handle into screw behind slotted washer. Tighten up wing nut to remove bearing.

NOTE — When installing bearings, line up oil holes in bearings and cylinder block and make sure that they remain correctly positioned during installation.

3) To install center bearing, insert suitable pilot adaptor (18G-124K) into camshaft front bearing from inside of block. Place new bearing on small end of adaptor (18G-124B) and place adaptor in center bore from rear, largest diameter first.

4) With body of tool positioned on center screw, insert screw through pilot adaptor in center bore. Place larger "D" washer on center screw with cut away part from butt joints of bearing; this joint must be covered by washer.

5) Place slotted washer and handle in center screw and tighten up wing nut to pull bearing into position.

FRONT & REAR BEARING REPLACEMENT

1) Insert small end of suitable adaptor (18G-124K) into camshaft front bearing, from inside block, and thread body of tool onto center of screw. Pass screw through adaptor from front of block. Place slotted washer on flat at rear of center screw.

2) Insert handle into center screw behind slotted washer and tighten up wing nut to remove worn bearing. The rear bearing is removed by the same method. Using suitable adaptor (18G-124M) remove bearing from rear of block.

NOTE — When installing bearings, line up oil holes in bearings and cylinder block and make sure that they remain correctly positioned during installation.

3) Place new bearing on smallest diameter of suitable adaptor (18G-124K) and insert adaptor into camshaft front bearing bore from inside block, largest diameter first.

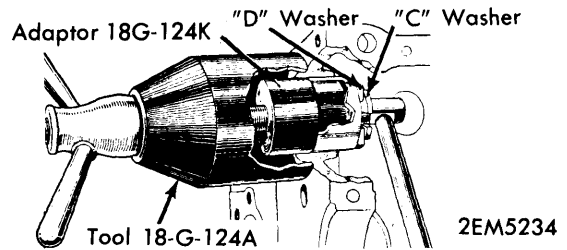

2EM5234

REPLACING CAMSHAFT BEARINGS

4) Thread body of tool onto center screw and pass through adaptor located in front of bearing from front of block. Position larger "D" washer on center screw with cut away portion turned away from butt joint of bearing. *NOTE* — This joint must be covered by washer.

5) Place slotted washer on flat at rear of center screw and insert handle into screw behind slotted washer. Tighten wing nut to pull bearing into position. Replace rear bearing by same method, using suitable adaptor (18G-124M) and pulling bearing into position from rear of block. Do not use "D" washer when installing rear bearing.

REAMING BEARINGS

NOTE — Make sure that cutting tool is kept clear of cuttings at all times. Cutting tool should be removed from bearing half way through and cuttings removed. Feed reamer very slowly and keep cutters dry. Arbor should be lightly lubricated before assembling cutters and pilot. Clean thoroughly when operation is completed.

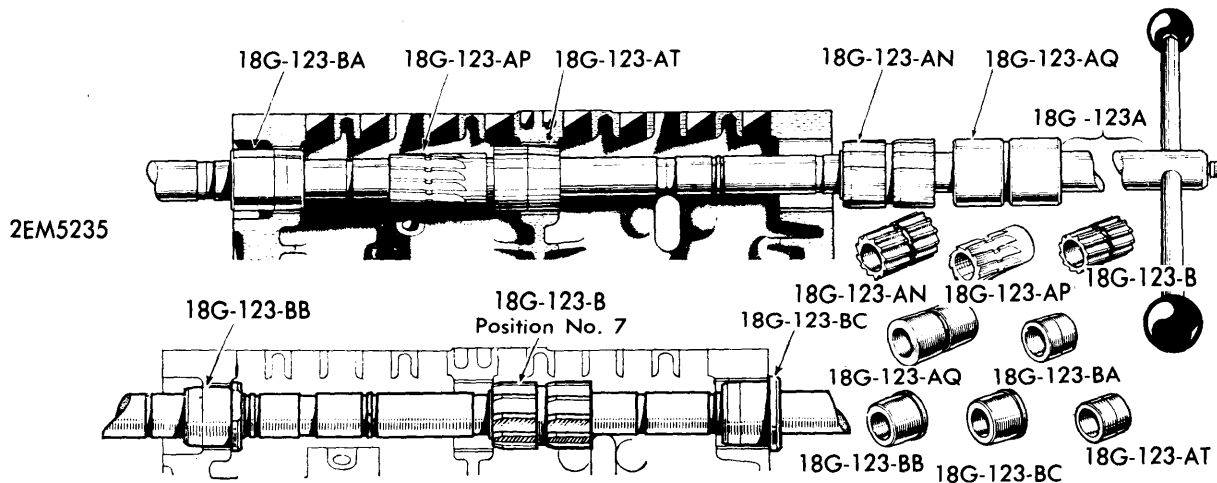

2EM5235

CAMSHAFT BEARING REAMER

1968-71 AUSTIN AMERICA 4 CYLINDER (Cont.)

1) Insert suitable taper pilots (18G-123AT and 18G-123BA) into center and rear bearing respectively. Place suitable parallel pilot (18G-123AQ) on arbor, followed by suitable cutter (18G-123AN).

2) Thread arbor through front and center bearings, place suitable cutter (18G-123AP) on arbor, and thread arbor through taper pilot in rear bearing. Secure cutters and pilots in respective positions. Cutter (18G-123AN) should be located in No. 10 and cutter (18G-123AP) should be located in No. 7 on arbor.

3) Cutter for front bearing will cut first with arbor piloting in center and rear bearings. Cutter for rear liner will follow with arbor piloting in front and center bearings. Clear away all cuttings before plain pilot is allowed to enter front bearing. When cut in rear bearing is finished, free cutters and remove arbor.

4) To ream center bearing, insert suitable pilots (18G-123BC and 123BB) in front and rear bearings. Thread arbor through pilot in front bearing and place cutter for front bearing on arbor. Thread arbor through center bearing and pilot located in rear bearing.

5) Secure cutter and pilot in position. Suitable adaptor (18G-123B) should be located in No. 7 position on arbor. Ream center bearing, release cutter, and remove arbor.

6) Keep sprockets in this position, engage crankshaft gear keyway with key on crankshaft and rotate camshaft until camshaft sprocket keyway and key are aligned. Push sprockets on far as they will go. Secure camshaft gear with lock washer and nut.

7) Replace oil thrower with face marked "F" or concave side away from engine.

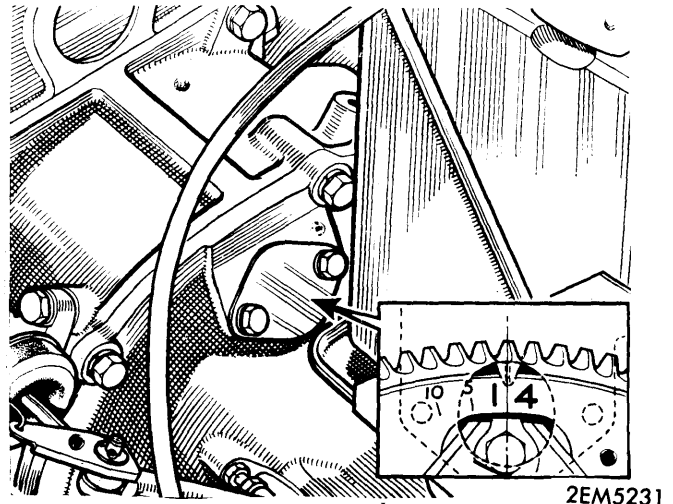

FLYWHEEL TIMING MARKS

2EM5231

VALVE TIMING

1) Set No. 1 cylinder intake valve clearance to .029" with engine cold. Turn crankshaft until valve is about to open. On manual transmission models only, the 1/4 TDC indicating mark on flywheel should be opposite pointer in clutch cover inspection plate opening. On automatic transmission models only, the 1/4 TDC indicating mark on converter should be opposite pointer on converter housing. On both models valve should be about to open and No. 4 piston will be at TDC compression stroke.

2) After timing has been checked, valve clearance should be reset to specification. See *Valve Clearance Adjustment*.

VALVE TIMING				
Engine	INTAKE		EXHAUST	
	Open (BTDC)	Close (ABDC)	Open (BBDC)	Close (ATDC)
1275 cc	5°	45°	51°	21°

TIMING CHAIN REPLACEMENT

1) Remove engine front cover as previously described. Remove camshaft sprocket nut and lock washer. Note that locating tag on lock washer fits into keyway of camshaft sprocket.

2) Camshaft and crankshaft sprockets may now be removed together with timing chain. Ease each sprocket forward a fraction at a time using small levers. Note number of packing washers immediately behind crankshaft sprocket.

3) When reassembling original components, the same number of washers should be replaced. If new components have been installed which would disturb alignment of sprockets, thickness of washers will have to be determined.

4) To determine washer thickness, place a straightedge across sides of camshaft sprocket teeth and measure the gap between straightedge and crankshaft gear.

5) When replacing timing chain and sprockets, set crankshaft with keyway at TDC and camshaft with keyway at approximately one o'clock position, as viewed from front. Assemble sprockets into timing chain with two marks on sprockets opposite each other.

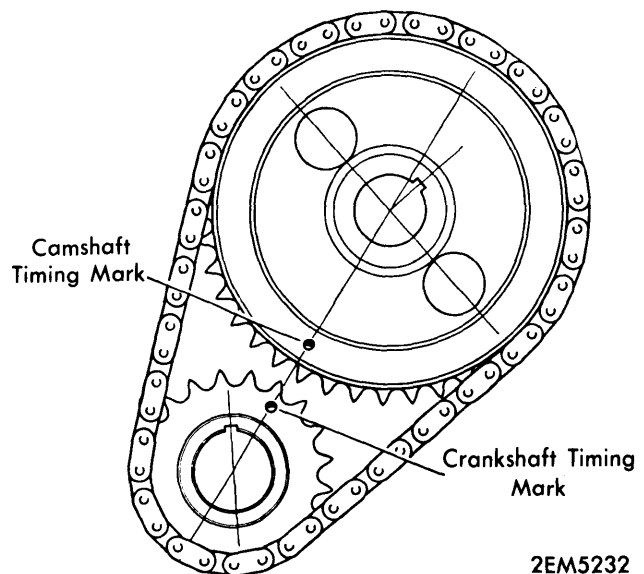

CORRECT POSITION - VALVE TIMING

2EM5232

1968-71 AUSTIN AMERICA 4 CYLINDER (Cont.)

ENGINE OILING

ENGINE OILING SYSTEM

Engine and transmission are oiled as an assembly. Oil is drawn from the base of transmission casing by a rotor type oil pump mounted on rear of crankcase. Oil is delivered to a full-flow external oil filter and then to drilled passages for crankshaft, connecting rod and camshaft bearings. Holes in the connecting rods deliver oil to cylinder walls. Rockers are provided with oil at reduced pressure from camshaft front bearing. Tappets are lubricated by oil off push rods.

Crankcase Capacity – Automatic transmission models only, 8 quarts. Manual transmission models only, 5 1/8 quarts. Values include axle capacity.

Oil Filter – Full-flow replaceable element type. Located on right side of crankcase.

Normal Oil Pressure – 15 psi at idle and 60 psi running.

OIL PUMP

Hobourn-Eaton Type – 1) Remove engine.

2) On manual transmission models only, remove clutch, flywheel and flywheel housing. On automatic transmission models only, remove converter, flywheel and converter housing.

3) Bend back locking washers and remove bolts securing pump to crankcase. Withdraw oil pump, noting slot in driving shaft.

4) With rotors in pump body, place a straightedge across joint face of pump body and measure clearance between top

face of rotors and under side of straightedge. Clearance must not exceed .005". Excessive tolerance may be corrected by removing cover locating dowels and carefully lapping joint face of pump body.

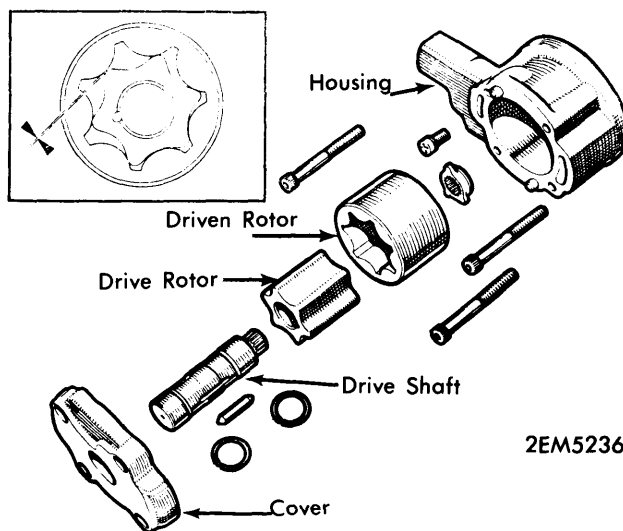

OIL PUMP ASSEMBLY

5) With rotors installed in pump body, measure tip clearance between rotor lobes. If clearance is in excess of .006", rotors must be replaced.

6) To install, reverse removal procedure.

ENGINE COOLING

WATER PUMP

1) Remove radiator and generator (alternator).

2) Remove fan and pulley. Remove hose from water pump inlet and loosen top clamp of by-pass hose.

3) Remove water pump mounting bolts and withdraw pump with by-pass hose.

4) To install, reverse removal procedure.

Thermostat – Three setting values are available: 180°F (standard), 165°F (hot climates) and 190°F (cold climates).

Cooling System Capacity – 4 quarts without heater and 4 3/4 quarts with heater.

TIGHTENING SPECIFICATIONS

Application	Torque (Ft. Lbs.)
Cylinder Head Stud Nuts.....	48-52
Additional Cylinder Head Bolt (9.75-1 Engine Only).....	25
Connecting Rod Bolts.....	35-38
Main Bearing Bolts.....	60-65
Flywheel Center Bolt.....	110-115
Cylinder Side Covers.....	2
Timing Cover 1/4" Bolts.....	4-6
Timing Cover 5/16" Bolts.....	10-14
Water Pump.....	14-18
Water Outlet Elbow.....	6-9
Manifold-to-Cylinder Head.....	12-16
Rocker Cover.....	3-4
Crankshaft Pulley.....	70-80
Drain Plug.....	25
Flywheel Housing Bolts & Stud Nuts.....	18