

GENERAL MOTORS — INTEGRAL WIPER/WASHER MOTOR

All Exc. "P" & "S" Models

DESCRIPTION

A 2-speed, permanent magnet type motor is used. It consists of field magnets, armature and drive gear enclosed within upper and lower housings. The washer pump is assembled on the outside surface of the upper half of the housing, and is an integral part of the wiper motor assembly. Wiper motor is protected by an automatic reset circuit breaker. Vehicle wiring is protected by a fuse in the fuse block.

OPERATION

The basic washer pump is a spring loaded piston enclosed in a plastic cylinder housing. An actuator plate extends from the cylinder housing. A valve assembly, consisting of 2 exhaust and 1 intake check valve, is attached to the end of the cylinder housing.

A tang on the piston actuator plate holds the plate in a lock-out position so there is no pumping action. To start the pump, push washer button to energize the relay. This pulls the relay armature toward the coil, allowing the ratchet gear pawl to engage the ratchet gear and begin rotation. This sequence starts pumping action.

TROUBLE SHOOTING

ALL MODELS

Wiper Inoperative

Check fuse, wiring harness, wiper ground and dash connections.

Wiper Will Operate at One Speed Only

Check for open wiring between terminals 2 or 3 and the dash switch. Check dash switch and if not operable, check "Low" and "High" brush leads.

Fig. 2: Washer Actuator Plate and Valve Assembly

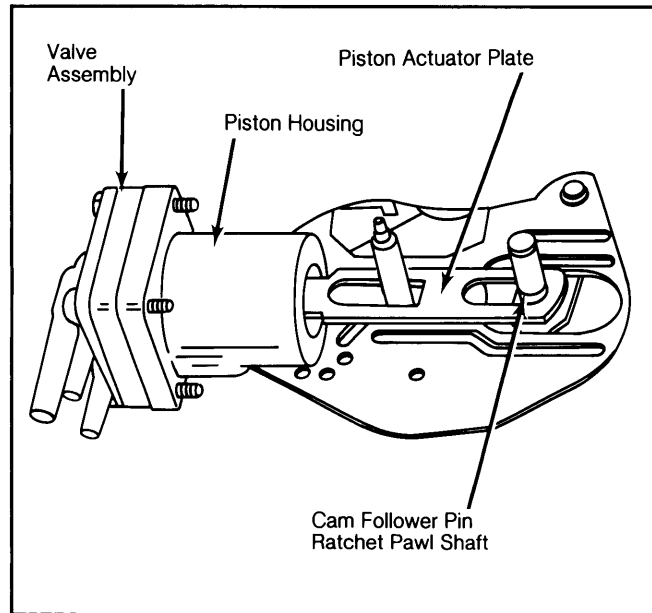

Wiper Blades Will Not Return To Park

Check for open wire from terminal 5 to dash switch. If not open, dash switch or wiper park switch should be replaced.

Fig. 1: General Motors Truck Wiper Motor & Integral Washer System Wiring Diagram

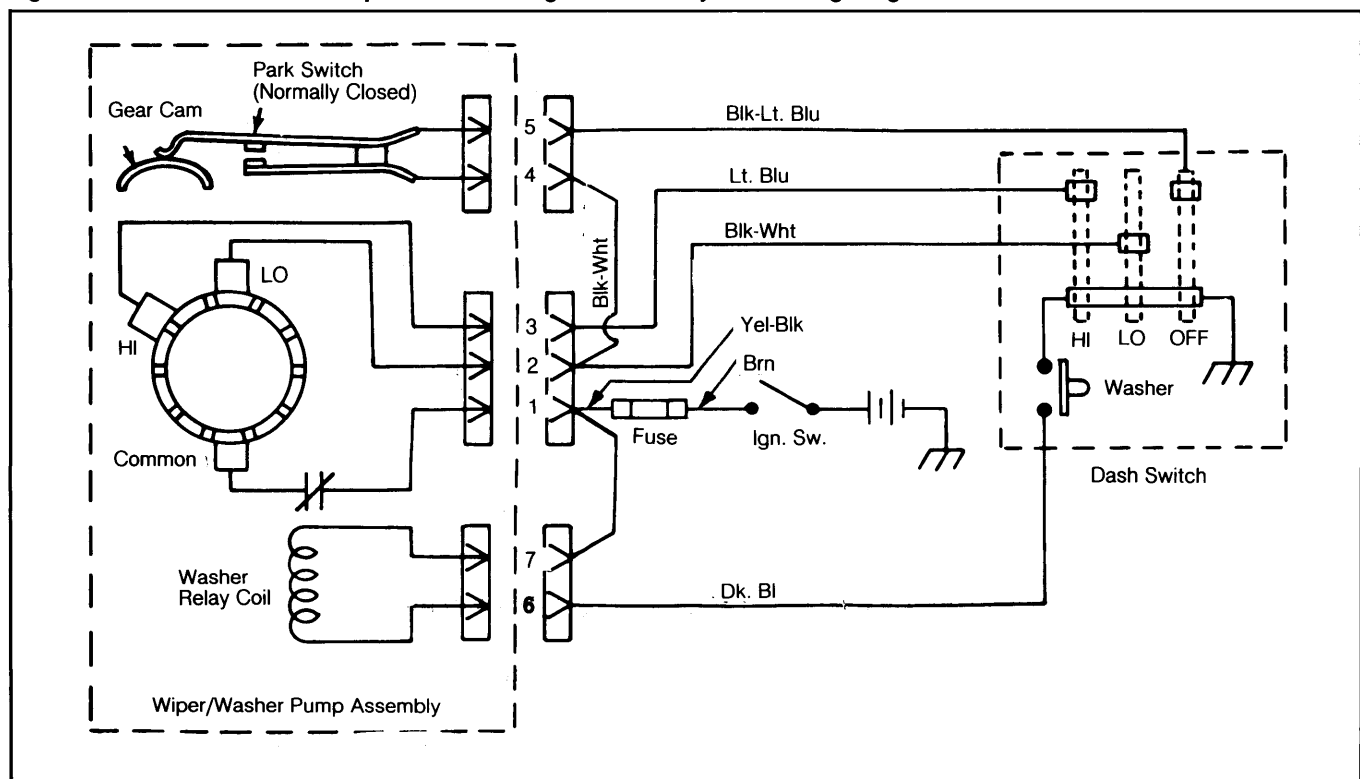

Wiper Washer Systems

GENERAL MOTORS — INTEGRAL WIPER/WASHER MOTOR

Wiper Will Not Shut Off

Disconnect wiring from terminals 4 and 5. Replace park switch assembly if motor stops. If motor still runs, remove wires from terminals 1, 2 and 3. Connect a 12 volt lead to terminal 1 only. If motor does not run it indicates a ground in wires from wiper motor to terminal 2 or 3 at dash switch. If it runs, check for internal ground in high or low brushes.

Washer Pump Will Not Run

Turn ignition switch to "ON" position. Make sure washer solution is adequate, then push wash button and listen for relay to energize. With ignition still "ON" and wiring connected to wiper terminals, connect test lamp lead to ground and probe terminals 6 and 7.

- If lamp is off at both terminals, check for open in circuit to the pump.
- If lamp is on at one terminal, replace coil-park switch assembly.
- If lamp is on at both terminals, but one lamp is dim, ground the dim lamp terminal. If pump runs, check for open in wire between pump and dash switch or for a defective dash switch.

NOTE: Delay wiper system is available as optional equipment. A separate control assembly is utilized which provides a variable delay of 1 to 20 seconds.

REMOVAL & INSTALLATION

WIPER MOTOR

Removal (Exc. "G" Models)

1) Make sure wiper motor is in park position.

Disconnect ground cable from battery, electrical harness

at motor and hoses at washer pump. Reach through access hole in cowl grille and loosen wiper drive rod attaching screws.

2) Remove drive rod from wiper motor crank arm. Remove wiper motor-to-dash panel attaching screws and remove motor assembly.

Installation

To install, reverse removal procedure. Lubricate crank arm pivot prior to installation.

Removal ("G" Models Only)

1) Make sure wiper motor is in park position. Disconnect battery ground cable and remove wiper arms. Remove cowl panel cover. Loosen nuts holding linkage to crank arm and lift linkage off arm. Disconnect wiring to motor. Remove left dash defroster outlet from flex hose and position hose to one side.

2) Remove screw securing left hand heater duct to engine cover shroud and slip heater duct down and out. Remove washer hoses. Remove screws securing wiper motor to cowl and lift wiper motor from under dash.

Installation

To install, reverse removal procedures. Ensure wiper motor is in park position before installing. Lube wiper motor crank arm pivot prior to installation.

OVERHAUL

Repairs to motor/gear box section of the wiper assembly are limited to the switch, armature, cap and brush holder assembly plus the external parts, crankarm, spacer/seal (plastic) and output shaft seal.

Fig. 3: Wiper/Washer Motor Terminal Check Diagram

