

CHRYSLER CORP.

All Models

DESCRIPTION

Standard 2-speed and intermittent wiper motors have permanent magnetic fields and are controlled by feeding power to different brushes for low and high speed. Motor speed is selected by rotating switch knob.

A 6-ampere circuit breaker is integral with wiper switch in protecting wiper system. Washer system is electrically operated and consists of an electric pump, sealed motor, reservoir, rubber hoses and nozzles.

NOTE: Wiper motors are basically the same. The intermittent wiper system does employ the following additions: Delay mode of 2-15 seconds, high speed is higher than standard, with a extra wipe after wash.

TROUBLE SHOOTING

WIPER SYSTEM

Wiper Inoperative

Binding linkage. Faulty wiper switch. Open or grounded wiring. Faulty motor.

Motor Runs But Output Crank Does Not Turn

Stripped intermediate gear or output gear. Output gear slips on output shaft. Crank arm not fastened properly to output gear shaft.

Motor Does Not Shut Off

Defective park switch.

Blades Will Not Park

Motor park switch open. Faulty instrument panel switch. Arm set at incorrect position. Open park wiring circuit.

Motor Will Not Run,

Circuit Breaker Does Not Cycle

Open circuit in wiring. Loose bulkhead connector. Motor not grounded. Faulty circuit breaker, instrument panel switch or motor.

Motor Will Not Run,

Circuit Breaker Cycles

Grounded wiring. Binding linkage. Faulty motor or instrument panel switch circuit breaker.

Motor Stops In Any Position

When Switch is Turned Off

Motor park switch open. Open park wiring circuit. Faulty instrument panel switch.

Motor Will Not Stop When Switch Turned Off

Defective park switch.

WASHER SYSTEM

Pump Runs But No Fluid Comes Out

No fluid in reservoir. Nozzle jet plugged or under intake grille. Broken hose or faulty pump.

System Operates Intermittently

Loose or faulty wiring connections. Faulty switch or motor.

System Output Low

Low aimed nozzles. Leaking hoses. Poor electrical connections. Defective motor.

Pump Motor Does Not Run

Broken wires. Faulty motor or switch. Poor ground. Loose wiring terminals.

TESTING

MOTOR WILL NOT RUN

1) Position panel switch in low-speed position. If motor can be heard running, check motor output shaft. If shaft is not turning, gearbox assembly requires replacement.

2) If the shaft is turning, check drive link to output shaft for worn parts or disconnected components. If motor cannot be heard running, connect a voltmeter or test lamp between motor terminal "L" and ground.

3) If voltage is present and panel switch circuit breaker is not cycling, check for open ground circuit. Ground strap must make good contact.

4) If motor runs, panel switch is not grounded, switch is faulty or there is an open in wiring. Common brush may not be making good contact with commutator and may require freeing-up or repositioning of spring. Armature may have an open circuit.

5) If voltage is present only part of the time, the circuit breaker is cycling. Problem may be a faulty circuit breaker or a short in the wiring, motor, or switch panel. Remove wiper arms and blades, disconnect harness at the motor and connect an ammeter between battery and terminal "L".

6) If motor runs with average ammeter reading below 6 amperes, motor is good and trouble is in switch panel or wiring. If motor does not run and draw is more than 6 amperes, check wiper linkage for binding. Disconnect drive link from motor. If motor runs and draws less than 3 amperes, repair linkage.

7) If motor fails to run or draws more than 3 amperes, check motor and gearbox for internal jamming. If no internal jamming exists, check motor for brush leads shorting to housing or armature for burned or blackened windings which could indicate an internal short.

MOTOR RUNS AT LOW SPEED ONLY

Position switch in high position and connect test lamp between terminal "H" and ground. If lamp does not light, an open exists in wiring or switch. If lamp lights, brush is not making contact with armature.

Fig. 1: Two Speed Intermittent Wiper Motor Terminals

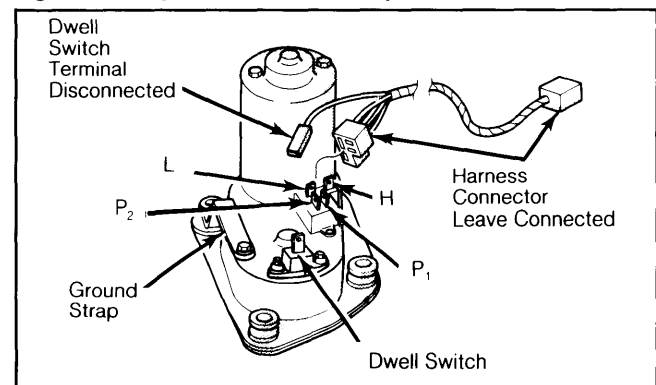

Standard terminal similar.

Wiper/Washer Systems

CHRYSLER CORP. (Cont.)

MOTOR RUNS AT HIGH SPEED ONLY

Position switch in low position and connect test lamp between terminal "L" and ground. If lamp does not light, an open exists in wiring or switch. If lamp lights at terminal "L", brush is not making contact with armature.

MOTOR CONTINUES TO RUN WITH SWITCH IN OFF OR PARK POSITION

Remove wiring harness and connect a jumper wire from terminal "P2" to terminal "L", then connect a jumper from "P1" to battery. If motor now runs to park position and stops, panel switch is defective. If motor continues to run and does not park, gearbox assembly requires replacement.

MOTOR WILL NOT STOP IN PARK POSITION WHEN SWITCH IS IN OFF POSITION

1) Remove wiring connector and clean terminals. If problem continues, place switch in park position and connect a voltmeter or test lamp between terminal "P₁" and "L". If 12 volts are present or test lamp lights, check for voltage at "P₂".

2) If voltage is zero or test lamp does not light, motor park switch is defective and must be replaced. If 12 volts are present or lamp lights, an open exists in panel switch or wiring.

2-SPEED WIPER SWITCH

1) Disconnect wiring from switch and remove switch from instrument panel. Use a continuity tester or ohmmeter to check for continuity between contact terminals of switch as shown in table.

2) For test purposes, first position is "OFF", "LOW" is first detent from "OFF" position and "HIGH" is second detent from "OFF" position. Ground is the case of wiper switch.

SWITCH CONTINUITY

Off	Low	High
B to B/U	B to B/U	B to B/U
B to P1	B to P1	B to P1
A to P2	B to A	B to H
H-Open	P2-Open	P2-Open
	H-Open	A-Open

Fig. 2: Chrysler 2-Speed Wiper Wiring Diagram

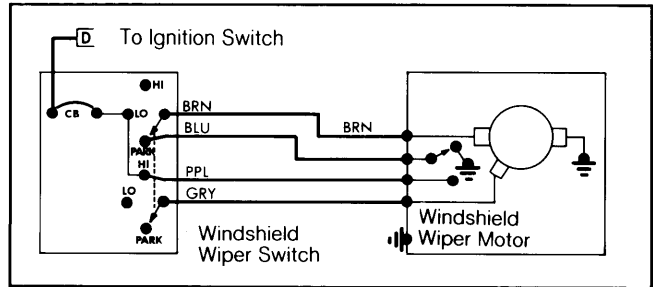

INTERMITTENT WIPER SWITCH

1) Disconnect wiring from switch and remove switch from instrument panel. Use a continuity tester or ohmmeter to check for continuity between contact terminals of switch as shown in table. For test purposes, first position is "OFF", next is position for "DELAY WIPE", "LOW" is first detent and "HIGH" is second detent.

2) Case of wiper switch is grounded. Resistance at maximum delay position should be between 270,000 ohms and 330,000 ohms. Resistance at minimum delay position should be zero with ohmmeter set on the high ohm scale. Positive lead of ohmmeter connected to "P₂" and negative lead connected to "G" should show low resistance.

Fig. 3: Chrysler Intermittent Wiper Wiring Diagram

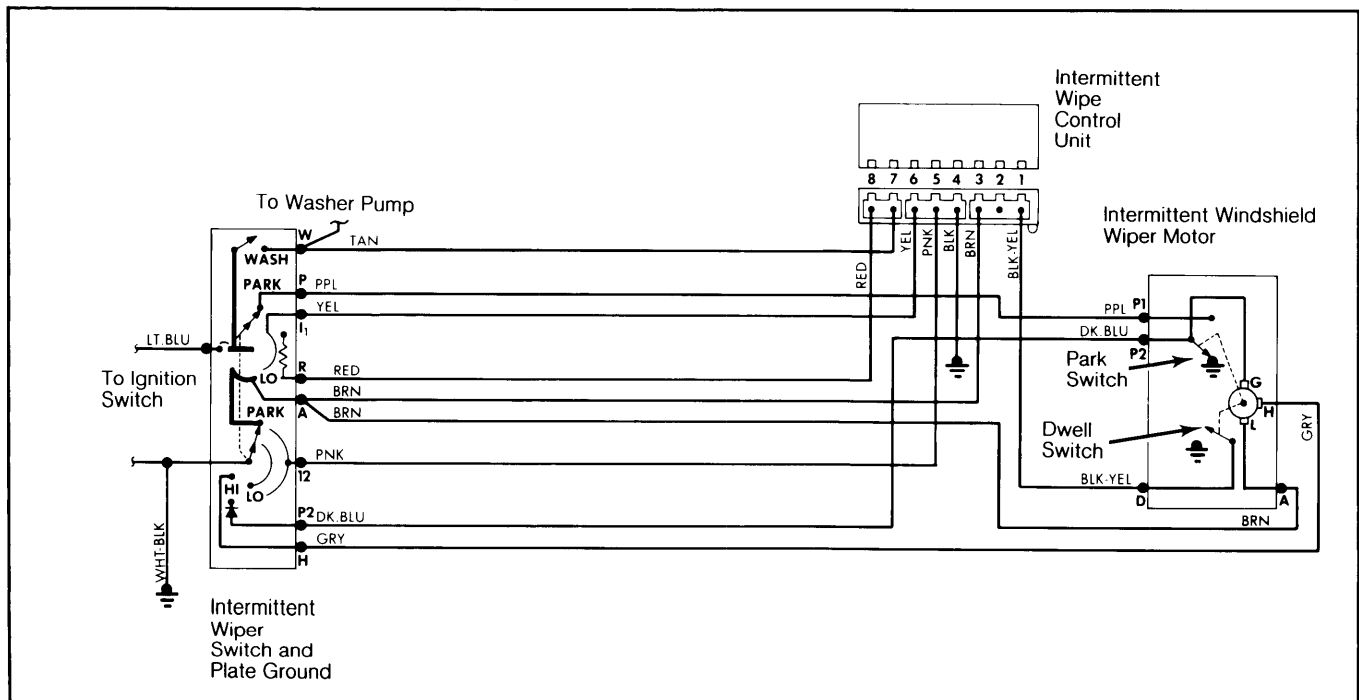

CHRYSLER CORP. (Cont.)

3) Negative lead of ohmmeter connected to "P₂" and positive connected to "G" should show an open circuit or very high resistance. If there is the same resistance in both minimum and maximum delay positions, switch is defective.

INTERMITTENT SWITCH CONTINUITY

Off	Delay	Low/High
B-P ₁	B-I ₁	B-A
A-G	R-I ₁	P ₂ -G
.....	P ₂ -G	¹ H-G

¹ — Measured on high scale.

REMOVAL & INSTALLATION

WIPER MOTOR

1) Disconnect battery cable, and wiring connector from motor and remove motor mounting screws. Lower motor far enough to gain access to crank arm-to-drive link retainer bushing.

2) Remove crank arm by prying retainer bushing from crank arm pin. Remove motor and nut attaching crank arm to motor drive shaft. Remove crank arm from motor. To install, reverse removal procedure.

WASHER PUMP

1) Drain fluid from reservoir. Remove reservoir mounting screws, reservoir and pump assembly. Disconnect electrical lead and rubber hose from bottom of pump.

2) Using an extension and deep socket, remove pump mounting nut and plastic washer by

reaching through reservoir neck. Remove pump and rubber grommet from reservoir. To install, reverse removal procedures.

OVERHAUL

WIPER MOTOR

Disassembly

Hold wiper motor in a vise and remove housing through bolts. Remove housing and armature assembly. Remove flat washers and spring washer.

Reassembly

1) Hold gear box in vise with brush holder up. Pull brushes back in brush slots and push brush lead into holding notch. Clean commutator with ink eraser. Install flat washer, spring washer and flat washer on armature shaft.

2) Place armature shaft in brush holder assembly. Release brush leads from brush holder notches, (ensuring that brushes are spring loaded against commutator). Align the window in the motor housing with the brush holder. Install housing quickly over armature so magnets do not pull armature out of brush holder.

3) Make sure motor housing is flush with gear housing and over the 4 detents. Install through bolts. Install part number tag and retaining screw. Bench test motor by connecting 12 volt power source. Connect positive lead in series with ammeter to terminal "L".

4) On 2-speed motor, ground the ground strap with a jumper wire. On intermittent wipe motors, connect a jumper wire from terminal "P2" to ground. On all models, tap the assembly gently with mallet to align bearings. Stop tapping when meter reads less than 2.5 amps. Install bulkhead seal.

Fig. 4: Chrysler Corp. Wiper Motor Exploded View

