

Turn Signals & Hazard Flashers

ALL MANUFACTURERS

DESCRIPTION

Turn signal and hazard flasher circuits are integral systems using a common switch assembly mounted within upper steering column housing. Signal lever is on left side of column and hazard switch knob is on right side.

Two different flasher units are used. The hazard flasher is a variable load type and will operate regardless of the number of lights burned out. If one signal light is burned out, signal circuit will not function on same side due to insufficient current draw to operate flasher. For wiring diagrams of individual models, refer to chassis wiring diagrams in WIRING DIAGRAM Section.

Fig. 1: Wiring Diagram of Typical Turn Signal and Hazard Flasher System

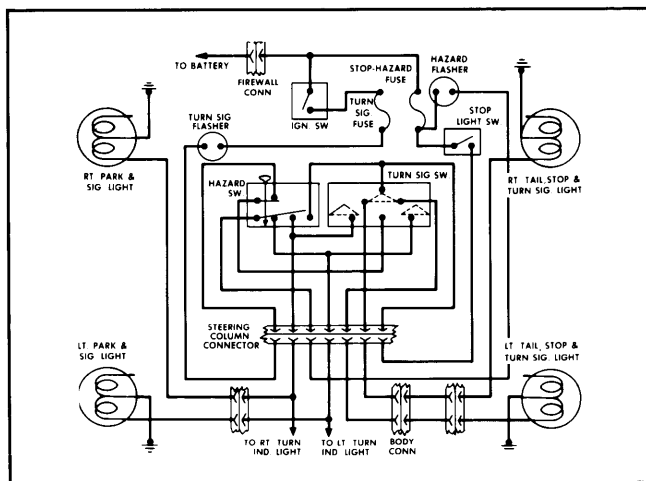

OPERATION

TURN SIGNALS

Signal systems operate only when ignition switch is turned on. Normal frequency of signal lights is about 60-120 flashes per minute. Switch has 2 detent positions for each signal direction.

With signal lever in first detent, lights will blink, but will go off if switch lever is released. Second switch detent will hold signal on, until steering wheel canceling fingers automatically turn signal off.

HAZARD FLASHER

With knob activated, all park and stop lights flash simultaneously regardless of ignition switch position. Depressing brake pedal will override flasher operation until pedal is released.

During hazard switch operation on Chrysler Corp. vehicles, the turn signal should be off to avoid creating electric feed back through accessory circuits. This could cause intermittent operation of circuits left turned on.

FLASHER LOCATION

CHRYSLER CORP.

Hazard

Located to the right of the fuse block on all models.

Turn Signal

Located to the right of the fuse block on all models.

FORD MOTOR CO.

Hazard

On "F" and Bronco models, under instrument panel to the left of steering column, on back side of fuse panel. On "E" models, in wiring harness near left side cowl.

Turn Signal

Located on fuse block on "F" and Bronco models, or on wiring harness near left side cowl on "E" models.

GENERAL MOTORS

Hazard

Mounted on the fuse panel.

Turn Signal

Located near fuse block at left of steering column on all models.

JEEP

Hazard

Mounted on the fuse panel.

Turn Signal

Mounted on the fuse panel.

TESTING & TROUBLE SHOOTING

TURN SIGNAL & HAZARD SYSTEM

Hazard Flasher Inoperative

1) Switch turn signals on. If signals operate, check hazard circuit fuse. Check power to hazard circuit fuse and test fuse. If fuse is blown, check for shorts and/or replace fuse. If fuse is satisfactory, check power to hazard flasher. Replace with a good flasher.

2) If system still fails, check power to hazard switch in steering column. Repair circuit between hazard flasher element and switch if necessary. To determine if switch is at fault, connect a known good switch in column to chassis connector and operate switch by hand. If hazard system now operates, repair or replace switch.

Turn Signals Inoperative

1) Turn on hazard system. If all lights operate, inspect for blown turn signal fuse or defective flasher. If fuse is blown, check for shorts between fuse and lamps. If turn signal fuse and flasher are satisfactory, check wire terminals in harness connector for continuity and power feed to and from switch.

2) To determine if switch is bad, connect a known good switch in column to chassis connector and operate switch by hand. If signals now operate, replace switch.

Turn Signals Inoperative (One Side)

1) Turn on hazard system. If one or more lights are inoperative, replace lights as necessary. Test light sockets for power or poor ground connection.

2) If all lights operate with hazard system on, inspect for improper lamp or inoperative turn signal switch. If turn signal flasher can be heard, but lights do not operate, check for a short circuit.