

Cruise Control Systems

FORD

Bronco, "E" & "F" Models

DESCRIPTION

Speed control system consists of "ON-OFF", "SET-ACCEL", "COAST", and "RESUME" switches, servo assembly, speed control sensor, clutch position sensor switch (man. trans.), amplifier, wire harness, vacuum dump valve, and vacuum hoses to connect components.

The switches are located in steering wheel spokes. The amplifier is located under the instrument panel, and the servo assembly is attached to the engine intake manifold. The speed sensor is located on the left side of the dash panel.

OPERATION

This system is operational at speeds over 30 MPH. When "ON-OFF" switch is actuated to "ON" position and "SET-ACCEL" switch is activated, the vehicle speed will be maintained until a new speed is set, the brake pedal is depressed, the clutch pedal is depressed (man. trans.), or the system is turned off.

The clutch position sensor switch (man. trans.) disengages the speed control, preventing engine over-speed when the clutch pedal is depressed.

To decrease set speed, apply brake and reset speed, using the preceding method, or depress the "COAST" switch. When the vehicle has slowed to the desired speed, release switch. The new speed is set into system.

To increase set speed, accelerate until desired speed is reached, then depress and release the "SET-ACCEL" switch. Speed may also be increased by depressing "SET-ACCEL" switch and holding in that position while vehicle automatically increases in speed.

When desired speed is reached, release switch and new speed will be set into system. When the speed control system is deactivated by depressing brake pedal, vehicle speed before system deactivation may be resumed by depressing "RESUME" switch.

Speed control memory of vehicle speed and "RESUME" switch will not function, however, if "OFF" switch is depressed, if ignition is turned off, or if vehicle speed drops below 30 MPH.

TESTING

NOTE: Horn and/or speed control may operate intermittently if ground brush is missing.

CONTROL SWITCH

1) Disconnect 6-way connector at amplifier. Check battery voltage at Light Blue/Black hash wire when "ON" switch is depressed. Battery voltage should be available from Light Blue/Black hash wire leading from control switches.

2) Connect an ohmmeter between Light Blue/Black hash wire and ground. Check wire for continuity to ground with "OFF" switch depressed. If resistance higher than 1 ohm is found, the wiring, slip rings or switch is at fault, or steering column may not be properly grounded.

3) To check steering column ground, connect an ohmmeter between a good body ground and steering column upper flange. Resistance should be less than ½ ohm. Rotate steering wheel, and check flexible coupling resistance. If resistance higher than 3 ohms is noted, clean horn brush contacts and ground brush.

4) A resistance less than 1 ohm must be obtained before performing the remaining tests. With ohmmeter connected between Light Blue/Black hash wire and ground, depress "SET-ACCEL" switch. A reading of approximately 680 ohms should be indicated on ohmmeter.

5) Depress "COAST" switch and a reading of approximately 120 ohms should be indicated on ohmmeter. Depress and hold "RESUME" switch. A reading of approximately 2200 ohms should be indicated.

SPEED SENSOR

1) Disconnect sensor wires from amplifier, and connect an ohmmeter between wire connector terminals (Dark Green stripe and Black on "E" models, Dark Green/White stripe and Black on Bronco and "F" models) at sensor end. A reading of about 40 ohms should be obtained.

2) A reading of "zero" ohms indicates a shorted coil. A maximum reading indicates an open coil. Replace sensor in either case. If reading is 40 ohms and speedometer operates properly, speed sensor is probably good. A new sensor can be substituted to check for proper operation.

SERVO ASSEMBLY

1) Disconnect ball chain from throttle linkage. Separate 8-way connector at amplifier, then connect an ohmmeter between the Orange/Yellow hash wire and Gray/Black hash wire at the connector. A resistance of 40-125 ohms should be obtained.

2) Connect ohmmeter between Orange/Yellow hash wire and White/Pink hash wire at connector. A resistance of approximately 60-90 ohms should be obtained. Reconnect the ball chain to carburetor. Start the engine with the servo-to-amplifier connector disconnected.

Fig. 1: Typical Servo and Bracket Installation

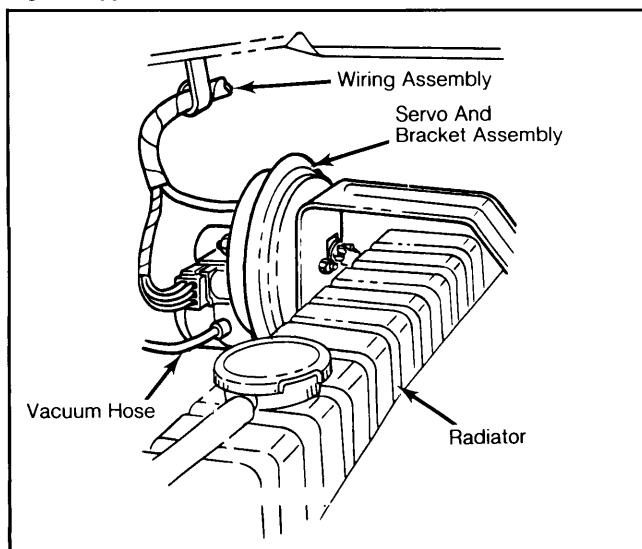

V8 with dual batteries shown, others similar.

FORD (Cont.)

3) Connect Orange/Yellow hash wire of servo to battery positive terminal. Connect White/Pink hash wire to ground, and then momentarily touch Gray/Black hash wire of servo to ground. Servo throttle actuator should tighten bead chain and open throttle.

4) Throttle should hold in that position or slowly release tension on chain. When White/Pink hash wire is removed from ground, servo should release bead chain tension immediately. If servo fails any of the preceding tests, replace the servo.

5) If Orange/Yellow hash wire is shorted to either White/Pink hash wire or Gray/Black hash wire, it may be necessary to replace amplifier.

AMPLIFIER

CAUTION: DO NOT use a test light to perform amplifier tests, as excessive current draw will damage electronic components. Use only a voltmeter of 5000 ohm/volt rating or higher.

“ON” Circuit Test

1) Turn ignition “ON”, and connect a voltmeter between ground and Light Blue/Black hash wire at amplifier 6-way connector. Voltmeter should read 12 volts when “ON” switch in steering wheel is depressed and held. If no voltage is available, conduct Horn Relay Circuit Test and Control Switch Test.

2) Release “ON” button. A 7.8 volt reading should remain on voltmeter indicating the “ON” circuit is engaged. If voltage does not remain, check for ground at amplifier, fuse and/or circuit breaker. Insert a known good amplifier and recheck “ON” circuit if necessary.

“OFF” Circuit Test

1) With ignition “ON” and voltmeter connected to Light Blue/Black hash wire at amplifier 6-way connector, depress the “OFF” switch on steering wheel. Voltage should drop to zero indicating “ON” circuit is de-energized.

2) If voltage does not drop to zero, perform Control Switch Test. If switches test good, install a known good amplifier and retest.

“SET-ACC” Circuit Test

1) With ignition “ON” and voltmeter connected to Light Blue/Black hash wire at amplifier 6-way connector, depress the “ON” switch, then hold “SET-ACC” button on steering wheel.

2) Voltmeter should indicate approximately 4.5 volts. Rotate steering wheel, and watch voltmeter for variation. If voltage varies more than .5 volts, perform Control Switch Test.

“COAST” Circuit Test

1) With ignition “ON” and voltmeter connected to Light Blue/Black hash wire at amplifier 6-way connector, depress the “ON” switch and hold “COAST” button down on steering wheel.

2) Voltmeter should indicate about 1.5 volts. If all functions check good, perform Servo Assembly Test. Insert a known good amplifier, and recheck system if necessary.

NOTE: DO NOT substitute a new amplifier until actuator coils have been tested. See Servo Assembly Test.

Fig. 2: Wiring Diagram of Ford Automatic Speed Control System

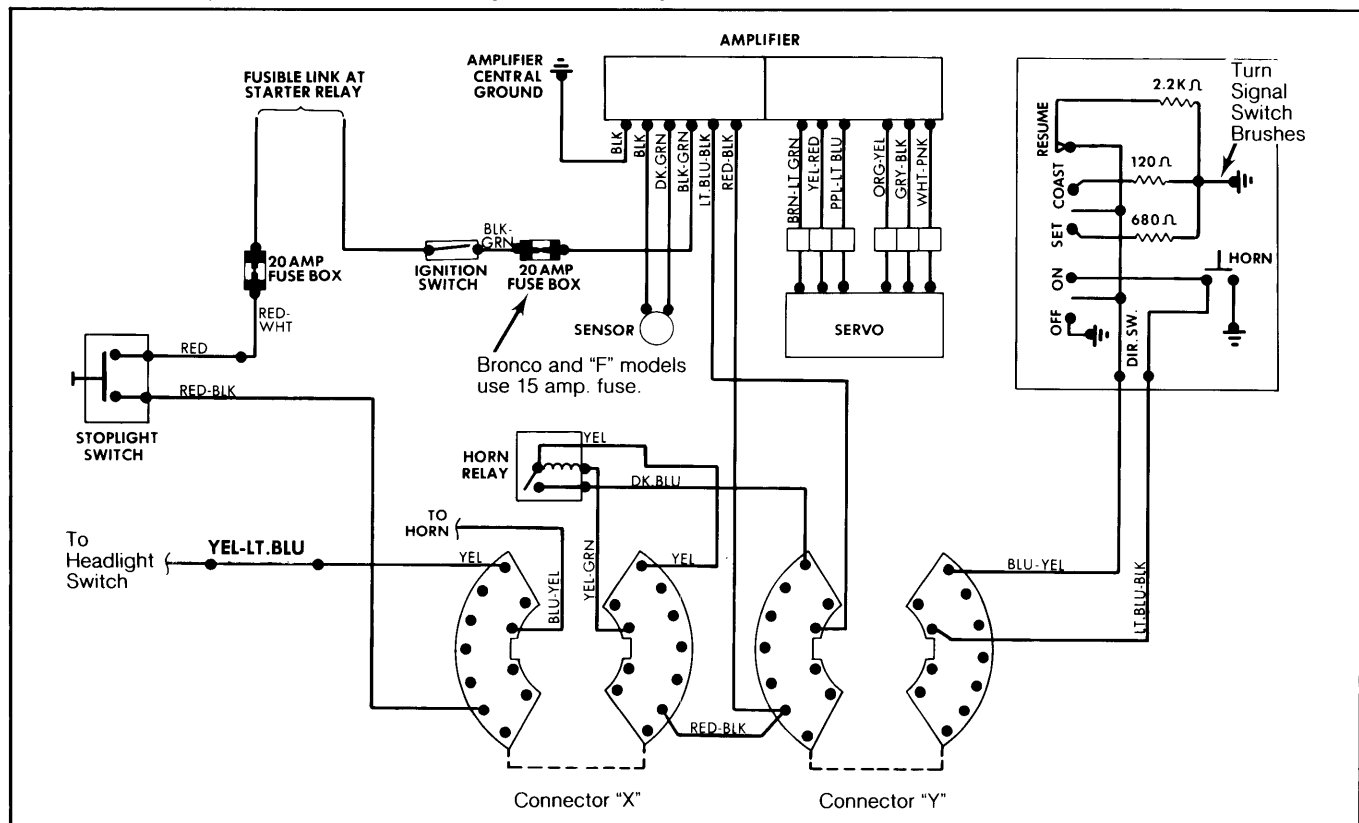

"E" model diagram illustrated.

Cruise Control Systems

FORD (Cont.)

"RESUME" Circuit Test

1) With ignition "ON" and voltmeter leads connected to ground and to Light Blue/Black hash wire at amplifier 6-way connector, depress and hold "RESUME" switch. Voltmeter should indicate approximately 6.5 volts.

2) If all functions check good, perform Servo Assembly Test. Insert a known good amplifier, and recheck system if necessary.

HORN RELAY CIRCUIT TEST

NOTE: Electrical connectors must remain connected during horn relay testing.

1) Locate yellow wire ("E" models) or Yellow/Light Blue dot wire (Bronco and "F" models) at connector "X". Check for battery voltage on pin side of connector. See Fig. 2.

2) Locate Blue/Yellow stripe wire ("E" models) or Dark Blue wire (Bronco and "F" models) at connector "Y". Check for battery voltage on socket side of connector. With voltmeter still connected to socket, depress horn switch.

3) Horn should sound, but voltmeter should indicate "zero" volts. If voltmeter still indicates battery voltage when horn switch is depressed, check horn switch or steering column wiring for an open circuit.

4) To by-pass horn switch and check horn relay, momentarily ground Blue/Yellow stripe wire ("E" models) or Dark Blue wire (Bronco and "F" models) on socket side of connector "Y".

5) If horn still does not sound, check Yellow/Green stripe wire ("E" models) or Yellow/Light green wire (Bronco and "F" models) at connector "X" for battery voltage while relay is activated. If battery voltage is present when relay is activated, an open circuit is present between connector "X" and horn.

6) If battery voltage is present in step 1) and horn relay failed to operate in step 3), replace relay.

CLUTCH SWITCH TEST

Bronco & "F" Man. Trans. Models

NOTE: Switch operates magnetically. Do not use magnetized tools near switch. Use only a voltmeter of 5,000 ohm/volt rating or higher to test switch. Test lamp will not indicate switch condition.

1) Check if clutch switch plunger is depressed (switch closed) when clutch pedal is released. Speed control will not operate unless this condition exists.

2) Disconnect clutch switch connector from speed control harness connector, and connect an ohmmeter to switch connector terminals. With clutch pedal released in "full-up" position and switch plunger depressed (switch closed), resistance should be less than 5 ohms.

3) With clutch pedal depressed and switch plunger fully extended (switch open), resistance should be "infinity".

BRAKE STOP LIGHT SWITCH & CIRCUIT TEST

NOTE: This test should be performed whenever brake application will not disengage speed

control. If both stop lights are not working it will cause speed control malfunctions.

1) Check for stop light operation with a maximum brake pedal effort of 6 lbs. (2.7 kg). Check brake pedal actuation and stop light switch if pedal effort required is excessive. If stop lights operate correctly, check battery voltage at Black/Green stripe wire at 6-way connector.

2) Depress pedal until stop lights are on. Check voltage at Red/Black stripe wire at 6-way connector. If voltage readings differ by more than 1.5 volts, high resistance exists in stop light circuit and must be corrected. If stop lights do not work, the stop light switch, supply circuit and bulbs must be checked for correct operation.

VACUUM DUMP VALVE TEST

1) Vacuum dump valve should be checked whenever brake application does not release speed control. Disconnect vacuum hose from the dump valve to the servo at the servo. Connect hand vacuum pump to hose and pump up a vacuum.

2) If vacuum cannot be obtained, the hose or dump valve leaks and should be replaced. Depress brake pedal. Vacuum should be released. If not, adjust or replace dump valve.

ADJUSTMENT

LINKAGE ADJUSTMENT

1) Adjust bead chain to obtain .06-.25" (1.6-6.4 mm) actuator arm free travel when engine is at hot idle. Adjustment should be made to eliminate as much slack as possible without restricting carburetor lever from returning to idle.

2) Cut off chain in excess of 4 beads. On vehicles equipped with solenoid anti-diesel valve, perform this adjustment with ignition switch in "OFF" position.

VACUUM DUMP VALVE ADJUSTMENT

1) Check that brake pedal is against stop in "released" position. Move dump valve forward in retaining clip until $\frac{1}{8}$ " (3.2 mm) or less of valve plunger is exposed.

2) Tip of valve plunger should contact brake pedal adapter. Check again if brake pedal is against stop in "released" position. Step on brake pedal. If vacuum still does not release, replace vacuum dump valve.

Fig. 3: Vacuum Dump Valve Adjustment

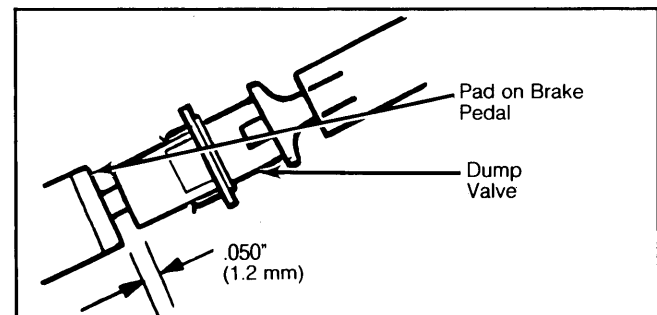

Valve black housing must clear white plastic on brake pedal pad.