

JEEP TAILGATE

Cherokee & Wagoneer

DESCRIPTION

A heated tailgate window defogger system is available on Cherokee and Wagoneer models. The system consists of 2 vertical bus bars and horizontal rows of heating elements fused to inside of glass, a control switch, indicator light, and timer relay.

Braided wire serves as the electrical feed and ground for the grid. The grid feed wire is attached to the timer relay located inside tailgate. The timer relay receives its power from the fuse panel power tailgate terminal. A 30-ampere circuit breaker protects the circuit.

OPERATION

A separate control circuit, connected to the heater control switch, operates the relay and timer. With the control switch on instrument panel and ignition switch "ON", the defogger relay contacts close.

A timer enclosed in the relay case will allow the defogger to operate for about 8 to 12 minutes, depending upon ambient temperature, or until the control switch or ignition switch is turned "OFF". An indicator light on the instrument panel is on when the system is in operation.

NOTE: The defogger switch and electric tailgate switch are serviced as an assembly.

Fig. 1: Wiring Diagram for Jeep Rear Window Defogger

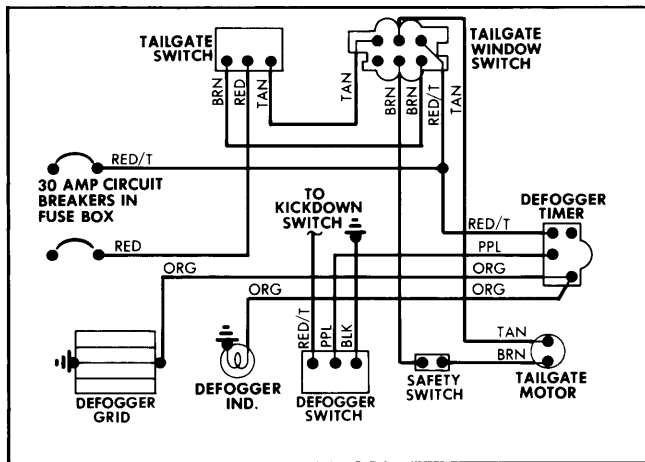

TESTING

CONTROL SWITCH

Turn ignition switch "ON", and press defogger switch. Separate wiring harness at connector under dash. Connect a 12-volt test lamp from Purple wire to ground. Test lamp should light. Turn defogger switch "OFF". Test lamp should not light.

INDICATOR LIGHT

Disconnect Orange wire from lamp. Connect jumper wire from accessory terminal to Orange wire. With ignition turned to "ACCESSORY", lamp should light.

RELAY

1) Attach negative lead of voltmeter to ground. Touch Red wire with voltmeter positive lead. Battery voltage should be indicated. If no voltage is indicated, operate tailgate window.

2) If window operates, the wire between the relay and window switch is open. Touch Orange wire with voltmeter positive lead. No voltage should be indicated. Turn ignition switch "ON". Voltmeter should indicate voltage. If not, relay is defective or not receiving voltage from Purple wire.

3) If relay operates properly, it should remain energized for 8 to 12 minutes before opening. If time period is too short or long, relay is defective. If relay did not energize, connect a jumper wire to a known good 12-volt source in tailgate and touch relay Purple terminal.

4) If relay clicks, trace Purple wire for open or short. If relay does not click, check relay ground. If ground is satisfactory, replace relay.

GRID

1) Use a 12-volt voltmeter, and connect positive lead to right (Feed) side of vertical element on inside of glass. Connect negative lead to left side of vertical element. Voltage should read 11 to 13 volts with ignition "ON".

2) Connect negative lead to ground, disconnect positive lead and touch each grid at center of window.

3) Voltage drop of 6 volts indicates good grid. Voltage drop of 12 volts at center indicates a break in grid between positive lead and ground. No voltage drop at center indicates break in grid between center and feed wire.

4) Exact location of break can be located by moving positive lead to left or right until an abrupt change in voltage is noticed. Repair to grid can then be made.

Fig. 2: Voltmeter Connections and Voltage Drop for Grid Continuity

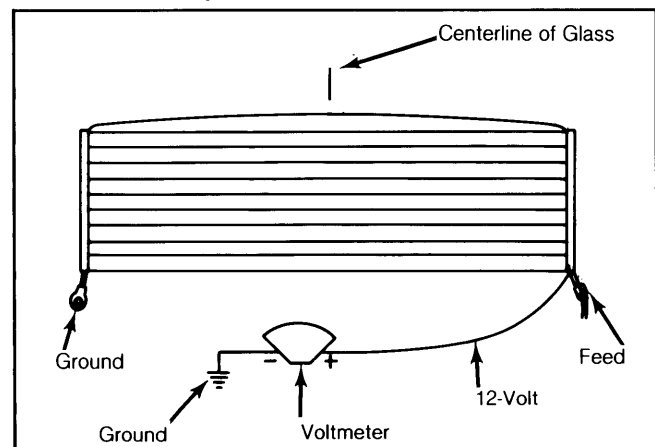

Abrupt voltage change indicates location of break.