

Defoggers

CHRYSLER CORP. REAR WINDOW

Van Models

DESCRIPTION

Heated rear window system, available for van models, consists of 2 bus bars, heating elements baked on inside of glass, a control switch, 25-ampere fuse, and a continuous or timed relay.

OPERATION

With ignition and control switch turned "ON", continuous relay will remain on until ignition or switch is turned "OFF". Timed relay will operate 8½ to 11½ minutes. Relay is mounted to right of switch on lower dash panel. An indicator lamp on dash glows when system is in operation.

Fig. 1: Rear Window Defogger Wiring Diagram

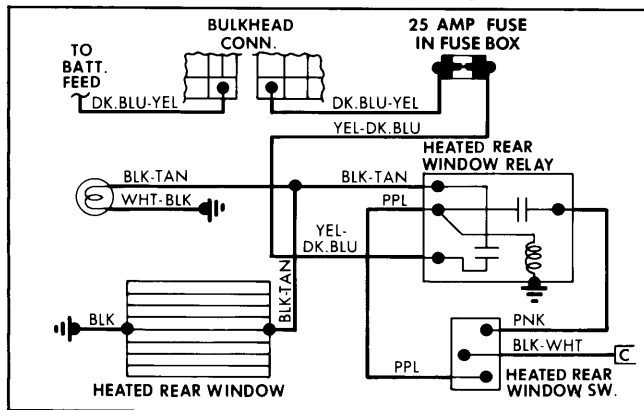

TESTING

CONTROL SWITCH

Turn ignition switch "ON", and move control switch to "ON" position. Connect a 12-volt test lamp from Purple wire to ground. Lamp should light. When switch moves to normal position, lamp should stay on. Turn switch to "OFF" position. Lamp should go off.

INDICATOR LIGHT

Disconnect Black/Tan wire from indicator light. Connect jumper wire from "ACC" terminal to Black/Tan wire. Turn ignition to "ACC". Bulb should light.

RELAY

1) Remove relay. On continuous relay, ground housing. On timed relay, ground terminal "G". Connect jumper wire from terminal "B" (Yellow/Dark Blue wire) to terminal "Y" (Pink wire). Connect a 12-volt test lamp from terminal "L" (Black/Tan wire) of relay to ground.

2) Apply 12 volts to terminal "B" (Yellow/Dark Blue wire). Test lamp should not light. If lamp comes on, replace relay.

3) Short terminal "B" (Yellow/Dark Blue wire) and terminal "P" (Ground wire) for a few seconds. Lamp should light and stay on for 8½ to 11½ minutes on timed relays and until turned off on continuous relays. If lamp does not light, replace relay.

Fig. 2: Relay Terminals

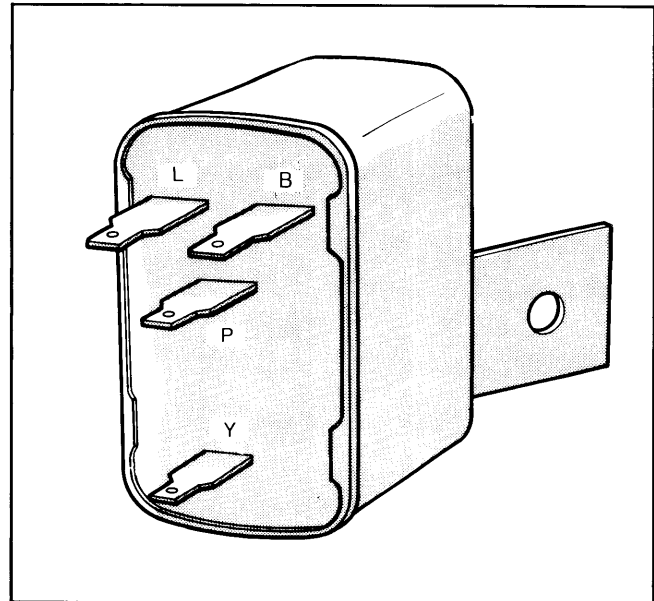

GRID

1) Using a DC voltmeter with a 0-15 volt range, contact bus bar connecting grid lines on right (Feed) side of glass with negative lead of voltmeter. Contact left bus bar with positive lead.

2) Turn ignition and control switches "ON". Voltmeter should read 10-14 volts. Lower voltage indicates a poor ground. With negative lead, contact a good ground. Voltage reading should not change.

3) Contact negative lead to left side bus bar. Touch each grid line at midpoint with positive lead. A 6-volt reading indicates line is good. A reading of 0 volts indicates a break in line between midpoint and right bus bar.

4) A 10-14 volt reading indicates a break between midpoint and left bus bar. Move positive lead toward break and voltage will change when break is crossed.

Fig. 3: Voltmeter Connection for Grid Continuity

