

# Starters

## CHRYSLER CORP. GEAR REDUCTION

Dodge, Plymouth

### DESCRIPTION

The starter motor consists of 4 series parallel fields, 4 brushes and a solenoid-shifted, overrunning clutch. The starter has a 3.5 to 1 reduction gear set, built into the starter assembly, and located in a die cast aluminium housing. The starter consists of 2 separate circuits: The supply circuit which provides the heavy current to motor and control circuit which activates solenoid.

### TESTING

#### STARTER CONTROLS

**NOTE:** Test solenoid and relay in order as described. Before performing test, disconnect coil wire from distributor cap and secure to a good ground to prevent engine from starting.

#### Starter Solenoid

Connect a heavy jumper wire on starter relay between battery and solenoid terminals. If engine cranks, solenoid is good. Proceed to starter relay test. If engine does not crank or solenoid chatters, check wiring and connections from relay to starter for loose or corroded connections. Repeat test and if starter still fails to crank, starter must be removed for repairs.

#### Starter Relay

1) Position automatic transmission gear selector in "N" or "P" position and manual transmission in Neutral. Connect a jumper wire on starter relay between battery and ignition terminals.

2) If engine cranks, starter relay is good. If engine does not crank, connect a second jumper wire to starter relay ground terminal and a good ground. If engine still does not crank, replace starter relay.

3) If engine does crank, relay is functioning, transmission linkage is out of adjustment (automatic transmission) or neutral safety switch is defective (automatic transmission) or there is a poor ground between relay housing and its mounting surface.

#### CRANKING CIRCUIT RESISTANCE TEST

1) Make the following tests with engine cranking and all terminals connected. Connect a voltmeter at the following locations:

- Positive lead to battery positive post and negative lead to battery terminal on starter.
- Positive lead to starter housing and negative lead to negative post on battery.
- Positive lead to engine block and negative lead to battery ground cable.

2) Each of these 3 connections should show a voltmeter reading of .2 volt or less. If reading exceeds .2 volt, clean or repair cables and connections in circuit.

Connect a voltmeter at the following locations:

- Positive lead to battery positive post and negative lead to cable clamp.
- Positive lead to battery negative post and negative lead to cable clamp.

3) If reading is other than zero on voltmeter, clean or repair cables and connections in circuit.

#### AMPERAGE DRAW TEST

**NOTE:** Engine should be up to operating temperature before performing this test. Heavy oil or a tight engine will increase starter draw amperage.

1) Connect a battery-starter tester and a remote starter jumper, both according to manufacturer's instructions. Turn variable resistor control knob to off or zero position. Crank engine long enough to read cranking voltage on voltmeter.

**NOTE:** Do not crank engine excessively, or starter may overheat.

2) Without cranking engine, turn variable resistor control knob on tester until voltmeter reads cranking voltage of previous test. With same voltmeter reading indicated, amperage reading will be equivalent to starter amperage draw test. See *Starter Specifications*.

#### SOLENOID WINDINGS

1) Connect solenoid to a 6 volt DC power supply with an ammeter in series. Connect positive lead of power supply to solenoid terminal and positive lead of ammeter to solenoid sleeve.

2) Connect negative lead of power supply to other ammeter terminal. Turn current on and check draw against hold-in specifications. Check pull-in coil the same way, except connect positive ammeter lead to solenoid lead terminal.

3) Check draw against specifications. If either winding does not meet specifications, or if winding looks burnt or damaged, replace solenoid assembly.

#### NO LOAD TEST (ON BENCH)

Connect a test ammeter and carbon pile rheostat in series with battery positive post and starter terminal. Connect a voltmeter across starter. Rotate carbon pile to full resistance position. Connect battery cable from battery negative post to starter frame. Adjust rheostat until battery voltage shown on voltmeter reads 11 volts. Amperage draw should be as shown in specifications.

#### LOCKED RESISTANCE TEST

Mount starter in test bench. Follow test equipment manufacturer's instructions. With battery voltage adjusted to 4 volts, amperage draw should be as shown in specifications.

#### STARTER SPECIFICATIONS

Application	Amps
Amperage Draw Test	
3.7L and 5.2L .....	165-180
5.9L .....	180-200
Solenoid Winding Test (6 Volts @ 77°F)	
Pull-In Circuit .....	13-15
Hold-In Circuit .....	8-9
No Load Test (11 Volts @ 3700 RPM Minimum) ....	90
Locked Resistance Test (4 Volts) .....	475-550

## CHRYSLER CORP. GEAR REDUCTION (Cont.)

### OVERHAUL

#### DISASSEMBLY

1) Remove through bolts and end head assembly. By pulling outward, remove armature from gear housing and field frame assembly. Carefully pull field frame assembly from gear housing just far enough to expose terminal screw. Remove terminal screw, completely remove field frame assembly.

2) Remove nuts and separate solenoid and brush plate assembly from gear housing. Remove nut, steel washer and sealing washer from solenoid terminal. Unwind solenoid lead wire from brush terminal. Remove screws attaching solenoid to brush plate. Remove solenoid from brush plate.

3) On brush plate, remove nut from battery terminal and remove terminal. From solenoid, remove solenoid contact and plunger assembly. Remove return spring from inside of solenoid moving core.

4) Remove dust cover from gear housing. Release retainer clip that positions driven gear on pinion shaft.

**CAUTION: Retainer is under tension. Place cloth over assembly to catch it as it flies off.**

5) Remove pinion shaft "C" clip. Push shaft toward rear of housing, remove retainer ring and thrust washers. Remove clutch and pinion assembly. Remove the 2 shift fork nylon actuators as an assembly.

6) Remove driven gear and friction washer. Pull shifting fork forward and remove solenoid moving core. Remove shifting fork retainer pin and shifting fork assembly.

**Fig. 1: Chrysler Corp. Shift Fork & Clutch Assembly**

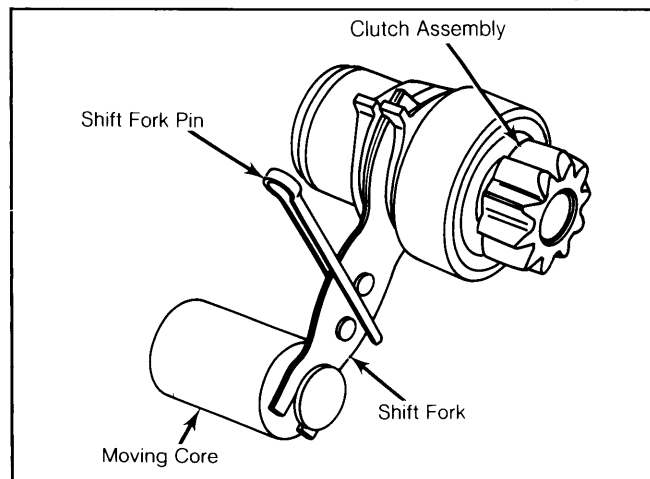

Remove shift fork assembly by removing retainer pin.

### PARTS REPLACEMENT & TESTING

#### Brushes and Springs

Replace brushes if oil soaked or worn more than 1/2 length of new brushes. When soldering solenoid lead, use high temperature solder and resin flux. Measure spring tension with spring scale attached under spring near end. Pull on line parallel to edge of brush and note reading just as spring end leaves brush. Replace if tension is not within specifications.

### SPRING TENSION

Application	Tension
All Models .....	32-36 ozs. (907-1021 g)

#### Starter Shaft Bushings

Inspect bearing surfaces for wear. Insert starter shaft into bushing and check for side play. Replace end head if its' bushing is worn. Replace other bushings, using a puller (C-3944). Service bushings are pre-sized and do not require burnishing or reaming.

#### Starter Clutch Unit

Pinion should rotate smoothly in 1 direction (not necessarily easy) and should not rotate in opposite direction. If not functioning properly, or if pinion is worn, chipped or burred, replace assembly.

**CAUTION: Do not immerse in cleaning solvent, as the unit is pre-lubricated and lubricant will wash out.**

#### Armature

Check for shorted armature coils in growler. Check for grounded coils by touching 1 test light probe to armature shaft and other probe to each commutator bar. Lamp should not light. If lamp lights, armature coils are grounded and armature must be replaced. Commutator should be smooth and clean, and runout must not exceed .004" (.10 mm). If runout is excessive, reface in a lathe.

#### Field Coil Assembly

With field frame removed from starter, drill out rivet attaching field coil lead and shunt coil lead to frame, insulate leads from frame. Test for ground with 110V test lamp by touching 1 probe to field coil lead and other probe to field frame. Lamp should not light, if lamp lights, field coils are grounded. Replace field coils and field frame as an assembly.

### CLEANING

Do not immerse parts in cleansing solvent. Clutch outer housing and pinion gear may be cleaned with a cloth moistened with cleaning solvent and then wiped dry. Clean all corrosion from solenoid assembly and inside of solenoid housing. Clean terminal contacts and contactor with crocus cloth.

### REASSEMBLY

1) Ensure that shift fork plates have approximately 1/16" side movement. Lubricate sparingly between plates with SAE 10 engine oil. Position shift fork in housing, bend 1 tip of pin at a 15° angle away from housing. Fork and retainer pin must operate freely after tip of pin is bent. Install solenoid moving core and engage shifting fork.

2) Start pinion shaft into drive housing. Install friction washer and drive gear, clutch and pinion assembly, thrust washer, retaining ring and thrust washer. Shift fork must engage clutch actuators properly and friction washer must be positioned on shoulder of pinion shaft splines before driven gear is positioned.

3) Install driven gear, retainer clip, pinion shaft "C" clip and starter solenoid return spring into bore of movable core. Install solenoid contact plunger assembly into solenoid. Contact spring must be positioned on shaft of solenoid contact and plunger assembly.

# Starters

## CHRYSLER CORP. GEAR REDUCTION (Cont.)

4) Assemble battery terminal stud in brush holder. Position seal on brush holder plate. Start solenoid lead wire through hole in brush holder. Install solenoid stud, insulating washer, flat washer, and nut.

5) Wrap lead wire tightly around brush terminal post. Solder with high temperature resin core solder and resin flux. Install brush holder to solenoid attaching screws. Install solenoid coil and brush plate assembly into starter gear housing. Install and tighten nuts.

6) Install armature thrust washer in brushes with brushes resting on washer tabs (washer will hold brushes out and facilitate armature installation). Install brush terminal screw. Position field frame in correct position on gear housing and install armature in field frame and gear housing.

7) Carefully engage splines of shaft with reduction gear by rotating armature slightly. Install thrust washer on armature shaft. Position starter end head assembly and tighten through bolts securely.

**Fig. 2: Exploded View of Reduction Gear Starter**

