

JEEP

All Models

DESCRIPTION

Jeep vehicles use a two-speed electric motor which is a compound wound (series and shunt) type. A crank arm is attached externally to gear shaft and operates linkage which activates the wiper blades. All models except "CJ" and Scrambler have an optional intermittent feature. All models use an electric washer system which consists of a motor, reservoir and necessary hoses and nozzles. The pump assembly is mounted in the bottom of the reservoir. The motor case is grounded to the vehicle body and is energized by a feed wire from the control switch.

TESTING & TROUBLE SHOOTING

2-SPEED WIPER (ON VEHICLE) "CJ" & SCRAMBLER MODELS

NOTE - The wiper motor must be grounded for proper operation and during all of the following test procedures.

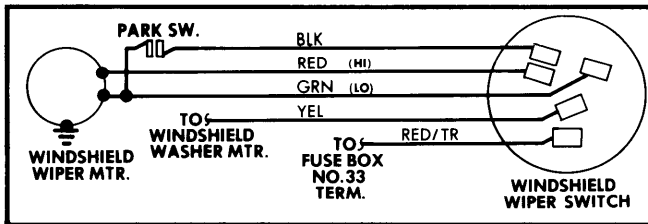

Fig. 1 Jeep 2-Speed Wiper System Wiring Diagram ("CJ" & Scrambler Models)

1) Place ignition switch in "ON" position and use a suitable test lamp to check for 12 volts at switch terminal B. See Fig. 2. If test lamp lights but motor does not operate, ensure ground is

good by connecting a jumper wire from motor ground strap to a good body ground. If motor still will not operate, disconnect jumper wire. Disconnect wiring from switch.

2) Connect a jumper wire between terminals number 2 and B which should give low speed operation of motor. If motor does not operate on low speed, possible causes are an open condition in green wire leading from switch, a loose internal connection in motor or a stuck low speed brush.

3) Connect a jumper wire between terminals number 3 and B which should give high speed operation of motor. If motor does not operate on high speed possible causes are an open condition in red wire leading from switch, a loose internal connection in motor or a stuck high speed brush.

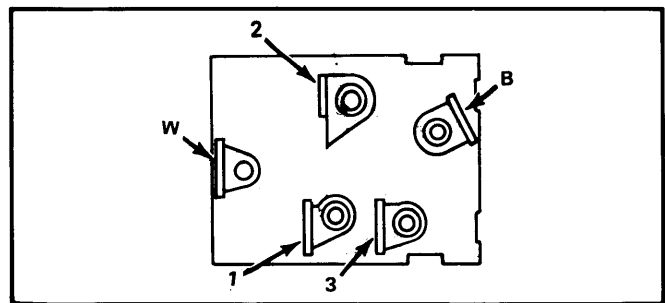

Fig. 2 Jeep Identification of Test Connections ("CJ" & Scrambler Models)

4) Position wiper blades in a position other than park and connect a jumper wire between terminals number 1 and B. Motor should run on low speed and stop with blades in park position. If motor does not run with jumper connected, possible causes are an open in black wire from switch, a loose internal connection in motor, a bad connection between park point set to low speed brush, or a misaligned or damaged set of con-

WIPER SWITCH CONTINUITY TEST

	Standard	Intermittent
Off or Park	1-2 3-4	1-2 4-5
Low Speed	1-2-3	1-2 4-5 to Case 4-5
High Speed	1-2-5	1-2-3 4-5 to Case 4-5
Intermittent		1-2 4-5 to Case 4-5 Variable Resist. 1.9K to 7 K
Wash	1-2 6-7	1-2 6-7

MOTOR CURRENT DRAW TEST

Check to Be Sure Motor is Grounded

CIRCUIT BREAKER TEST

Fig. 3 Testing Wiper/Washer System (Cherokee, Wagoneer & "J" Models)

JEEP (Cont.)

tact points. If motor runs but does not position wipers in park position, cam on drive gear is not breaking contact points sufficiently.

2-SPEED WIPER (ON CAR) CHEROKEE, WAGONEER & "J" MODELS

Wiper Inoperative or Operates at One Speed Only – Foreign objects interfering with linkage. Open circuit in ignition switch, wiper switch, harness or terminals. Loose or misaligned connection between wiring harness plug and motor plug. Faulty ground strap connection.

Wipers Do Not Park – Disconnect wiper motor and connect black lead to white lead and feed 12 volts to red lead. Replace motor if it fails to park. If it parks, turn ignition switch "ON" and wiper switch to "PARK". Connect test light to pink wire with tracer (at motor plug) and ground. Also check continuity between yellow wire with tracer and blue wire with tracer. Check harness connections between motor and instrument panel switch. If okay, replace panel switch.

Wiper Motor Quits While Wiping – With engine idling, blower motor on high, operate wipers at high setting for 5 cycles (3 seconds of water and 57 seconds of drying). If motor struggles to a complete stop, clean glass, replace blades, and test circuit breaker in panel switch. As a last resort, replace motor. If motor stopped suddenly in original test, check circuit breaker first.

No Intermittent Wiper (Other Functions Okay) – If blades stop and start erratically, test circuit breaker, wiper switch continuity and continuity of wiring between switch, governor, wiper motor and ground. If operation is intermittent on low speed only, check for loose connections at governor.

Windshield Washer Does Not Operate – Check fluid level, condition of hoses, and for restrictions (particularly ice or dirt in jet opening). Check fuse in panel and for good connection at plug terminal.

WIPER SWITCH TEST

1) Check wiper switch continuity, using a continuity light (J-21008 or equivalent) or an ohmmeter. Continuity should exist at switch positions indicated in Fig. 3.

2) Using an ohmmeter, check variable resistance between No. 4 and 5 terminals of intermittent system if intermittent wipe cycle is not working, but system operates properly on low and high speeds. Turn switch knob counterclockwise as far as possible. Ohmmeter should indicate 5600-8400 ohms. As knob is turned clockwise, resistance should decrease to a minimum of 100-900 ohms.

3) Replace switch if continuity or resistance tests fail. If operation is proper, check wiring.

CIRCUIT BREAKER TEST

Two tests are available for the 7 amp. circuit breaker. Connect wiper switch as shown in Fig. 3, and test as follows:

1) Adjust current draw until it equals circuit breaker rating. Leave switch connected for 10 minutes. Current reading on ammeter should remain at rated current. If circuit breaker opens during 10 minute period, replace switch assembly.

2) Adjust current draw until it is twice the circuit breaker rating (14 amps.). Current reading on ammeter should drop to zero within 15 seconds. If it takes longer, replace switch assembly.

INTERMITTENT GOVERNOR TEST

To check governor requires special electronic testing equipment. However, check all other components in event of unsatisfactory intermittent wiper cycle. If all components function properly, install new governor. The 6-inch governor lead plugs into wiper control switch and shorter 4-inch lead plugs into instrument panel switch.

CURRENT DRAW TEST

1) Remove wiper arms and blades and disconnect motor lead. Connect negative lead of ammeter to positive battery post. See Fig. 3. Connect other ammeter test lead to blue wire with tracer (low speed) of motor harness. Current draw should be approximately 1 amp., but not more than 3 amps.

2) Connect blue wire terminal (high speed). Current draw should remain about the same, but never over 3 amps.

PARK TEST

1) Disconnect motor from harness connection. Temporarily contact a battery feed to either blue or blue with tracer wire to move wiper arms and blades away from normal park position. Insert jumper wire from white to black wire terminals.

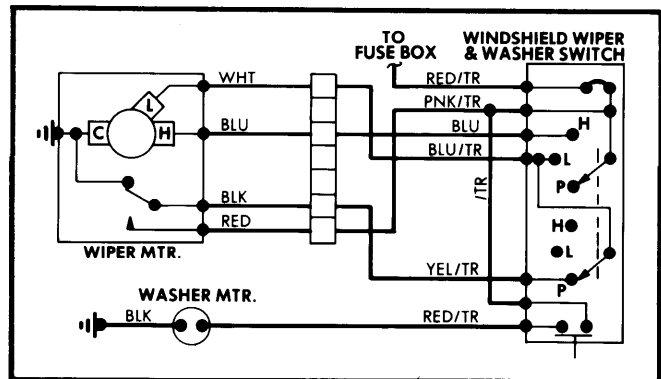

Fig. 4 Jeep 2-Speed Wiper System Wiring Diagram (Cherokee, Wagoneer & "J" Models - Standard)

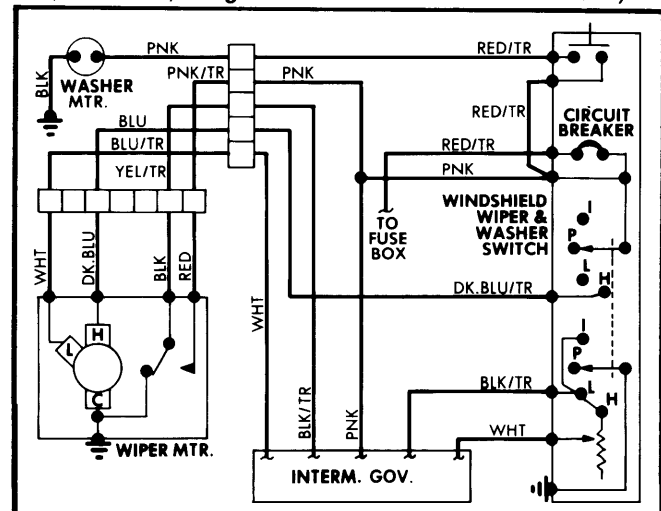

Fig. 5 Jeep 2-Speed Wiper System Wiring Diagram (Cherokee, Wagoneer & "J" Models With Intermittent Governor)

JEEP (Cont.)

2) Contact a battery feed to red wire terminal of motor harness. Motor should operate until wipers have reached normal park position. If not, replace wiper motor.

REMOVAL & INSTALLATION

WIPER MOTOR

"CJ" & Scrambler Models — Remove necessary components from windshield frame. Remove windshield hold-down knobs and fold windshield down. Remove left access hole cover and disconnect drive link from left wiper pivot. Disconnect wiper motor wire harness from switch. Remove attaching screws and wiper motor. To install, reverse removal procedures.

Cherokee, Wagoneer & "J" Models — Remove motor adapter plate-to-dash panel screws. Disconnect wiper wiring harness at motor. Pull motor and linkage out of opening so that drive link-to-crank stud retaining clip can be removed with screwdriver. Remove motor assembly. To install, reverse removal procedure.

OVERHAUL

WIPER MOTOR CHEROKEE, WAGONEER & "J" MODELS ONLY

Disassembly — 1) Using care not to damage ceramic magnets, mark position of drive crank with respect to output shaft. Remove drive crank, mounting bracket, and ground strap. Remove gear housing cover and gasket, idler gear and pinion, motor through bolts and motor housing. Remove end play spring, output gear and shaft, switch lever, washer and seal from gear housing.

2) Disassemble brushes, harness and springs from end head (terminal board). Remove end head assembly, parking lever pin, and all old lubricant. Inspect gear housing and all components, replacing parts as necessary. Lubricate all bearing surfaces and gears.

Reassembly — 1) Install switch washer and lever in gear housing with cam rider pointing toward output shaft hole. Install seal and output gear and shaft in gear housing. Be sure switch lever is clear of cam and gear assembly. Place idler gear and

pinion on shaft and insert shaft through switch lever and washer into gear housing. Maintain .001-.007" clearance between push nut and gear.

2) Install end spring, parking lever pin, and attach brush terminals and switch terminals to end head. Attach end head to gear housing. Install springs and brushes in end head. Lightly lubricate armature end shaft and ball. Install armature in gear housing. Plastic thrust button in end play spring should bear against end of armature shaft.

3) Install motor housing over armature. Align motor housing and gear housing marks and install through bolts. Lubricate gear housing cavity generously, and install gasket and cover on gear housing. Attach ground strap and mounting bracket. Install grommets in mounting bracket and secure motor assembly to bracket. Install plain washer and spring washer on output shaft, and position drive crank on output shaft in previously marked position. Tighten nut to 10 ft. lbs.

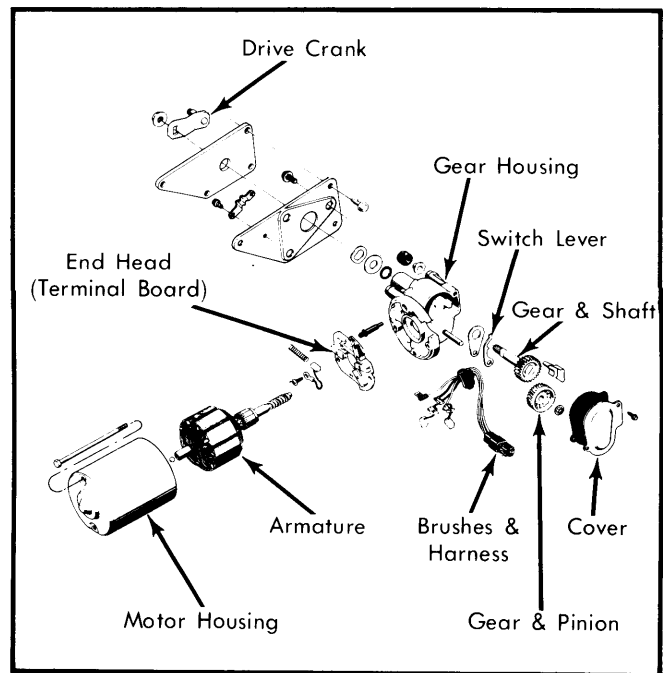

Fig. 6 Exploded View of Wiper Motor Assembly (Cherokee, Wagoneer & "J" Models)