

GENERAL MOTORS – INTEGRAL WIPER/WASHER MOTOR

All Exc. "P" Models

NOTE – For "P" Model applications, see "General Motors – Square Motor" article in this section.

DESCRIPTION

Two speed motor, permanent magnet type, consists of partsfield magnets, armature and drive gear within upper and lower housings. The washer pump is assembled on the outside surface of the upper half of the housing and is an integral part of the wiper motor assembly. Wiper motor is protected by an automatic reset circuit breaker. Vehicle wiring is protected by fuse in fuse block.

OPERATION

The basic washer pump is a spring loaded piston enclosed in a plastic cylinder housing with an actuator plate extending from the cylinder housing. A valve assembly, consisting of two exhaust and one intake check valve, is attached to the end of the cylinder housing. A tang on the piston actuator plate holds the plate in a lock-out position, (no pumping action). To start the pump, push washer button which will energize the relay. This pulls the relay armature toward the coil allowing the ratchet gear pawl to engage the ratchet gear and begin rotation. This sequence starts pumping action.

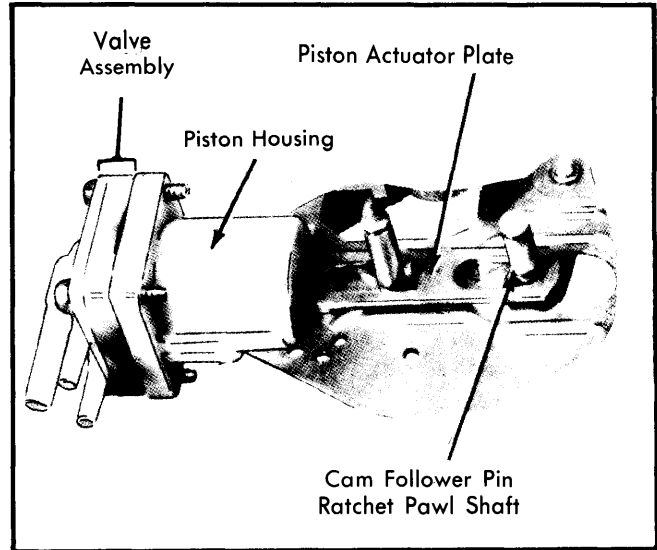

Fig. 2 Washer Actuator Plate and Valve Assembly

TROUBLE SHOOTING

Wiper Inoperative – Check fuse, wiring harness, wiper ground and dash connections.

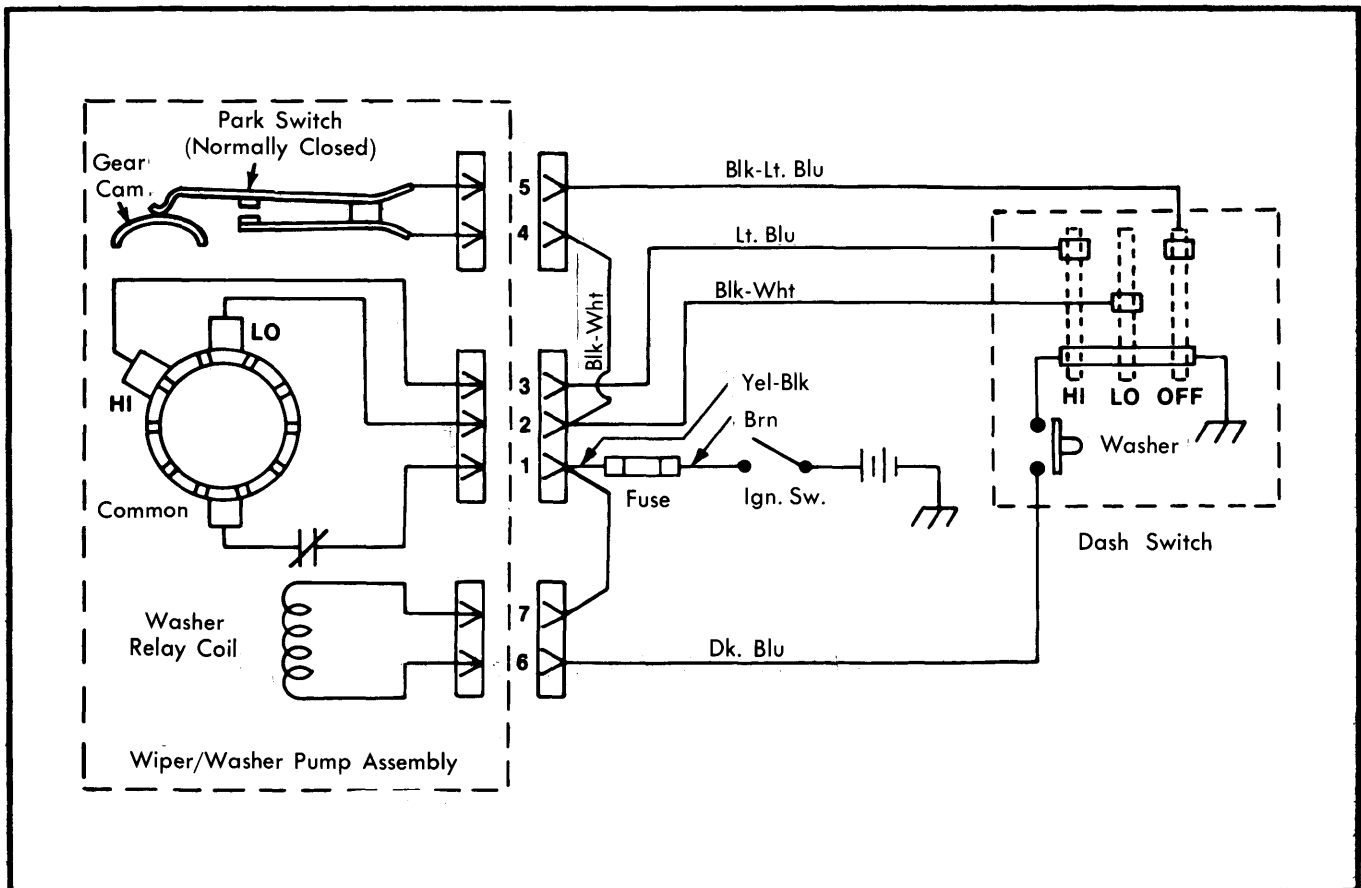

Fig. 1 General Motors Truck Wiper Motor and Integral Washer System Wiring Diagram

Wiper/Washer Systems

GENERAL MOTORS – INTEGRAL WIPER/WASHER MOTOR (Cont.)

Wiper Will Operate One Speed Only – Check for open wiring between terminals 2 or 3 and the dash switch. Check dash switch and if not operable, check "Low" and "High" brush leads.

Wiper Blades Will Not Return To Park – Check for open wire from terminal 5 to dash switch. If not open, dash switch or wiper park switch needs replacing.

Wiper Will Not Shut Off – Disconnect wiring from terminals 4 and 5. Replace park switch assembly if motor stops. If motor still runs, remove wires from terminals 1, 2 and 3. Connect a 12 volt lead to terminal 1 only and if motor does not run it indicates a ground in wires from wiper motor to terminal 2 or 3 at dash switch. If it runs, check for internal ground in high or low brushes.

Washer Pump Will Not Run – Turn ignition switch to "ON" position. Insure washer solution is adequate, then push wash button and listen for relay to energize. With ignition still "ON" and wiring connected to wiper terminals, connect test lamp lead to ground and probe terminals 6 and 7.

- Light "OFF" at both terminals; check for open in circuit to the pump.
- Light "ON" at one terminal, replace coil-park switch assembly.
- Light "ON" at both terminals, but one light is dim; ground the dim light terminals. If pump runs, check for open in wire between pump and dash switch or for a defective dash switch.

NOTE – Delay wiper system is available as optional equipment. A separate control assembly is utilized which provides a variable delay of 1 to 20 seconds.

REMOVAL & INSTALLATION

WIPER MOTOR (EXC. "G" MODELS)

Removal & Installation – Ensure wiper motor is in park position, then disconnect ground cable from battery, electrical harness at motor and hoses at washer pump. Reach through access hole in cowl grille and loosen wiper drive rod attaching screws. Remove drive rod from wiper motor crank arm. Remove wiper motor-to-dash panel attaching screws and remove motor assembly. To install, reverse removal procedure while noting the following: Lubricate crank arm pivot prior to reinstallation.

WIPER MOTOR ("G" MODELS ONLY)

Removal – Ensure wiper motor is in park position, then disconnect battery ground cable and remove wiper arms. Remove cowl panel cover. Loosen nuts holding linkage to crank arm and lift linkage off arm. Disconnect wiring to motor. Remove left dash defroster outlet from flex hose and position hose to one side. Remove screw securing left hand heater duct to engine cover shroud and slip heater duct down and out. Remove washer hoses, then remove screws securing wiper motor to cowl and lift wiper motor from under dash.

Installation – To install, reverse removal procedures while noting the following: Ensure wiper motor is in park position before installing. Lube wiper motor crank arm pivot prior to installation.

OVERHAUL

Repairs to motor/gear box section of the wiper assembly are limited to the switch, armature, cap and brush holder assembly plus the external parts, crankarm, spacer/seal (plastic) and output shaft seal.

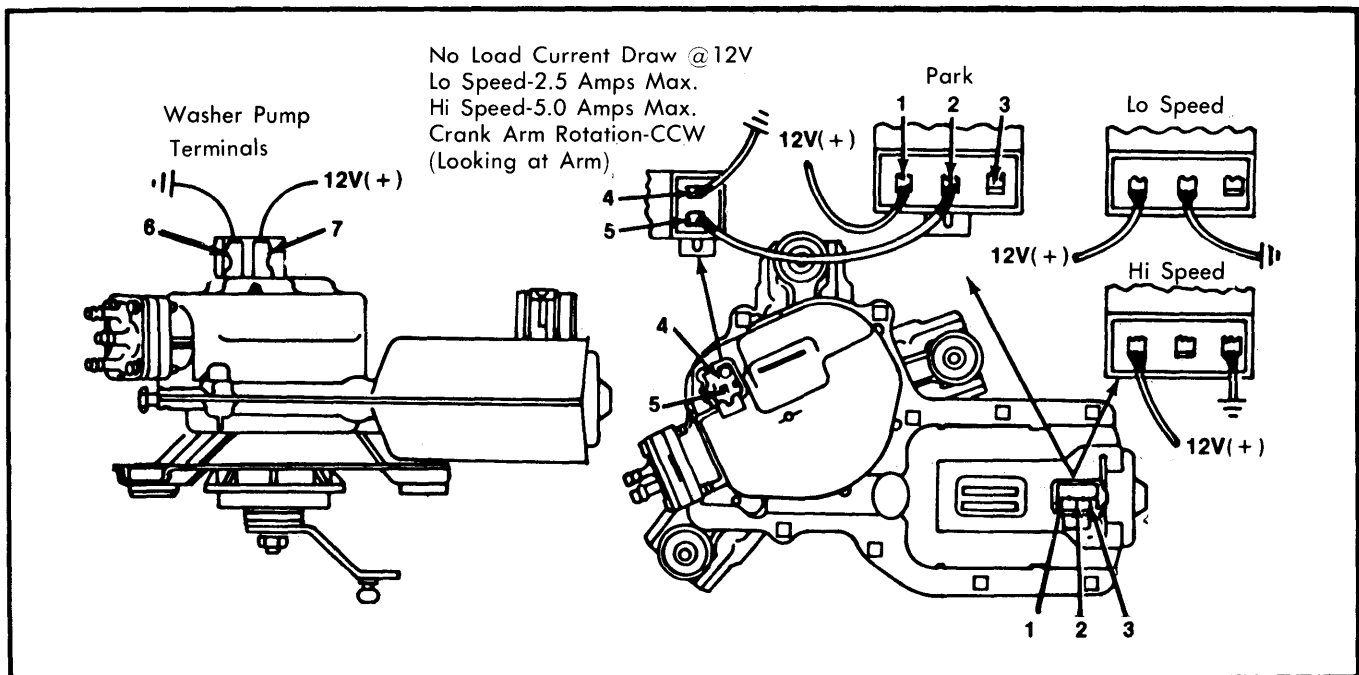

Fig. 3 Wiper/Washer Motor Terminal Check Diagram