

FORD

All Models

DESCRIPTION

Two speed permanent magnet windshield wiper motor is used. The two speed motor uses a three brush plate and switch assembly. When control selector is in low position, grounded brush and white wire brush are used to operate motor at low speed. When control selector is in high position, grounded brush and blue wire brush are used to operate motor at high speed. When control selector is moved to park position, motor will continue at low speed until park switch lower contacts open, stopping motor in park position. Optional interval wipers are available on "E" models, "F" models and Bronco. Intermittent operation is controlled by a variable resistor in the windshield wiper control switch, combined with the electronic governor allows a variable pause between wiping cycles.

For normal operation on "F" models, turn wiper control knob to right for low or high speed. For intermittent operation, rotate wiper control knob to left. The more knob is rotated to left, the greater the time interval between wiper blade sweeps. On "E" models the wiper switch knob slides toward the right with the first position being intermittent, the second is low and the third is high. As the control is moved to the left of intermittent position the interval between blade sweeps is at a maximum and as it moves to the right of intermittent detent, the blade sweep interval is reduced.

The electric windshield washer system consists of an instrument panel control switch integral with the wiper control switch, a reservoir and motor assembly, nozzles and connecting hoses.

TESTING

WIPER MOTOR CURRENT DRAW

"E" Models - Disconnect linkage from motor and use suitable connector sleeves (kit no. C4AZ-14294-B or equivalent) between motor terminals and a volt-amp meter. Connect positive (red) lead from meter to center terminal on motor end plate

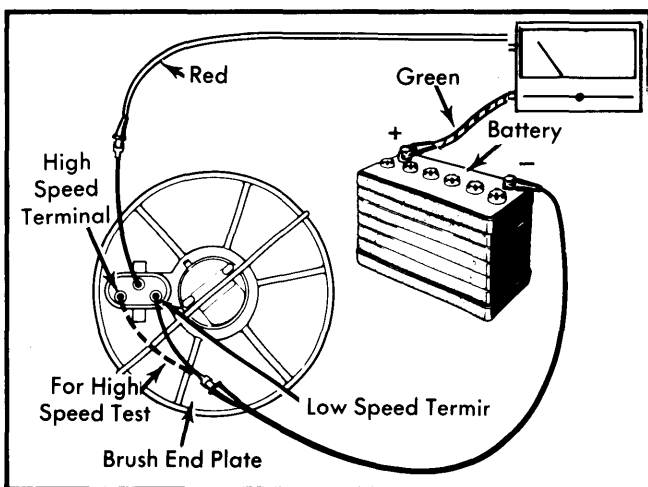

Fig. 1 Motor Current Draw Test "E" Models

and green lead from meter to battery positive post. Connect a jumper wire from negative post of battery to low speed terminal on motor end plate and check current draw. Move jumper wire from low speed to high speed terminal and check current draw. Current draw should not exceed 3.5 amperes. If current draw is excessive, check output arm and windlatch mechanism for binding or damage before replacing motor. See Fig. 1.

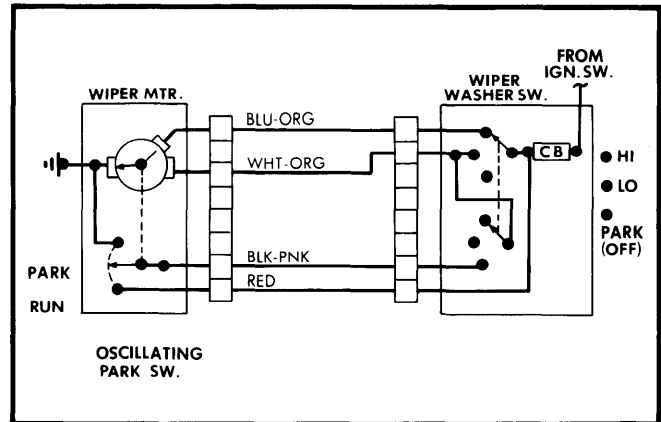

Fig. 2 Wiring Diagram 2-Speed Non-Interval "F" Series and Bronco

Bronco and "F" Models - Disconnect linkage from motor and disconnect electrical plug from motor. Connect green lead from a volt-amp meter to battery positive post and positive (red) lead from meter to low speed connection at plug. Check current draw. Move positive (red) lead from meter to high speed connection at plug and check current draw. Current draw should not exceed 3.0 amperes at either connection. See Fig. 3.

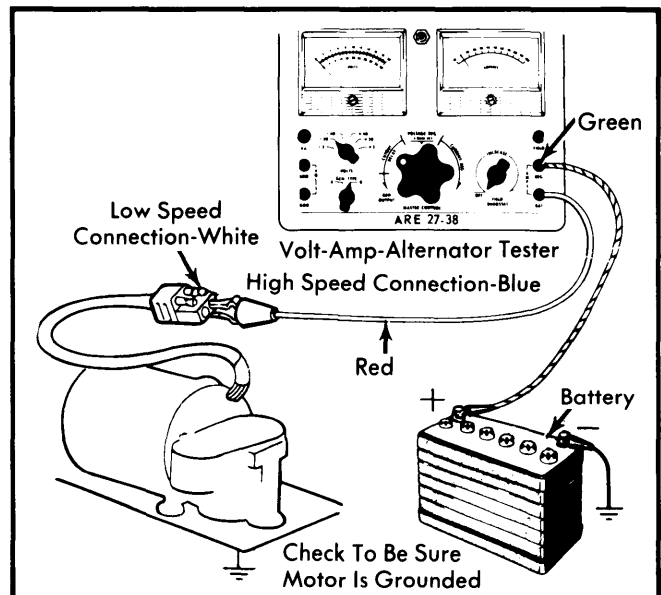

Fig. 3 Motor Current Draw Test Bronco and "F" Models

FORD (Cont.)

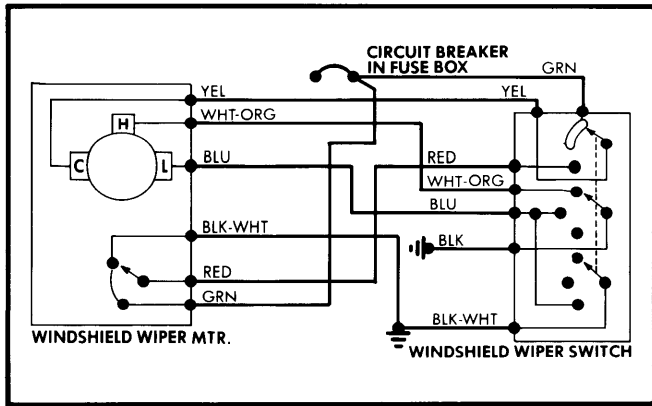

Fig. 4 Wiring Diagram 2-Speed Non-Interval "E" Models

CIRCUIT BREAKER

Circuit breaker is located in wiper control switch on all rotary switches and in fuse panel for slide wiper control switches. On models with the circuit breaker located in the fuse panel, the rating is 7.5 amps. The circuit breaker integral with the switch is rated at 7 amps. The following test does not apply to vehicles with the circuit breaker located in the fuse panel. See Fig. 5.

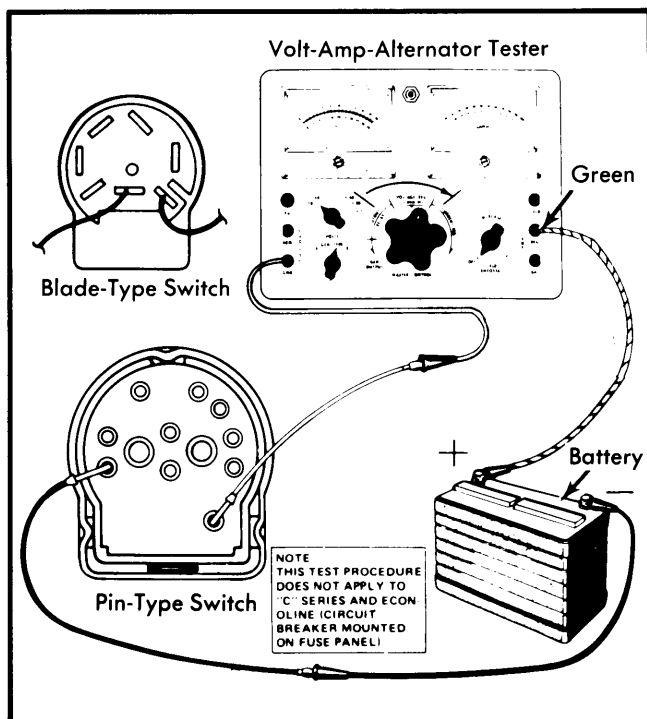

Fig. 5 Circuit Breaker Test

1) Before connecting tester leads as shown in illustration, short tester leads together and adjust current draw until it equals circuit breaker rating. Connect switch to tester and leave switch connected for ten minutes. Current reading should remain at rated current. If circuit breaker opens during the ten minutes, replace wiper switch assembly.

2) Short tester leads together and adjust current draw until it is twice rated current. Connect switch to tester and current reading on ammeter should drop to zero within 20 seconds. If it takes longer than 20 seconds for breaker to open, replace wiper switch assembly.

WIPER SWITCH CONTINUITY TEST

Check continuity between switch terminals as shown in illustrations. Either a self powered test light or an ohmmeter can be used to test a standard two speed switch. An ohmmeter must be used to test a switch with the intermittent system. To detect marginal operation of switch, rotate knob or slide switch while each reading is being taken. If switch does not exhibit continuity as shown or poor continuity exists, replace switch.

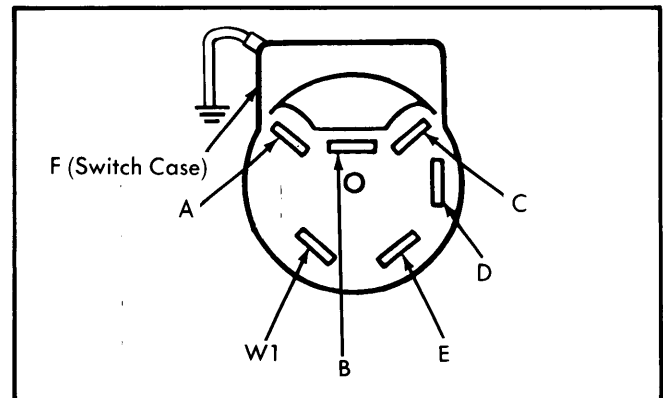

Fig. 6 Blade Type Switch Connector Non-Interval

Switch Position	Terminals
Off (Park)	C-D, A-B
Low	A-B-C
High	A-B-E
Wash	A-B-W1

Intermittent Switch Position	Intermittent Terminals
Off (Park)	A-B, D-E
Low	A-B, D-E-F
High	D-E-F, A-B-C
Intermittent	⓪E-F, A-B
Wash	A-B-W1

⓪ - Variable resistance between terminals D-E should be minimum 200-1000 ohms and maximum 5600-8400 ohms.

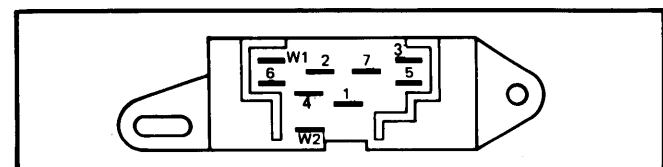

Fig. 7 Blade Type (Slide Switch) Connector Non-Interval

Wiper/Washer Systems

FORD (Cont.)

Switch Position (Non-Interval)

Switch Position (Non-Interval)	Terminals
Off (Park)	1-5,3-7
Low	1-4,2-7
High	1-4,2-6
Wash	W1-W2

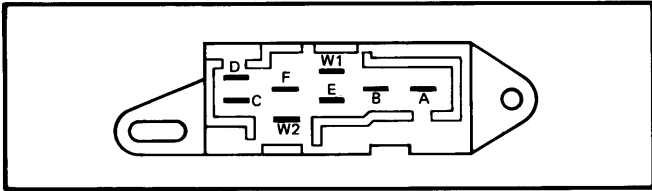

Fig. 8 Blade Type (Slide Switch) Connector Interval

Switch Position (Interval)

Switch Position (Interval)	Terminals
Off (Park)	A-E
Low	B-E-F-C
High	D-B-F-C
Intermittent	B-E-F
Wash	W1-W2

NOTE — Resistance between terminals F-C will vary 500 ± 400 ohms at minimum dwell to $10,000 \pm 2000$ at maximum dwell.

INTERMITTENT GOVERNOR

If intermittent operation is unsatisfactory, check motor current draw, then check control switch and all connecting wires for continuity. If motor, switch and connecting wires are satisfactory, replace electronic governor assembly.

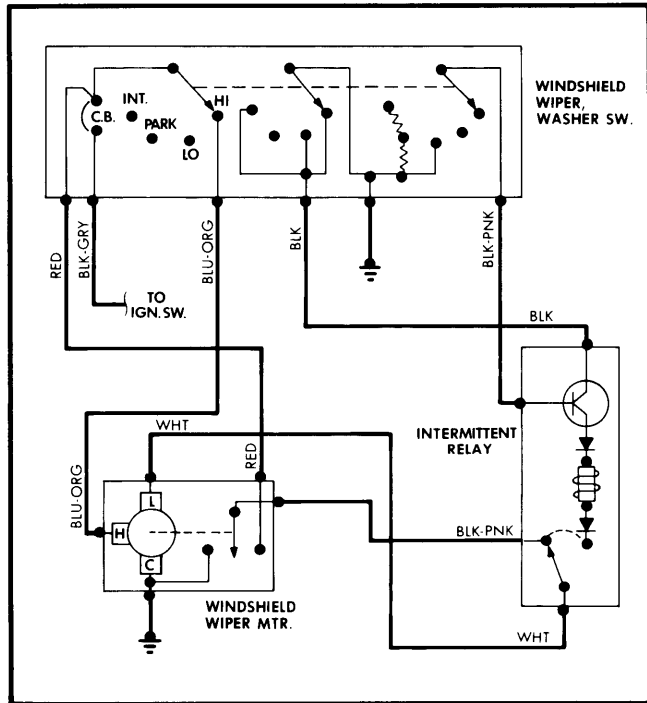

Fig. 9 Wiring Diagram 2-Speed Interval Bronco and "F" Models

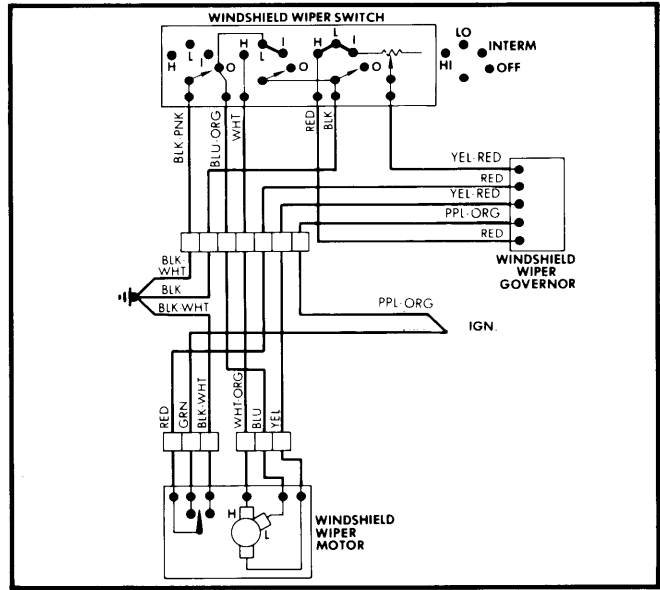

Fig. 10 Wiring Diagram 2-Speed Interval (Depressed Park) "E" Models

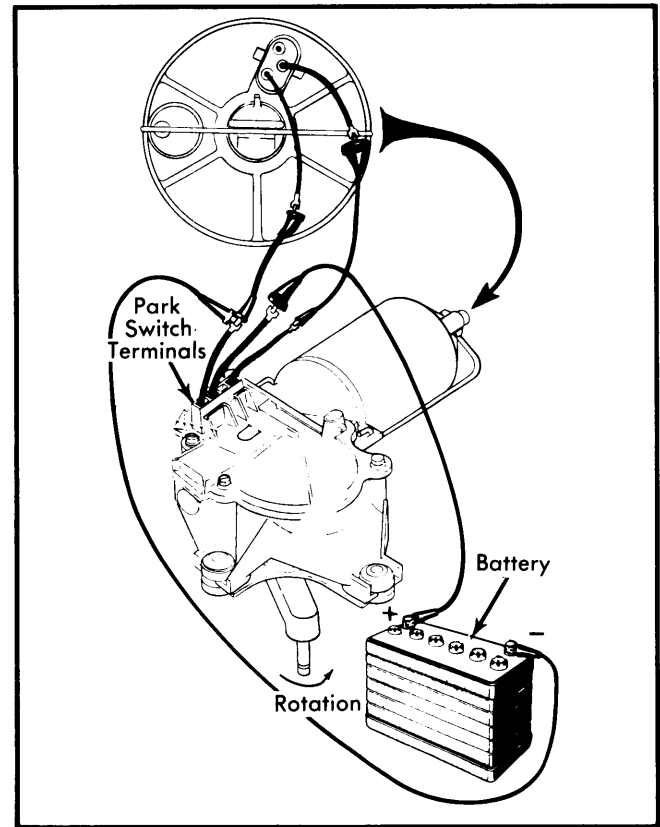

Fig. 11 Motor Park Test "E" Models

WASHER PUMP CURRENT DRAW

Connect test leads of ammeter as shown in Fig. 12. The current draw should not exceed 4 amps., or be less than 1.7 amps., while the washer pump is pumping fluid.

FORD (Cont.)

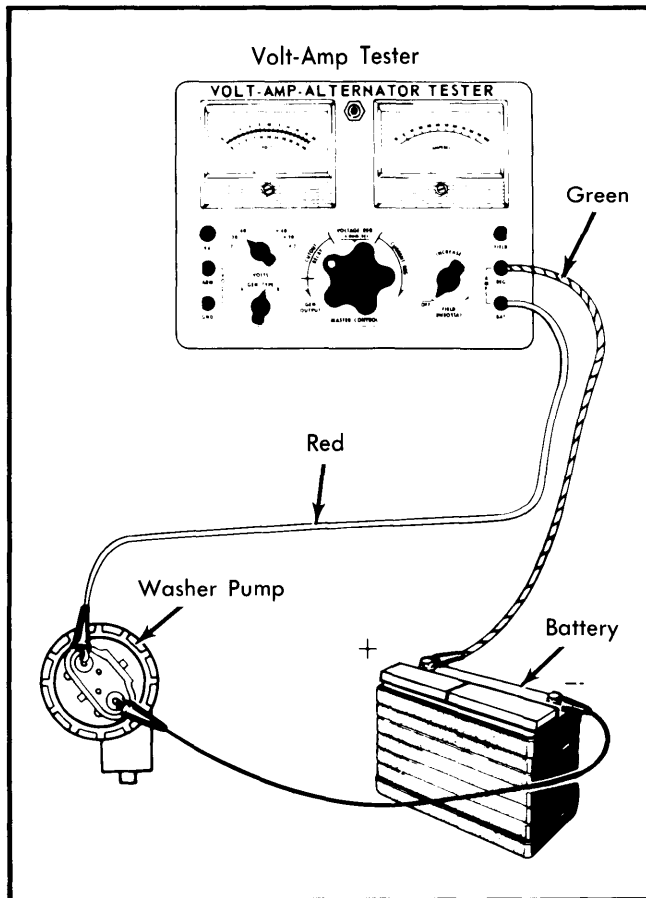

Fig. 12 Washer Pump Current Draw Test

REMOVAL & INSTALLATION

WIPER MOTOR

"E" Models — Disconnect battery ground cable, remove fuse panel and bracket assembly. Then disconnect wires at motor brush cap and gear box cover. Remove wiper arm blade assemblies from pivot shaft, outer air inlet cowl and clip retaining motor drive arm to linkage mounting arm and pivot shaft assembly. Remove motor attaching bolts and remove motor from vehicle. To install, reverse removal procedures while noting the following: If a new motor is installed, motor must be in park position.

Bronco & "F" Models — 1) Disconnect negative battery cable. Remove wiper arms and blade assemblies. Remove cowl grille attaching screws and raise cowl. Disconnect washer nozzle hose and remove cowl grille.

2) Remove wiper linkage clips from motor output arm. Disconnect motor wiring connector. Remove motor attaching screws and remove motor. To install, reverse removal procedure.

WIPER CONTROL SWITCH

"E" Models — Disconnect battery ground cable and remove windshield wiper switch knob. Remove ignition switch bezel.

Depress button on top of headlight switch and pull knob and shaft from switch. Remove screws at bottom of finish panel and pry two upper retainers away from instrument panel assembly. Disconnect connector from wiper switch, remove switch attaching bolts and remove switch from vehicle. To install, reverse removal procedures.

Bronco and "F" Models — Disconnect battery ground cable and remove wiper switch knob, bezel nut and bezel. Pull switch out from under instrument panel and disconnect plug connector from switch. Remove switch from vehicle. To install, reverse removal procedure.

INTERMITTENT GOVERNOR

"E" and "F" Models — Governor is mounted on lower flange of instrument panel. Disconnect wire connectors from governor, remove attaching screws and remove governor. To install, reverse removal procedure.

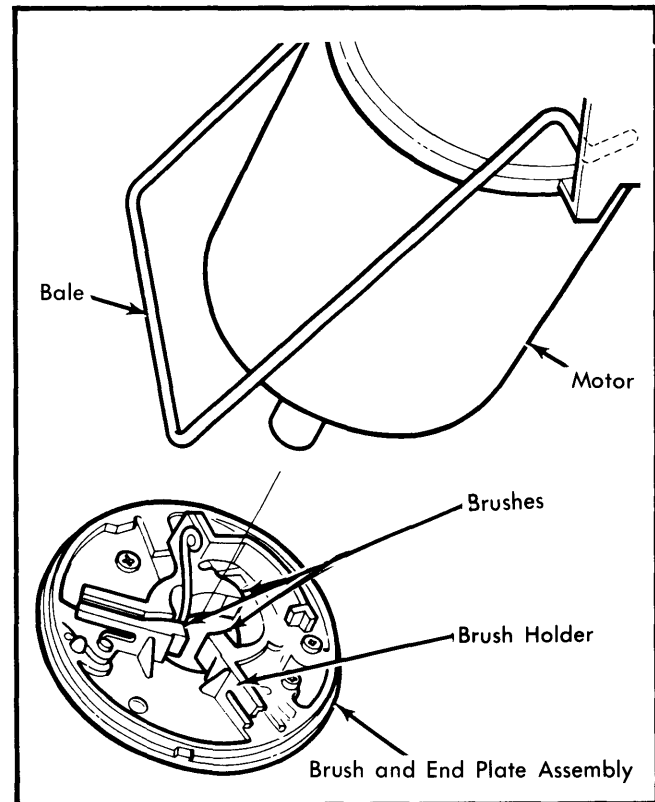

Fig. 13 Motor Brush End Plate Assembly, "E" Models

WASHER PUMP & RESERVOIR

1) Disconnect lock tab wire connector using a small screwdriver. Remove hose and drain reservoir. Remove retaining screws and lift motor from vehicle.

2) With reservoir drained, remove reservoir attaching screw and remove reservoir. To install, reverse removal procedure, noting that reservoir must be filled before connecting electrical connections or operating pump.

Wiper/Washer Systems

FORD (Cont.)

OVERHAUL

WIPER MOTOR

NOTE — The wiper motor for "F" and Bronco models is not serviceable. It must be replaced as a complete assembly. Wiper motor for "E" models is serviceable only in kits of major sub-assemblies. The kits available are for the cover and switch assembly and the brush end plate.

COVER & SWITCH ASSEMBLY

Remove four cover retaining screws and remove assembly. Replace with appropriate kit. Be sure that ground strap is under the cover screw. Tighten screws to 15-25 INCH lbs.

BRUSH END PLATE

NOTE — "E" model switch assembly is identified by the letter "U" stamped on the outside surface.

Observe position of bale retainer and pry it off with a screwdriver. Remove end plate and plug. Replace with appropriate kit. When installing new kit, use a fine wire probe through the hub opening to position the brushes on the commutator. Rotate end plate to position key in notch and assemble plug. Do not overbend bale retainer when reinstalling.

WASHER MOTOR, SEAL & IMPELLOR

1) With reservoir assembly removed from vehicle, pry out retaining ring with small blade screwdriver. Using pliers, grip one wall around the electrical terminal and pull out the motor, seal and impellor assembly.

2) Before installing new assembly, make sure reservoir chamber is free of foreign matter. Lubricate outside of seal with powdered graphite before installation. Align small projection on motor end cap with slot in reservoir so seal seats against bottom of motor cavity. Reverse disassembly procedures for remaining components.